

PERIPHERAL COMPONENTS INDEX

GLOBAL STANDARD COMPONENTS

TM

NAAMS



Assembly

04/15/20

PAGE	DATE	NAAMS CODE	DESCRIPTION
R-1	04/15/20		Peripheral Components Index
R-2	04/12/05		Stairs and Railings
R-3	04/15/20	ALV100 - 500	Vertical Light Screen Assembly
R-4	08/23/13	ALV110	Base Plate
R-5	02/06/08	ALV120	Swivel Base Plate
R-6	12/02/19	ALV130 - 131	Stand Sleeve
R-7	06/11/08	ALV130 - 131	Stand Sleeve (Plate Detail)
R-8	12/02/19	ALV140	Shaft Sleeve
R-9	02/06/08	ALV150	Cover Spacer
R-10	02/06/08	ALV160	Cover Spacer
R-11	02/06/08	ALV170 - 570	Shaft
R-12	04/15/20	ALV180 - 580	Cover
R-13	02/02/12	ALH100 - 500	Horizontal Light Screen Assembly
R-14	02/06/08	ALH110	Base Plate
R-15	02/06/08	ALH120	Stand Sleeve (R.H.)
R-16	02/06/08	ALH130	Stand Sleeve (L.H.)
R-17	10/29/08	APB001	Palm Button Stand Base
R-18	10/29/08	APB002	Palm Button Stand Extension
R-19	04/30/09	ATD060 - 180	Tip Dresser Stand
R-20	11/12/12	ADN001	Devise Net Mounting Bracket

STAIRS AND RAILINGS

The automotive industry follows the specifications for stairs and railings that have been issued by the Occupational Safety and Health Administration (OSHA). You may access the required OSHA website by clicking on the relevant hyperlink below.

Railings (Guarding floor and wall openings and holes. - 1910.23)

http://www.osha.gov/pls/oshaweb/owadisp.show_document?p_table=STANDARDS&p_id=9715

Stairs (Fixed Industrial Stairs. - 29CFR)

http://www.osha.gov/pls/oshaweb/owadisp.show_document?p_table=STANDARDS&p_id=9716

VERTICAL LIGHT SCREEN ASSEMBLY

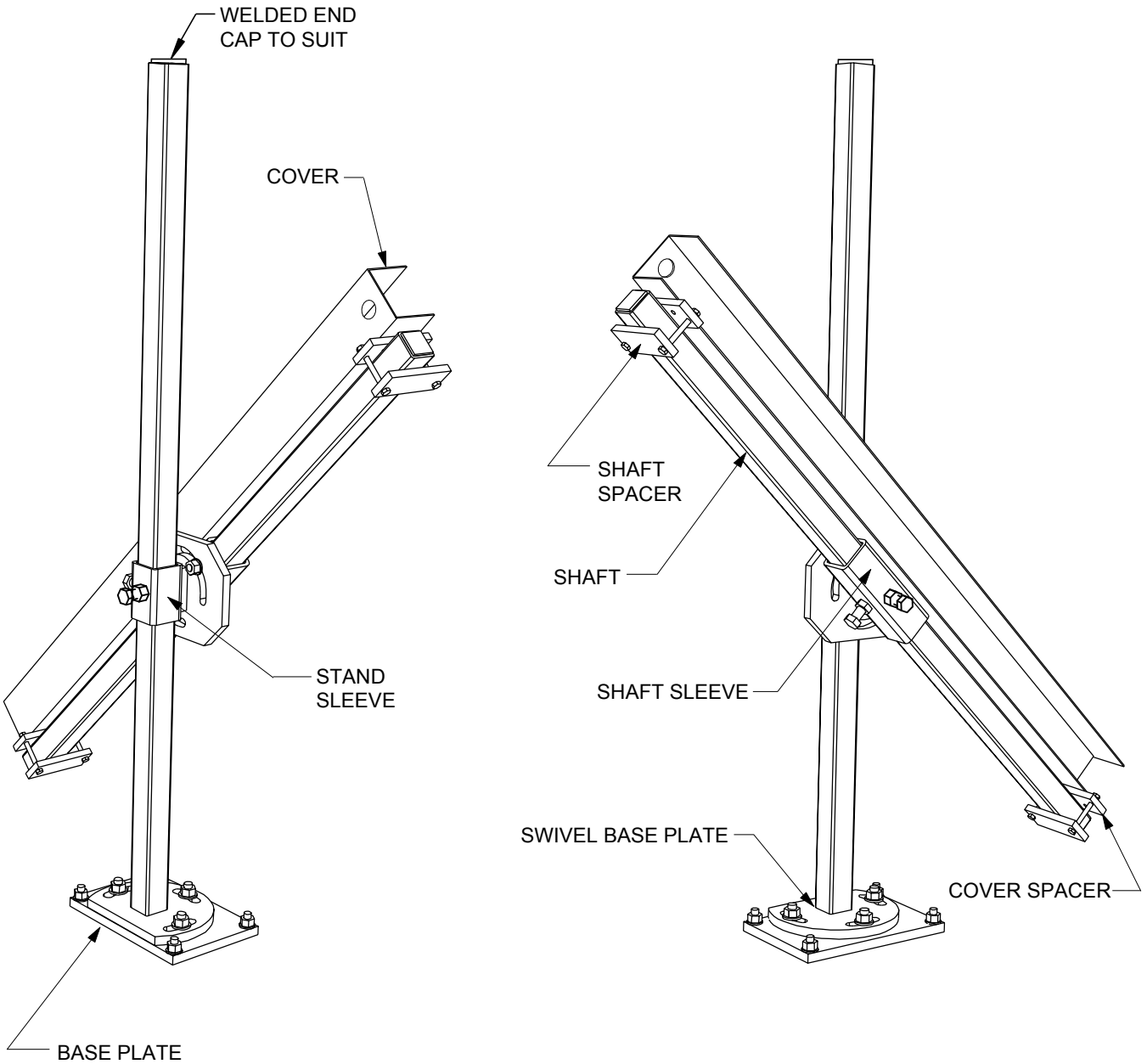

Adjustments may be tack welded after final set-up.

ASSEMBLY		BASE PLATE	SWIVEL BASE PLATE	STAND SLEEVE		SHAFT SLEEVE	COVER SPACER	SHAFT SPACER	SHAFT	COVER
SHOWN	OPPOSITE			SHOWN	OPPOSITE					
ALV100	ALV101	ALV110	ALV120	ALV130	ALV131	ALV140	ALV150 (2 Req.)	ALV160 (2 Req.)	ALV170	ALV180
ALV200	ALV201								ALV270	ALV280
ALV300	ALV301								ALV370	ALV380
ALV400	ALV401								ALV470	ALV480
ALV500	ALV501								ALV570	ALV580

C

E

D

A

B

BASE PLATE ALV110

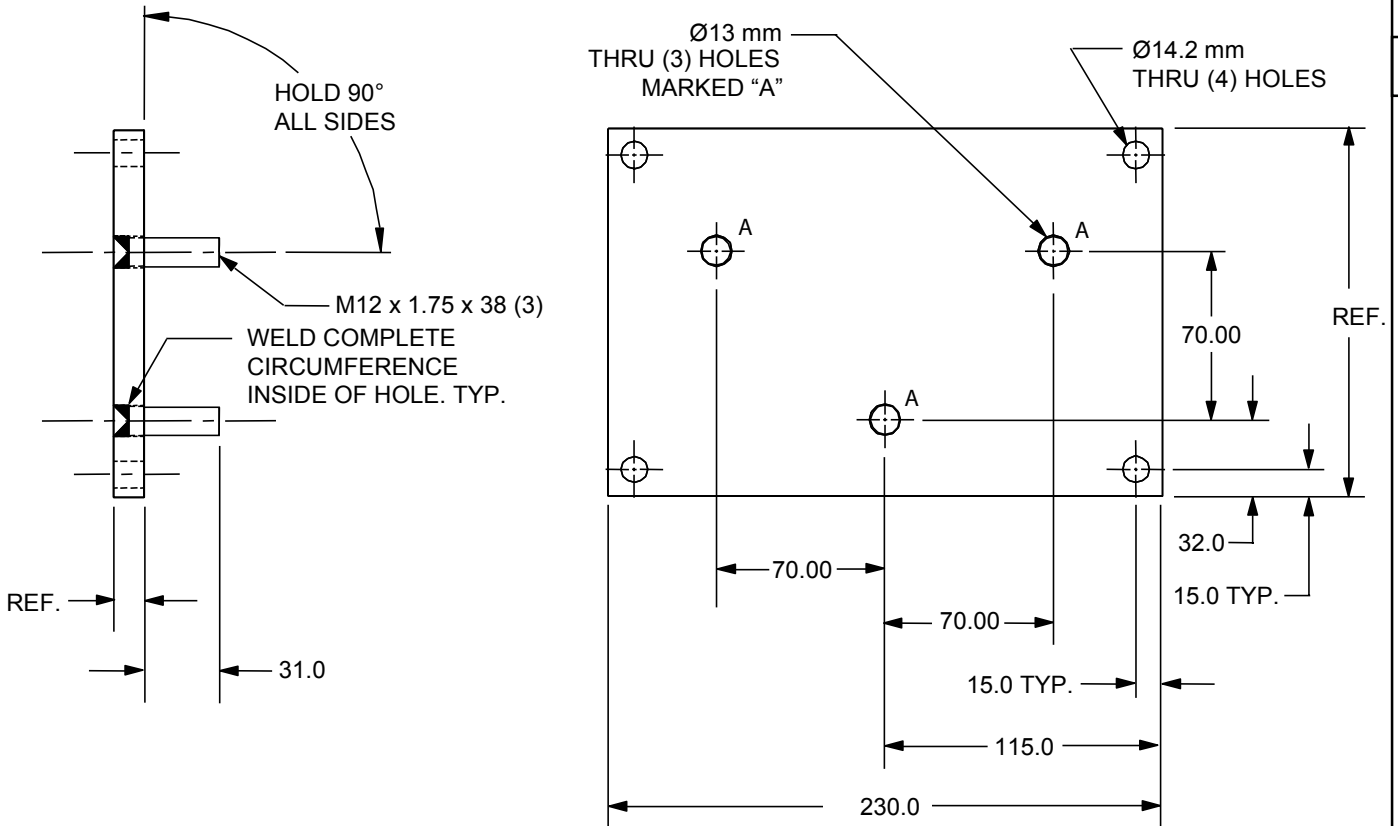

B

A

INCH STOCK
 STL PLT ASTM A-36 1/2" X 6" X 230mm

METRIC STOCK
 STL PLT ASTM A-36 12 X 150 X 230

SEE PAGE B-1.1 FOR GLOBAL MATERIALS CHART

SWIVEL BASE PLATE ALV120

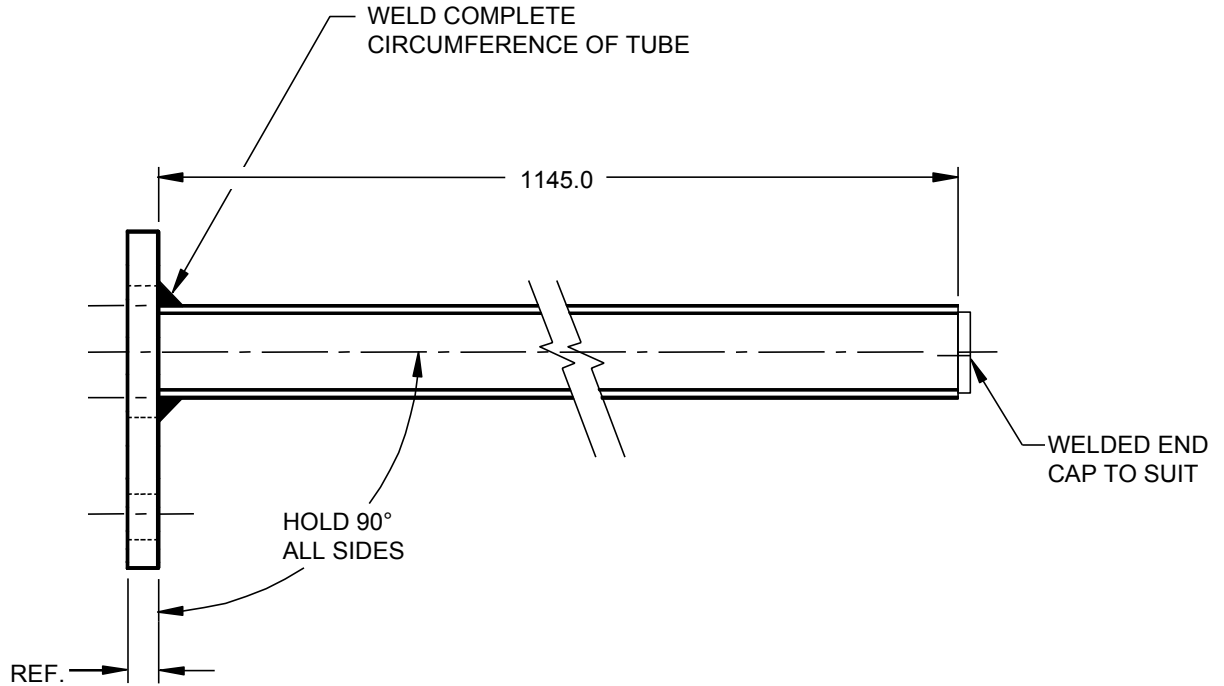

A

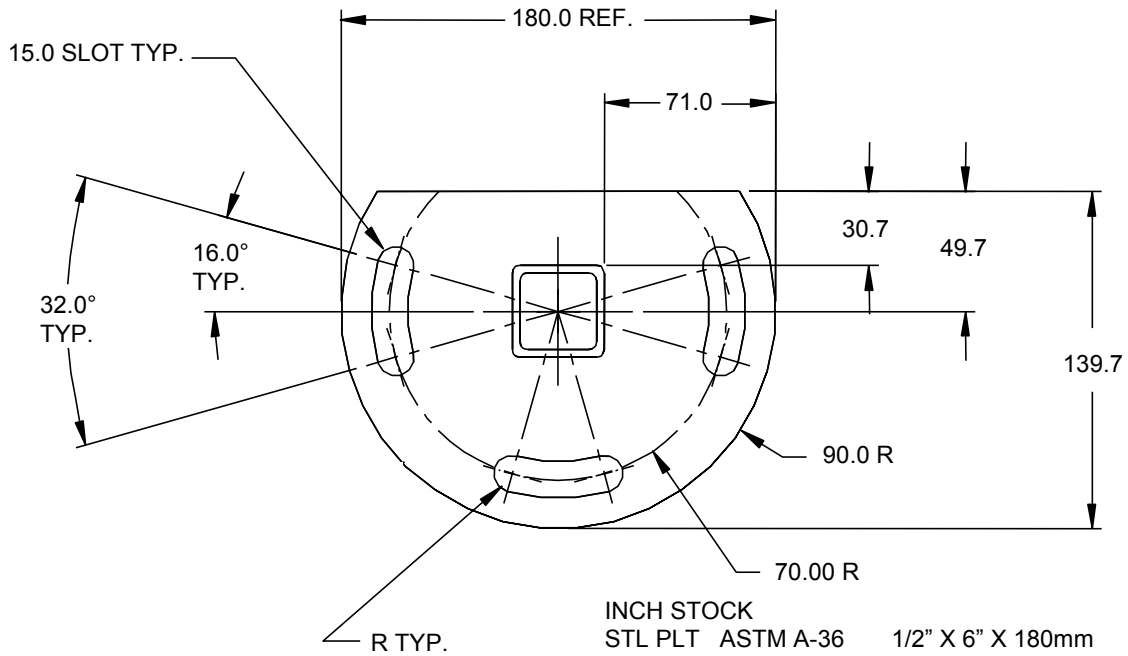

INCH STOCK		
STL PLT	ASTM A-36	1/2" X 6" X 180mm
STL TUBG	ASTM A-36	1 1/2" X 1 1/2" X 1/4" X 1145mm
METRIC STOCK		
STL PLT	ASTM A-36	12 X 150 X 180
STL TUBG	ASTM A-36	40 X 40 X 5 X 1145

SEE PAGE B-1.1 FOR GLOBAL MATERIALS CHART

B

STAND SLEEVE ALV130 - ALV131

ALV130 SHOWN
 ALV131 OPPOSITE

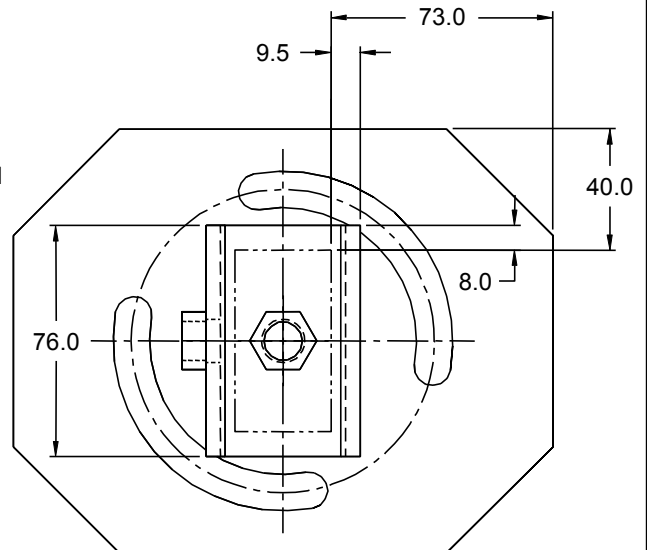
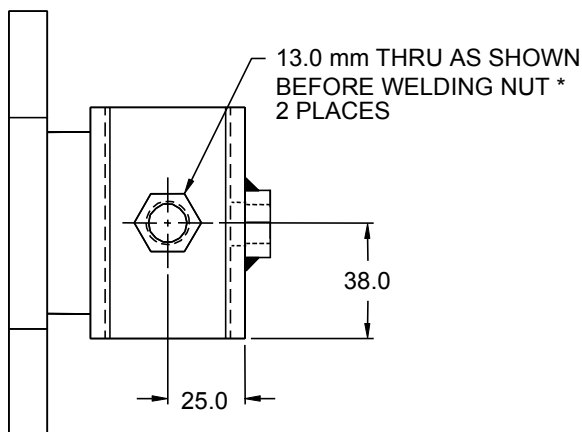
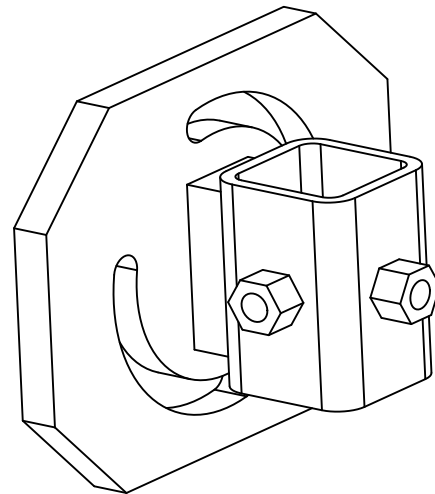
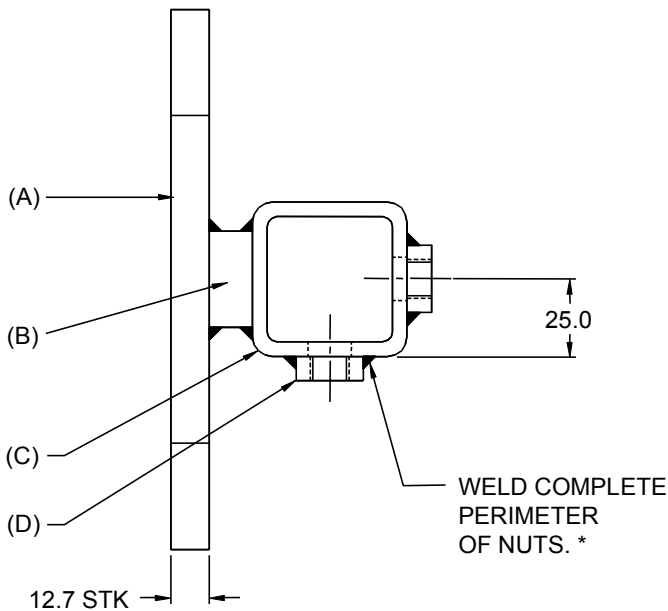

INCH STOCK

- (A) 1 - STL PLT ASTM A-36 1/2" X 7" X 140.0mm
- (B) 1 - STL PLT ASTM A-36 5/8" X 1 1/4" X 60.0mm
- (C) 1 - STL TUBG ASTM A-36 2" X 2" X 3/16" X 76.0mm
- (D) 2 - F421218 HEX NUT

METRIC STOCK

- (A) 1 - STL PLT ASTM A-36 12 X 140.0 X 178.0
- (B) 1 - STL PLT ASTM A-36 15 X 30 X 60.0
- (C) 1 - STL TUBG ASTM A-36 50 X 50 X 4 X 76.0
- (D) 2 - F421218 HEX NUT

SEE PAGE B-1.1 FOR GLOBAL MATERIALS CHART

* LOCATE HOLE, NUT & WELD SEAM ON SAME SIDE OF TUBING

SEE NEXT PAGE FOR PLATE DETAIL

STAND SLEEVE (PLATE DETAIL) ALV130 - ALV131

A
C
D
E
B
F

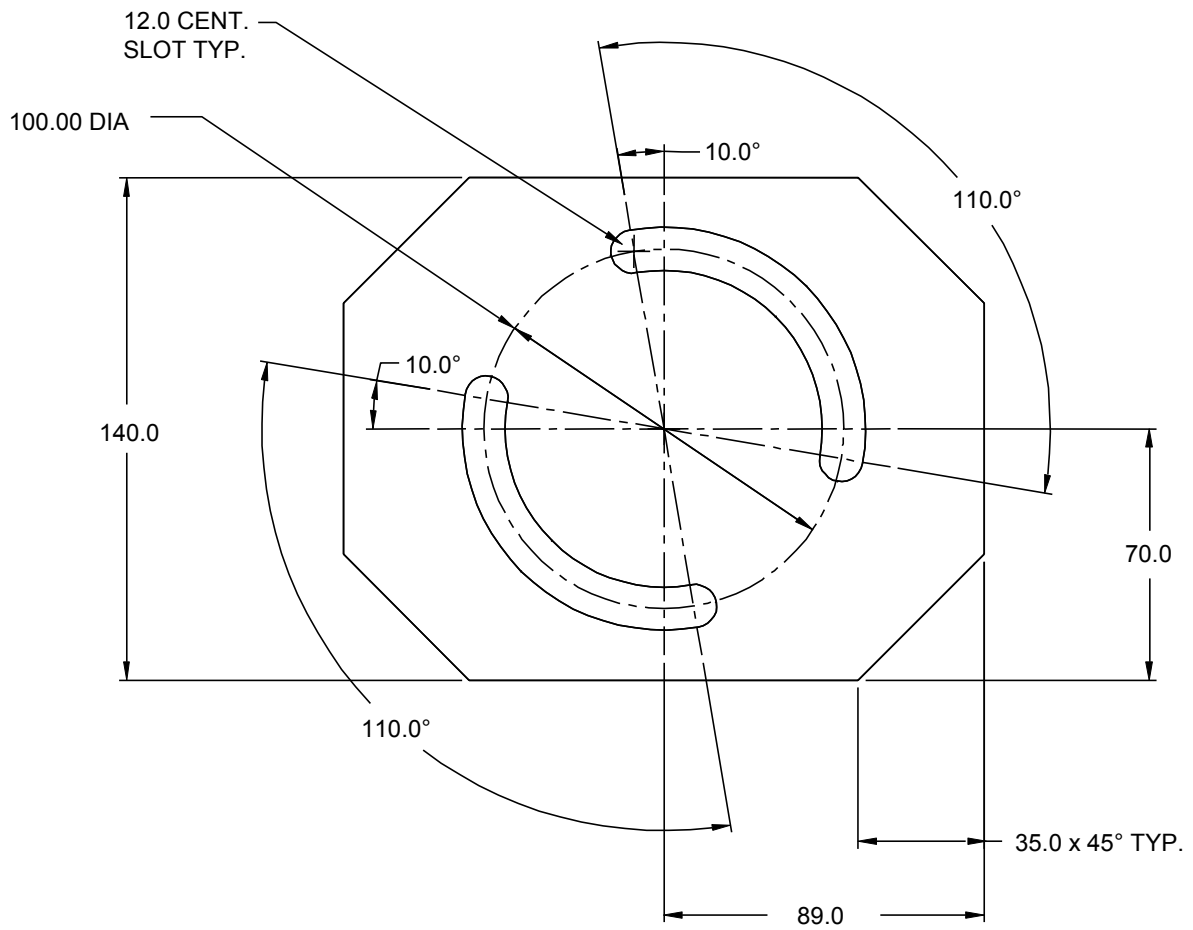

ITEM A ON PRECEEDING PAGE

SHAFT SLEEVE ALV140

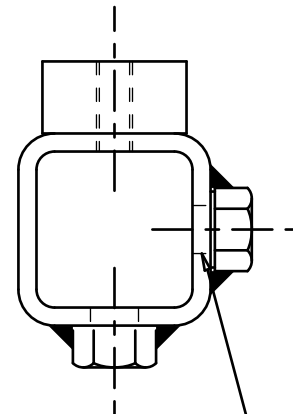
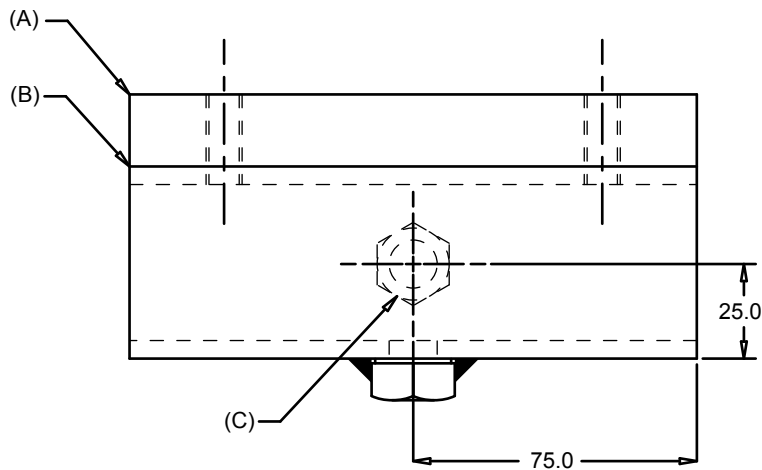
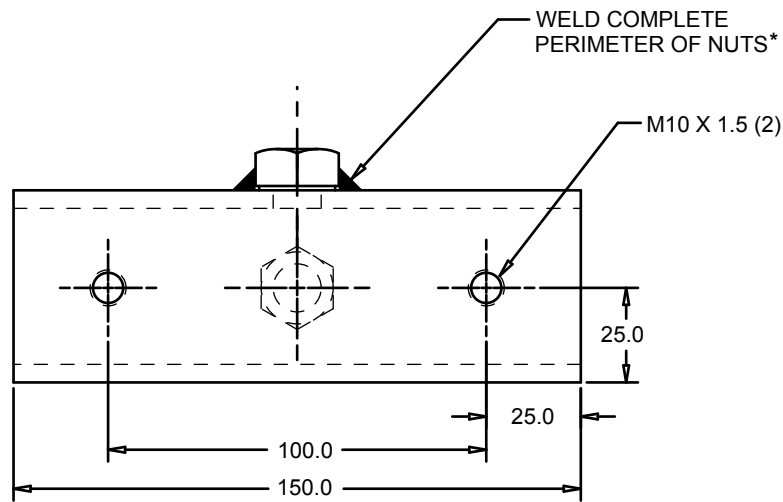

A
D

B

C

INCH STOCK

- (A) 1 - STL PLT ASTM A-36 3/4" X 1 1/2" X 150mm
- (B) 1 - STL TUBG ASTM A-36 2" X 2" X 3/16" X 150mm
- (C) 2 - F421218 HEX NUT

METRIC STOCK

- (A) 1 - STL PLT ASTM A-36 20 X 40 X 150
- (B) 1 - STL TUBG ASTM A-36 50 X 50 X 4 X 150
- (C) 2 - F421218 HEX NUT

SEE PAGE B-1.1 FOR GLOBAL MATERIALS CHART

* LOCATE HOLE, NUT & WELD SEAM ON SAME SIDE OF TUBING

COVER SPACER ALV150

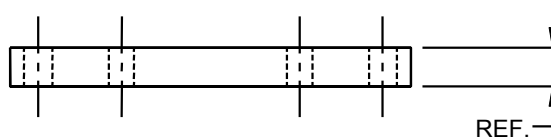
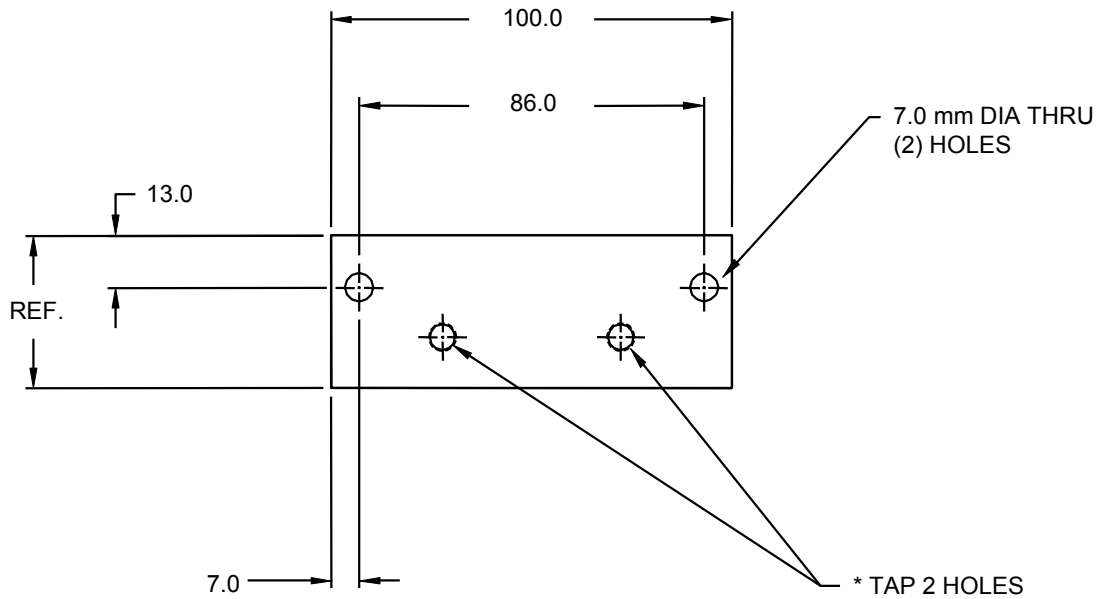

INCH STOCK
 STL PLT ASTM A-36 3/8" X 1 1/2" X 100mm

METRIC STOCK
 STL PLT ASTM A-36 10 X 40 X 100

SEE PAGE B-1.1 FOR GLOBAL MATERIALS CHART

* TAPPED HOLE DIMENSION AND SIZES FOR LIGHT SCREEN
 ATTACHMENT WILL BE CONTINGENT ON THE LIGHT SCREEN MOUNTING OPTION.

A

COVER SPACER ALV160

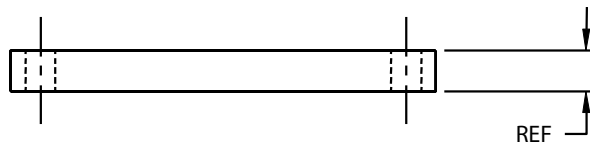
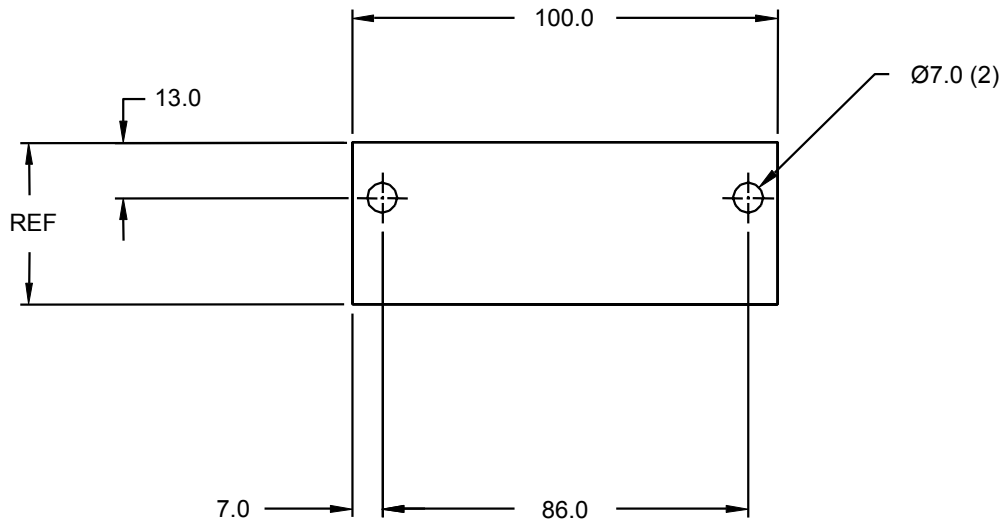

INCH STOCK
2 - STL PLT ASTM A-36 3/8" X 1 1/2" X 100mm
METRIC STOCK
2 - STL PLT ASTM A-36 10 X 40 X 100
SEE PAGE B-1.1 FOR GLOBAL MATERIALS CHART

A

SHAFT ALV170 - 570

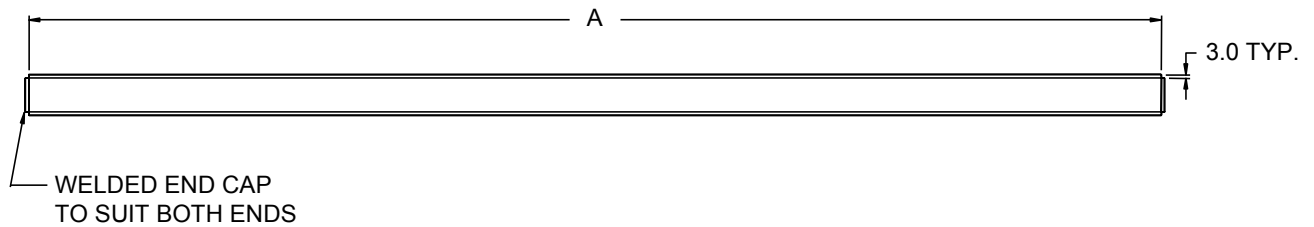

INCH STOCK
 STL TUBG ASTM-500 GRADE B 1 1/2" X 1 1/2" X 1/4" X 'A' DIM

METRIC STOCK
 STL TUBG ASTM-500 GRADE B 40 X 40 X 5 X 'A' DIM

SEE PAGE B-1.1 FOR GLOBAL MATERIALS CHART

NAAMS CODE	LIGHT SCREEN LENGTH	A MM
ALV170	24"	711.0
ALV270	36"	1016.0
ALV370	48"	1321.0
ALV470	60"	1626.0
ALV570	72"	1930.0

A

COVER

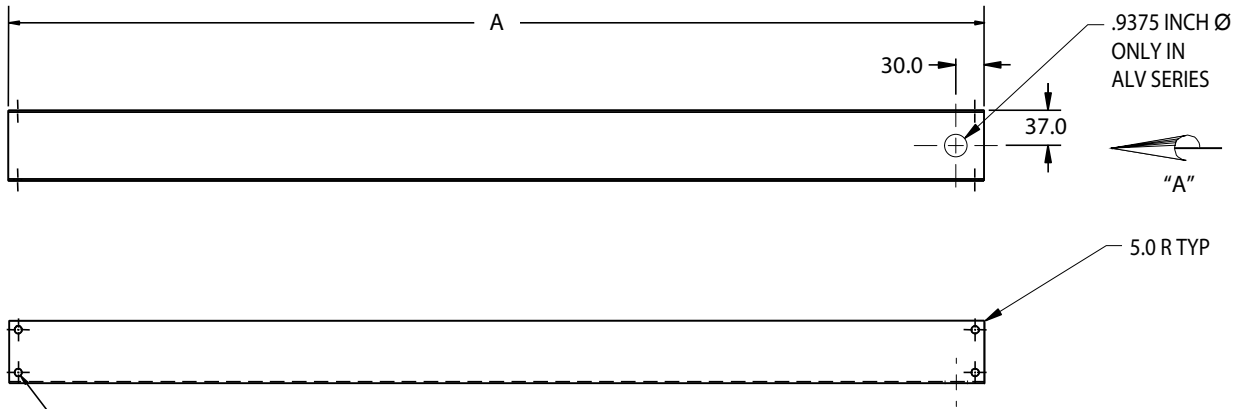

(*) CLEARANCE HOLES FOR ALLEN WRENCH ACCESS

(2) HOLES ~ (2) PLACES LOCATE AT ASSEMBLY ~ FAR SIDE CLEARANCE HOLES

(2) HOLES ~ (2) PLACES LOCATE AT ASSEMBLY ~ NEAR SIDE CLEARANCE HOLES

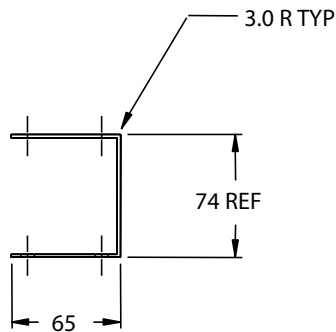

ALV180 - ALV580
 14 GA X 200 mm X A HRS

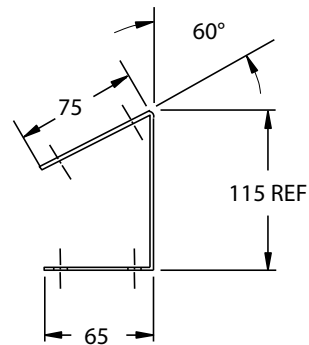

ALH180 - ALH580
 14 GA X 250 mm X A HRS

VIEW IN DIRECTION "A"

* NOTE: DIMENSIONS AND SIZES FOR CLEARANCE HOLES
 WILL BE CONTINGENT ON THE LIGHT SCREEN MOUNTING
 OPTIONS.

NAAMS CODE	LIGHT SCREEN LENGT	A
ALV180	24"	800.0
ALV280	36"	1105.0
ALV380	48"	1410.0
ALV480	60"	1715.0
ALV580	72"	2020.0

NAAMS CODE	LIGHT SCREEN LENGT	A
ALH180	24"	711.0
ALH280	36"	1016.0
ALH380	48"	1321.0
ALH480	60"	1626.0
ALH580	72"	1930.0

B

A

C

HORIZONTAL LIGHT SCREEN ASSEMBLY

GLOBAL STANDARD COMPONENTS



Assembly

02/02/12

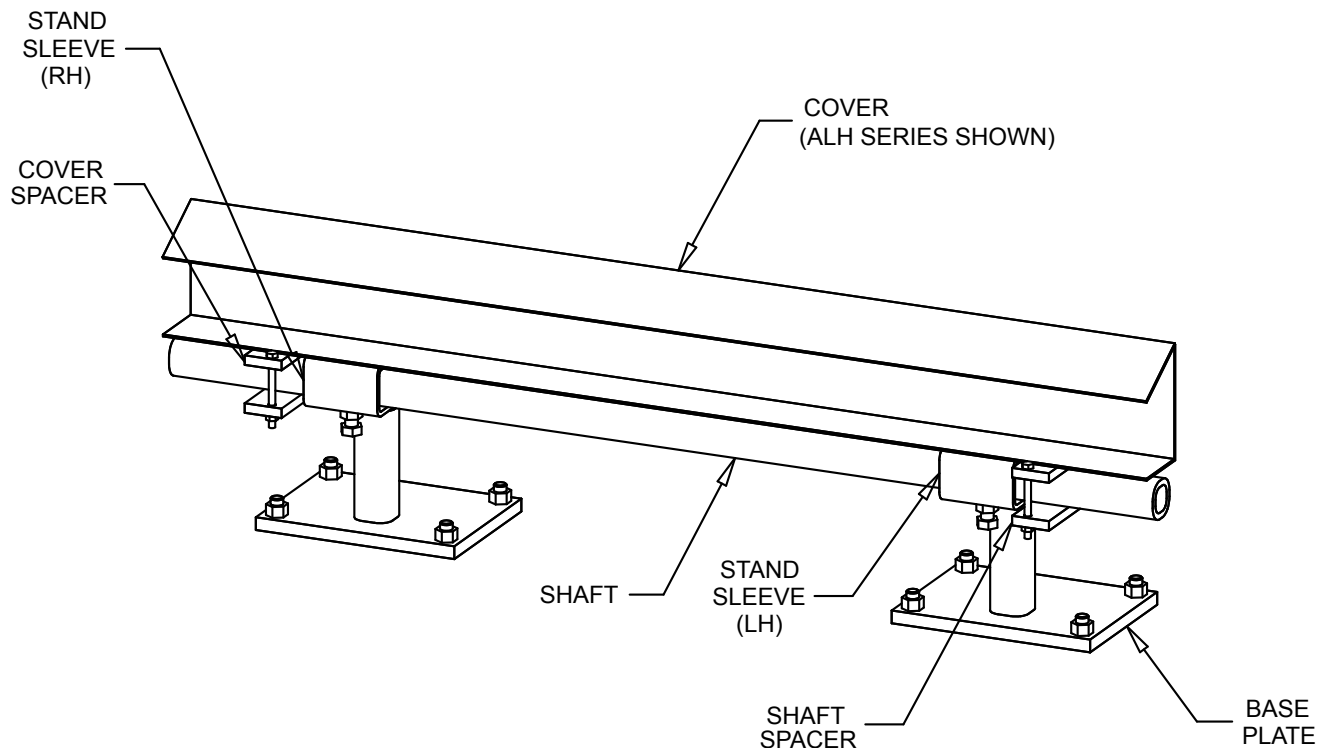

B
A

ASSEMBLY	BASE PLATE	STAND SLEEVE (R. H.)	STAND SLEEVE (L. H.)	COVER SPACER*	SHAFT SPACER*	SHAFT*	COVER	
ALH100	ALH110 (2 Req.)	ALH120	ALH130	ALV150 (2 Req.)	ALV160 (2 Req.)	ALV170	ALV180*	ALH180
ALH200						ALV270	ALV280*	ALH280
ALH300						ALV370	ALV380*	ALH380
ALH400						ALV470	ALV480*	ALH480
ALH500						ALV570	ALV580*	ALH580

C

* ALSO USED ON VERTICAL SCREEN ALV100 - ALV500

BASE PLATE ALH110

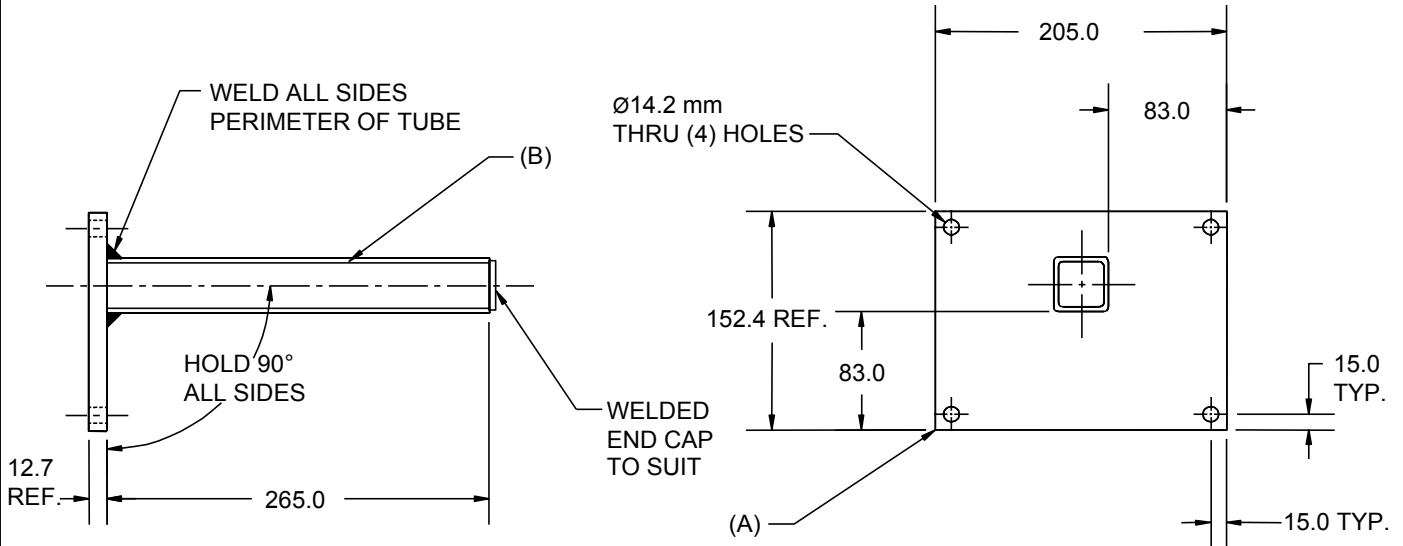

- INCH STOCK
 (A) 1 - STL PLT ASTM A-36 1/2" X 6" X 205mm
 (B) 1 - STL TUBG ASTM-500 GRADE B 1 1/2" X 1 1/2" X 1/4" X 265mm
- METRIC STOCK
 (A) 1 - STL PLT ASTM A-36 12 X 152.4 X 205
 (B) 1 - STL TUBG ASTM-500 GRADE B 40 X 40 X 5 X 265

SEE PAGE B-1.1 FOR GLOBAL MATERIALS CHART

STAND SLEEVE (R.H.) ALH120

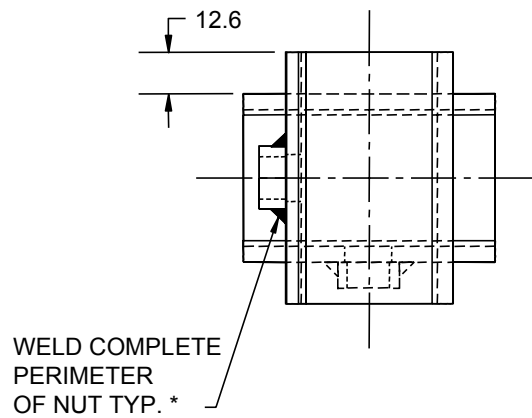
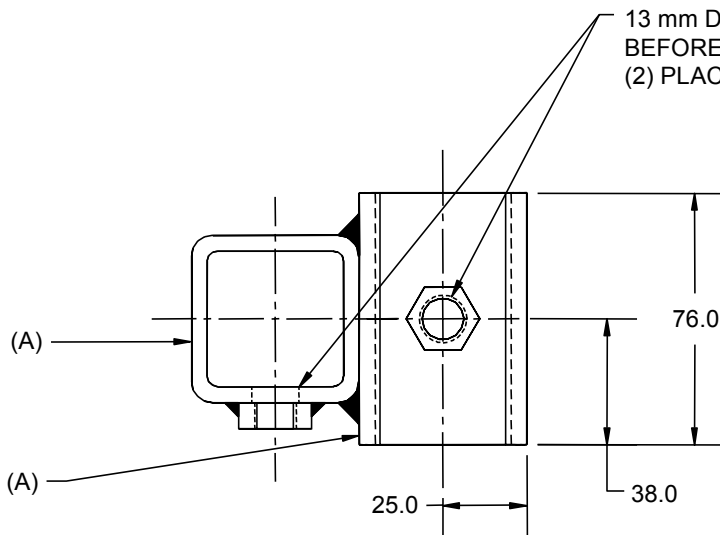
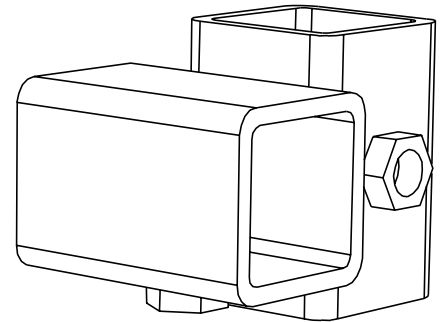
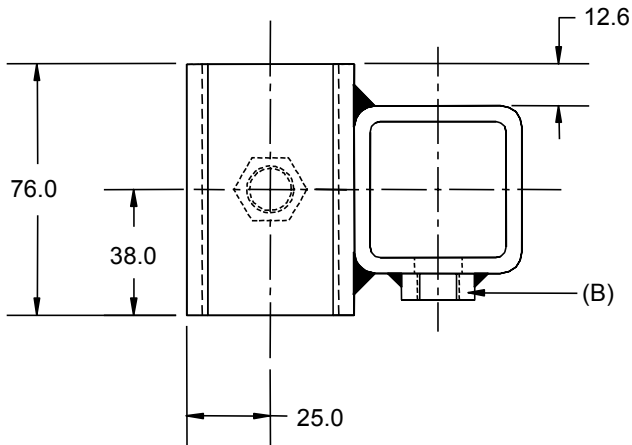

INCH STOCK
 (A) 2 - STL TUBG ASTM-500 GRADE B 2" X 2" X 3/16" X 76.0mm
 (B) 1 - F421218 HEX NUT

METRIC STOCK
 (A) 2 - STL TUBG ASTM-500 GRADE B 50 X 50 X 4 X 76.0
 (B) 1 - F421218 HEX NUT

SEE PAGE B-1.1 FOR GLOBAL MATERIALS CHART

* LOCATE HOLE, NUT & WELD SEAM ON SAME SIDE OF TUBING

A

B

STAND SLEEVE (L.H.) ALH130

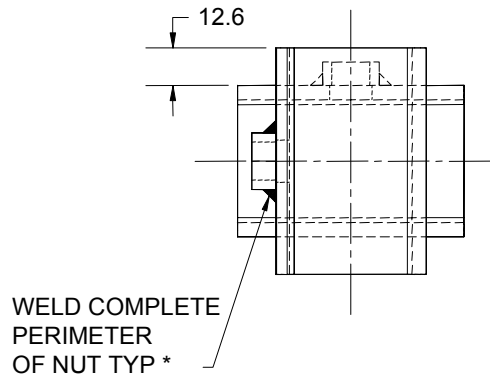
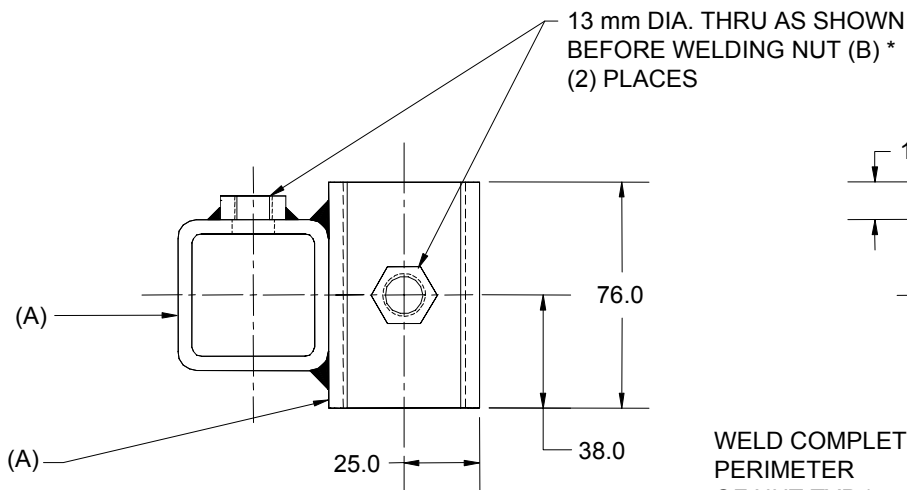
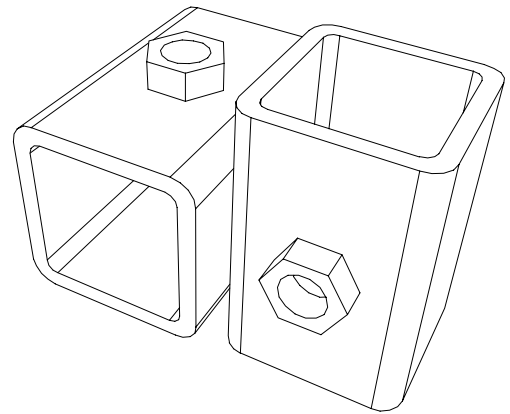
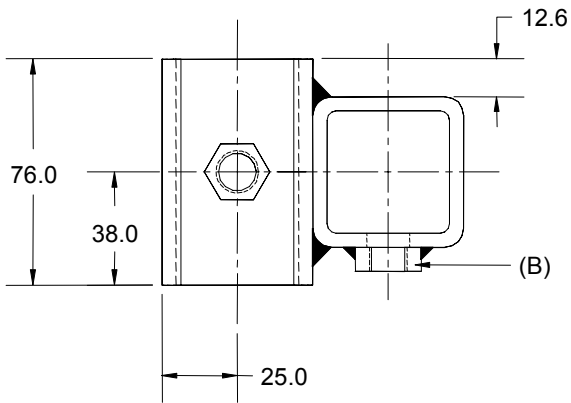

INCH STOCK
 (A) 2 - STL TUBG ASTM-500 GRADE B 2" X 2" X 3/16" X 76.0mm
 (B) 1 - F421218 HEX NUT

METRIC STOCK
 (A) 2 - STL TUBG ASTM-500 GRADE B 50 X 50 X 4 X 76.0
 (B) 1 - F421218 HEX NUT

SEE PAGE B-1.1 FOR GLOBAL MATERIALS CHART

* LOCATE HOLE, NUT & WELD SEAM ON SAME SIDE OF TUBING

A

B

PALM BUTTON STAND BASE

APB001

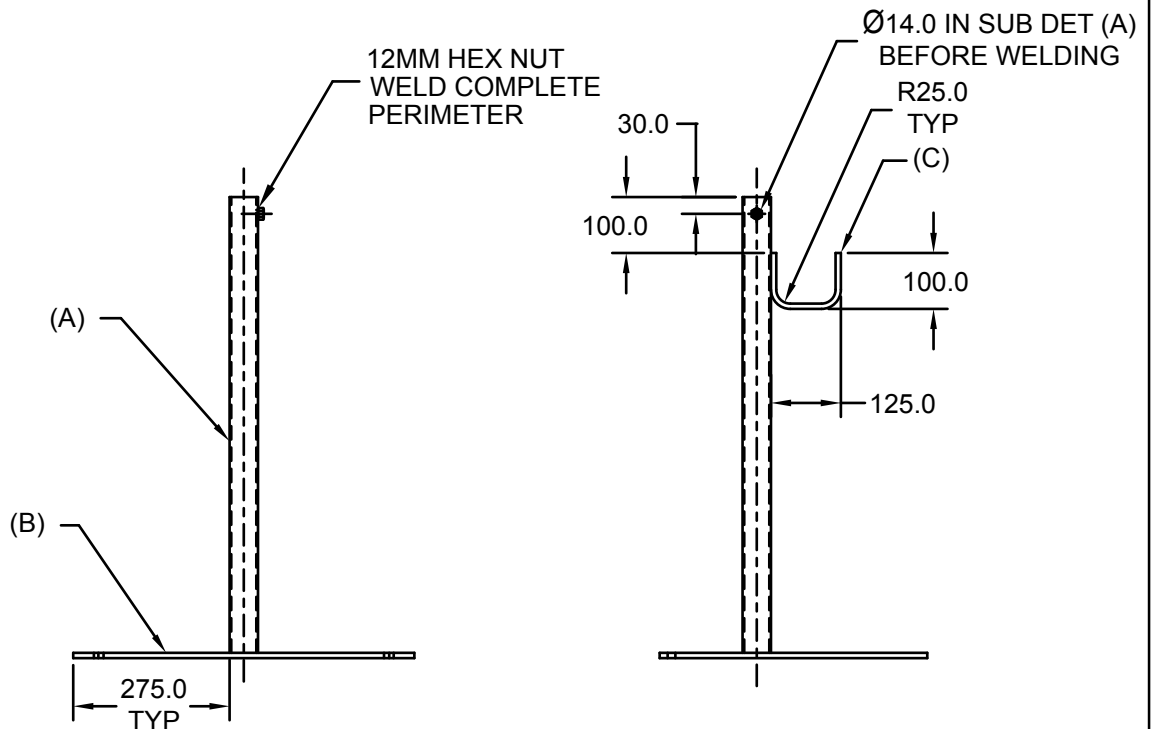
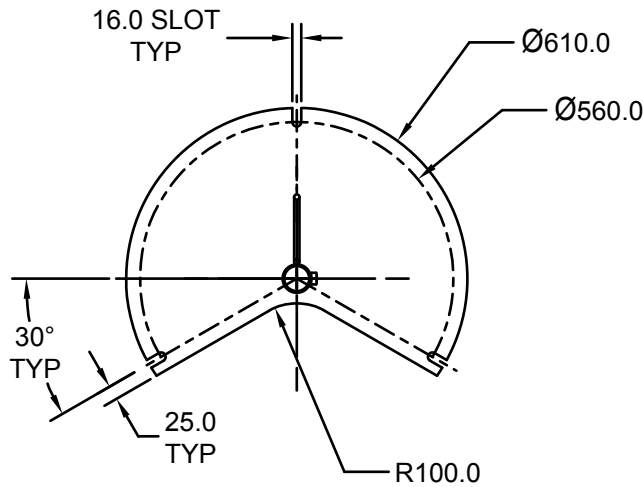

WELDMENT

INCH STOCK

(A) 1 - BLACK PIPE SCHEDULE 40 - 2" NOM X 815.0mm
 (B) 1 - STL PLATE 3/8" X 610.0mm X 460.0mm
 (C) 1 - SAE 1020 HRS 3/8" DIA X 285.0mm

METRIC STOCK

(A) 1 - BLACK PIPE SCHEDULE 40 - 2" NOM X 815.0
 (B) 1 - STL PLATE 10 X 610.0mm X 460.0mm
 (C) 1 - SAE 1020 HRS 10 DIA X 285.0mm

SEE PAGE B-1.1 FOR GLOBAL MATERIALS CHART

PALM BUTTON STAND EXTENSION

APB002

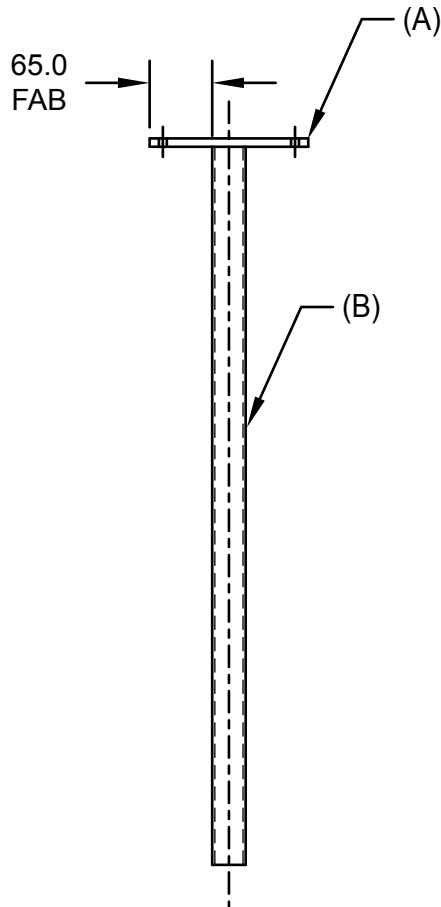
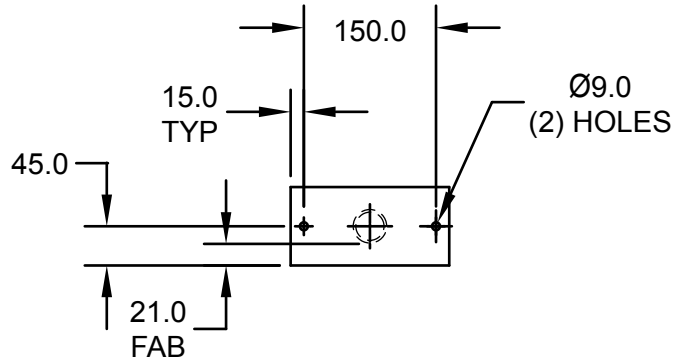

WELDMENT

INCH STOCK

(A) 1 - SAE 1020 HRS 3/8" X 3 1/2" X 180.0mm
 (B) 1 - BLACK PIPE SCHEDULE 40 - 1 1/2" NOM X 550.0mm

METRIC STOCK

(A) 1 - SAE 1020 HRS 10 X 90 X 180.0
 (B) 1 - BLACK PIPE SCHEDULE 40 - 1 1/2" NOM X 550.0mm

SEE PAGE B-1.1 FOR GLOBAL MATERIALS CHART

TIP DRESSER STAND

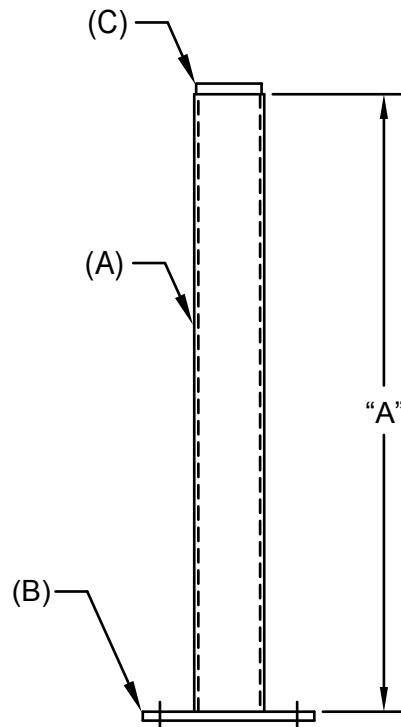
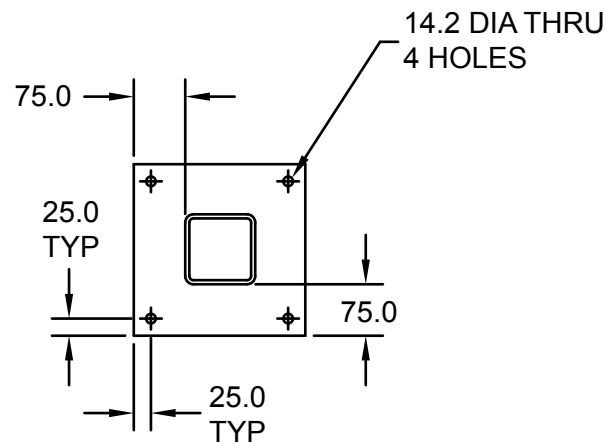

NAAMS CODE	"A"
ATD060	600
ATD090	900
ATD120	1200
ATD180	1800

WELDMENT

INCH STOCK

- | | |
|--------------------------------------|--------------------------|
| (A) 1 - ASTM A-500 S GRADE B STL TBG | 4" X 4" X 1/4 W/T X "A" |
| (B) 1 - ASTM A-36 STL PLT | 1/2" X 250.0MM X 250.0MM |
| (C) 1 - ASTM A-36 STL PLT | 1/8" X 95.0MM X 95.0MM |

NOTE:
VENT TO SUIT

METRIC STOCK

- | | |
|--------------------------------------|---------------------------|
| (A) 1 - ASTM A-500 S GRADE B STL TBG | 100MM X 100MM X 6MM X "A" |
| (B) 1 - ASTM A-36 STL PLT | 13MM X 250.0MM X 250.0MM |
| (C) 1 - ASTM A-36 STL PLT | 3MM" X 95.0MM X 95.0MM |

SEE PAGE B-1.1 FOR GLOBAL MATERIALS CHART

DEVISE NET MOUNTING BRACKET ADN001

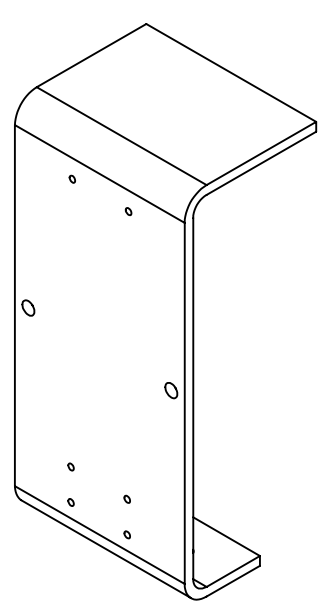
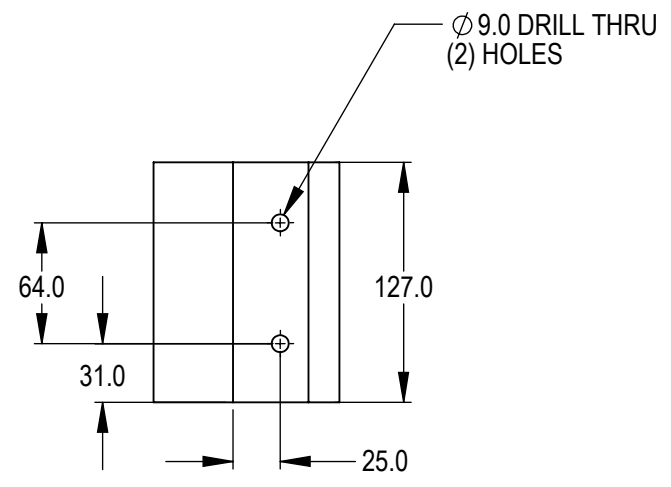
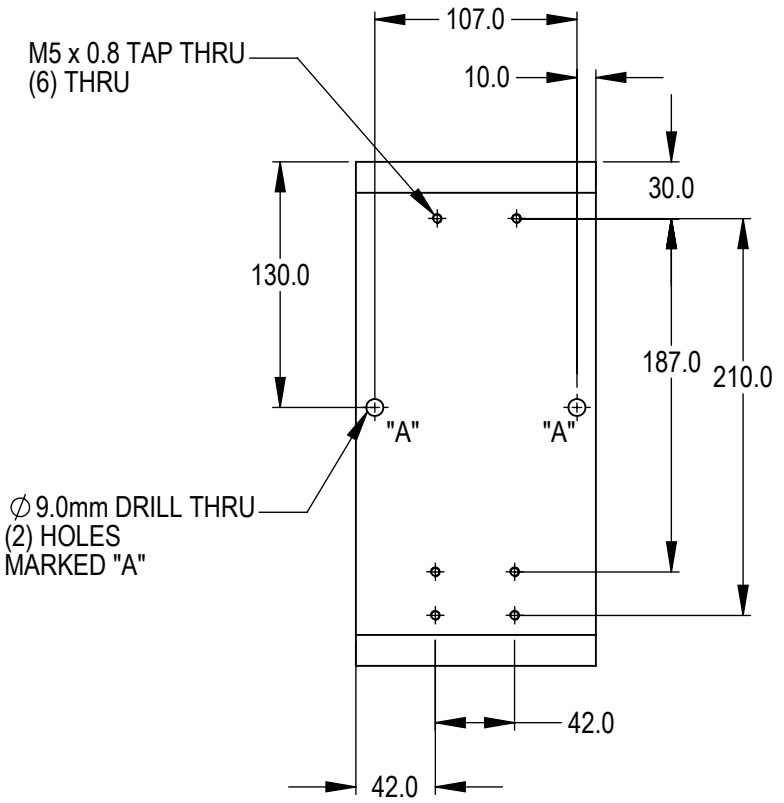
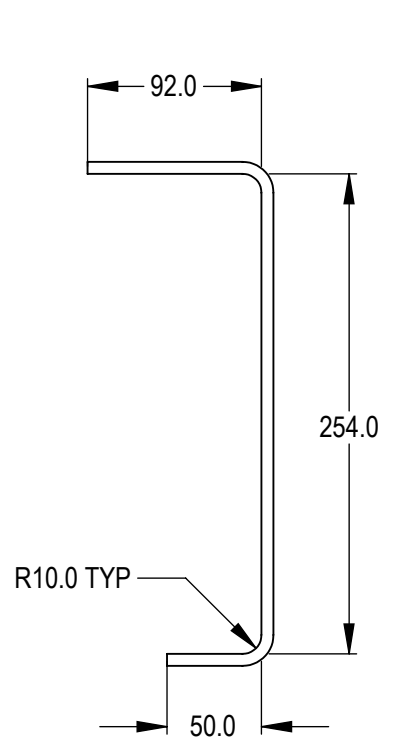

ASTM A-36 H.R.S. - 1/4" x 5" x 397mm
APPROX. WT. = 2.0 KG
PAINT SPEC: FLAT BLACK