

WEAR COMPONENTS INDEX

PAGE	DATE	SERIES	DESCRIPTION
W-1	11/04/21		Wear Components Index
W-2	03/31/10	W01, W02 & W03	Discontinued
W-3	08/24/07	W01, W02 & W03	Discontinued
W-4	08/24/07	W11, W21 & W31	Cam Dwell Wear Plate
W-5	04/16/96	W51, W53, W55, W57, W59, W41, W43, W45, W47 & W49	Wear Strips (Self Lubricated)
W-6	04/16/96	W51, W53, W41, W43	Wear Strip Coding (Self Lubricated)
W-7	04/16/96	W55, W57, W45, W47	Wear Strip Coding (Self Lubricated)
W-8	04/16/96	W59, W49	Wear Strip Coding (Self Lubricated)
W-9	03/15/07	W05, W06 & W07	Wear Plates
W-10	05/02/08	W05, W06 & W07	Steel Wear Plate w/Graphite Plugs Coding Steel Wear Plate w/o Graphite Plugs Coding Aluminum Bronze Wear Plate w/Graphite Plugs Coding
W-11	08/01/11	W08, W09	Cam Slide Side Wear Plates
W-12	02/12/24	W10	Wear Plate Visual Wear Indicator Standard

WEAR PLATES

(W01, W02, W03 & W04 SERIES)

6.3 ALL OVER EXCEPT WHERE OTHERWISE STATED

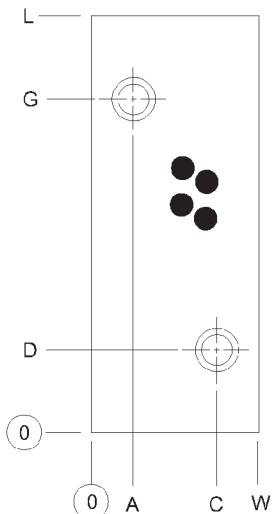

PATTERN A

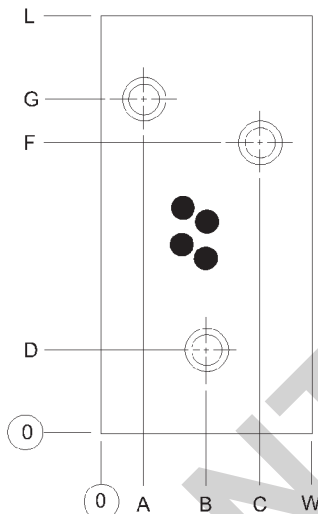

PATTERN B

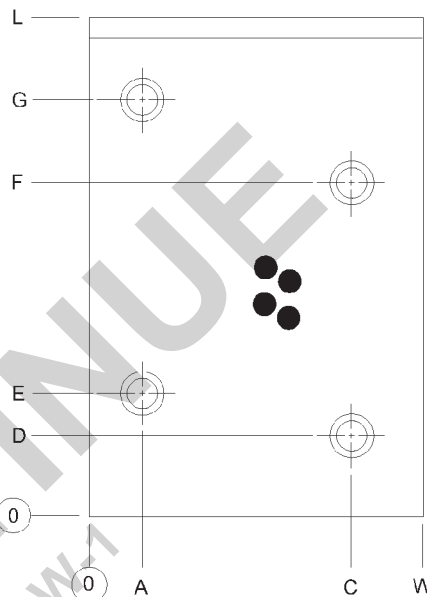

PATTERN C

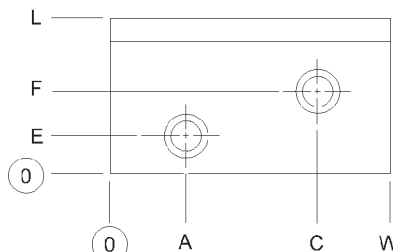

PATTERN D

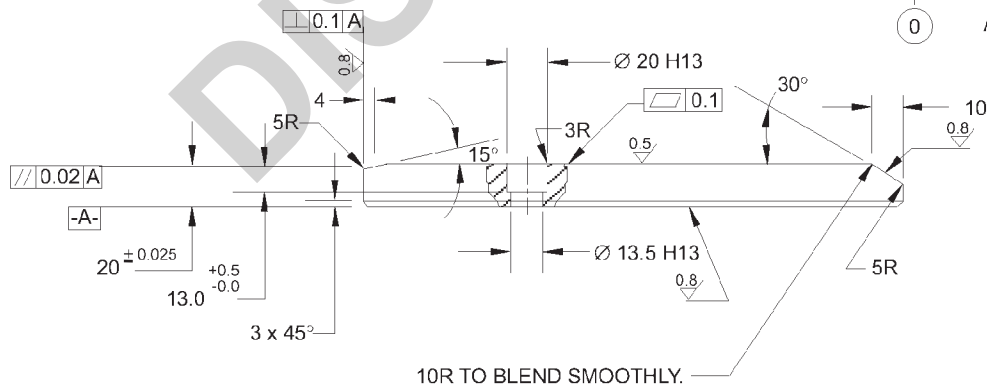

NOTES & SPECIFICATIONS:

- (B) Wear plates with sintered surface.
- (G) Steel wear plates with graphite plugs.
- (X) Steel wear plates with no graphite plugs.
- (Y) Aluminum bronze wear plates with graphite plugs.

Screw hole locations ± 0.25

All dimensions ± 0.25 unless otherwise noted.

Evenly distributed graphite plugs to cover 25-30% of the area requiring lubrication.

Remove all sharp edges around top surface of wear plate.

CODING ON FOLLOWING PAGE

WEAR PLATE CODING

(W01, W02, W03 & W04 SERIES)

GLOBAL STANDARD COMPONENTS



Stamping

12/02/19

NAAMS CODE NO. (G)*	NAAMS CODE NO. (X)*	NAAMS CODE NO. (Y)*	NAAMS CODE NO. (B)*	WIDTH	LENGTH	A	B	C	D	E	F	G	SCREW HOLES	
													No.	PATTERN
W015010	W025010	W035010	W045010	50	100	25		25	30			60	2	A
W015015	W025015	W035015	W045015	50	150	25		25	30			110	2	A
W015020	W025020	W035020	W045020	50	200	25		25	40			160	2	A
W018010	W028010	W038010	W048010	80	100	20		60	30			60	2	A
W018015	W028015	W038015	W048015	80	150	20		60	30			110	2	A
W018020	W028020	W038020	W048020	80	200	20		60	40			160	2	A
W018025	W028025	W038025	W048025	80	250	20		60	40			210	2	A
W018031	W028031	W038031	W048031	80	315	20	40	60	40		250	275	3	B
W011050	W021050	W031050	W041050	100	50	22		78		14	27		2	D
W011080	W021080	W031080	W041080	100	80	22		78		30	50		2	D
W011010	W021010	W031010	W041010	100	100	22		78	30			60	2	A
W011015	W021015	W031015	W041015	100	150	22		78	30			110	2	A
W011020	W021020	W031020	W041020	100	200	22	50	78	40		135	160	3	B
W011025	W021025	W031025	W041025	100	250	22	50	78	40		185	210	3	B
W011031	W021031	W031031	W041031	100	315	22	50	78	40		250	275	3	B
W011280	W021280	W031280	W041280	125	80	25		100		30	50		2	D
W011210	W021210	W031210	W041210	125	100	25		100	30			60	2	A
W011215	W021215	W031215	W041215	125	150	25		100	30			110	2	A
W011220	W021220	W031220	W041220	125	200	25	62	100	40		135	160	3	B
W011225	W021225	W031225	W041225	125	250	25	62	100	40		185	210	3	B
W011231	W021231	W031231	W041231	125	315	25		100	40	65	250	275	4	C
W011610	W021610	W031610	W041610	160	100	30		130	30			60	2	A
W011615	W021615	W031615	W041615	160	150	30		130	30			110	2	A
W011620	W021620	W031620	W041620	160	200	30	80	130	40		135	160	3	B
W011625	W021625	W031625	W041625	160	250	30		130	40	65	185	210	4	C
W011631	W021631	W031631	W041631	160	315	30		130	40	65	250	275	4	C

MATERIAL: S.A.E. 1010 FULL HARD
SEE PAGE B-1.1 FOR GLOBAL MATERIALS CHART

- *(B) Wear plates with sintered surface.
- *(G) Steel wear plates with graphite plugs.
- *(X) Steel wear plates with no graphite plugs.
- *(Y) Aluminum bronze C95900 wear plates with graphite plugs.

A

B

D

C

D

CAM DWELL WEAR PLATES

(W11, W21, & W31 SERIES)

GLOBAL STANDARD COMPONENTS



Stamping

08/24/07

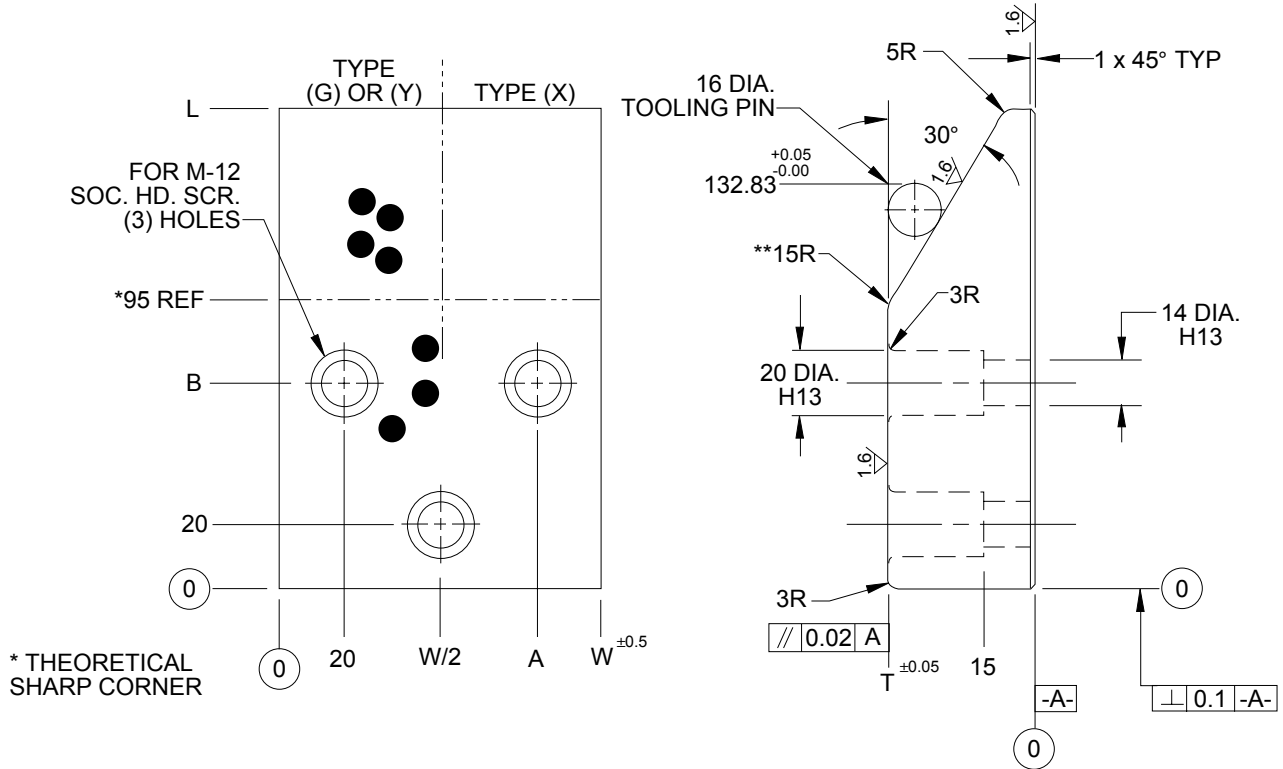

* THEORETICAL SHARP CORNER

NAAMS CODE (G)	NAAMS CODE (X)	NAAMS CODE (Y)	T	W	L	A	B
W111210	W211210	W311210	30	100	125	80	70
W111212	W211212	W311212	30	125	125	105	70
W111216	W211216	W311216	30	160	125	140	70
W111510	W211510	W311510	45	100	150	80	65
W111512	W211512	W311512	45	125	150	105	65
W111516	W211516	W311516	45	160	150	140	65
W111710	W211710	W311710	60	100	170	80	65
W111712	W211712	W311712	60	125	170	105	65
W111716	W211716	W311716	60	160	170	140	65

NOTES & SPECIFICATIONS:

- (G) Steel with graphite plugs.
- (X) Steel with no graphite plugs.
- (Y) Aluminum bronze C95900 with graphite plugs.

Screw hole locations ± 0.25

All dimensions are $+0.25$ unless otherwise noted.

Evenly distributed graphite plugs to cover 20-30% of the area that requires lubrication.

**Keep graphite plugs approximately 5 mm away from 15R radius.

A

WEAR STRIPS

(W41, W43, W45, W47 & W49 SERIES)
(W51, W53, W55, W57 & W59 SERIES)
(W61, W63, W65, W67 & W69 SERIES)

A

SELF-LUBRICATED

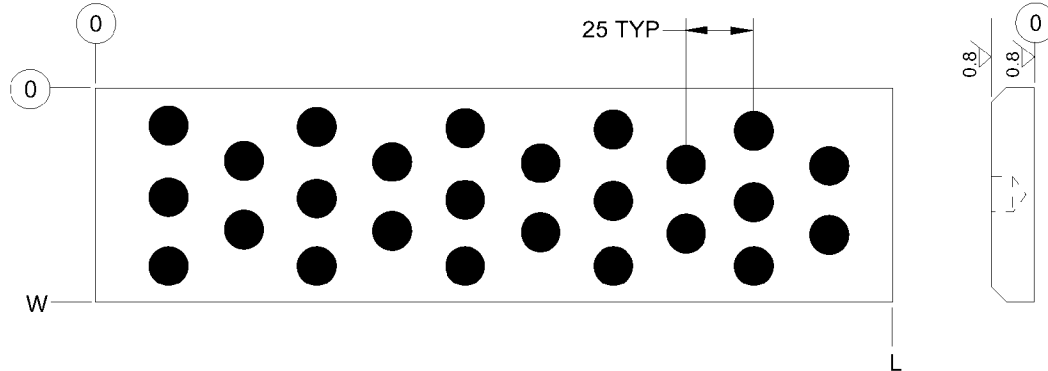

NOTES & SPECIFICATIONS:

Available in bronze plated steel or solid bronze,

- (Y) Bronze
- (P) Bronze plated steel
- (B) Sintered surface

SUGGESTIONS FOR FASTENING

Normal procedure is to use plug location for screw hole location

For 10 thicknesses

Suggest: M6 flathead or socket head screw maximum

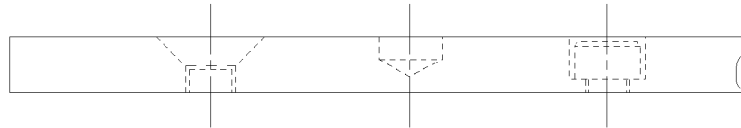

For 12, 15, 20 thicknesses

Suggest: M10 flathead or socket head screw maximum

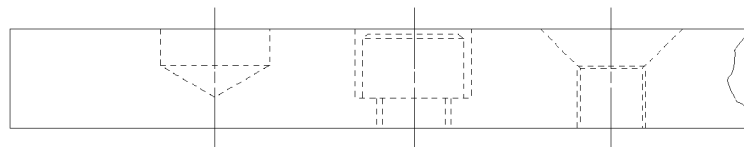

Evenly distributed graphite plugs to cover 25-30% of the area requiring lubrication.

CODING ON FOLLOWING PAGES

WEAR STRIP CODING

(W41 & W43 SERIES)
(W51 & W53 SERIES)
(W61 & W63 SERIES)

GLOBAL STANDARD COMPONENTS



Stamping

03/23/04

NAAMS CODE NO. *(Y)	NAAMS CODE NO. *(P)	NAAMS CODE NO. *(B)	W	T	L
W511025	W411025	W611025	25	10	150
W511040	W411040	W611040	40		
W511050	W411050	W611050	50		
W511063	W411063	W611063	63		
W511075	W411075	W611075	75		
W511010	W411010	W611010	100		
W511012	W411012	W611012	125		
W511015	W411015	W611015	150		
W511225	W411225	W611225	25	12	
W511240	W411240	W611240	40		
W511250	W411250	W611250	50		
W511263	W411263	W611263	63		
W511275	W411275	W611275	75		
W511210	W411210	W611210	100		
W511212	W411212	W611212	125		
W511215	W411215	W611215	150		
W511525	W411525	W611525	25	15	
W511540	W411540	W611540	40		
W511550	W411550	W611550	50		
W511563	W411563	W611563	63		
W511575	W411575	W611575	75		
W511510	W411510	W611510	100		
W511512	W411512	W611512	125		
W511515	W411515	W611515	150		
W512025	W412025	W612025	25	20	
W512040	W412040	W612040	40		
W512050	W412050	W612050	50		
W512063	W412063	W612063	63		
W512075	W412075	W612075	75		
W512010	W412010	W612010	100		
W512012	W412012	W612012	125		
W512015	W412015	W612015	150		

NAAMS CODE NO. *(Y)	NAAMS CODE NO. *(P)	NAAMS CODE NO. *(B)	W	T	L
W531025	W431025	W631025	25	10	300
W531040	W431040	W631040	40		
W531050	W431050	W631050	50		
W531063	W431063	W631063	63		
W531075	W431075	W631075	75		
W531010	W431010	W631010	100		
W531012	W431012	W631012	125		
W531015	W431015	W631015	150		
W531225	W431225	W631225	25	12	
W531240	W431240	W631240	40		
W531250	W431250	W631250	50		
W531263	W431263	W631263	63		
W531275	W431275	W631275	75		
W531210	W431210	W631210	100		
W531212	W431212	W631212	125		
W531215	W431215	W631215	150		
W531525	W431525	W631525	25	15	
W531540	W431540	W631540	40		
W531550	W431550	W631550	50		
W531563	W431563	W631563	63		
W531575	W431575	W631575	75		
W531510	W431510	W631510	100		
W531512	W431512	W631512	125		
W531515	W431515	W631515	150		
W532025	W432025	W632025	25	20	
W532040	W432040	W632040	40		
W532050	W432050	W632050	50		
W532063	W432063	W632063	63		
W532075	W432075	W632075	75		
W532010	W432010	W632010	100		
W532012	W432012	W632012	125		
W532015	W432015	W632015	150		

A

- *(B) Sintered surface.
- *(P) Bronze plated steel
- *(Y) Bronze

CODING CONTINUED ON FOLLOWING PAGE

WEAR STRIP CODING

(W45 & W47 SERIES)
(W55 & W57 SERIES)
(W66 & W67 SERIES)

NAAMS CODE NO. *(Y)	NAAMS CODE NO. *(P)	NAAMS CODE NO. *(B)	W	T	L
W551025	W451025	W651025	25	10	600
W551040	W451040	W651040	40		
W551050	W451050	W651050	50		
W551063	W451063	W651063	63		
W551075	W451075	W651075	75		
W551010	W451010	W651010	100		
W551012	W451012	W651012	125		
W551015	W451015	W651015	150		
W551225	W451225	W651225	25	12	
W551240	W451240	W651240	40		
W551250	W451250	W651250	50		
W551263	W451263	W651263	63		
W551275	W451275	W651275	75		
W551210	W451210	W651210	100		
W551212	W451212	W651212	125		
W551215	W451215	W651215	150		
W551525	W451525	W651525	25	15	
W555540	W451540	W651540	40		
W551550	W451550	W651550	50		
W551563	W451563	W651563	63		
W551575	W451575	W651575	75		
W551510	W451510	W651510	100		
W551512	W451512	W651512	125		
W551515	W451515	W651515	150		
W552025	W452025	W652025	25	20	
W552040	W452040	W652040	40		
W552050	W452050	W652050	50		
W552063	W452063	W652063	63		
W552075	W452075	W652075	75		
W552010	W452010	W652010	100		
W552012	W452012	W652012	125		
W552015	W452015	W652015	150		

NAAMS CODE NO. *(Y)	NAAMS CODE NO. *(P)	NAAMS CODE NO. *(B)	W	T	L
W571025	W471025	W671025	25	10	1000
W571040	W471040	W671040	40		
W571050	W471050	W671050	50		
W571063	W471063	W671063	63		
W571075	W471075	W671075	75		
W571010	W471010	W671010	100		
W571012	W471012	W671012	125		
W571015	W471015	W671015	150		
W571225	W471225	W671225	25	12	
W571240	W471240	W671240	40		
W571250	W471250	W671250	50		
W571263	W471263	W671263	63		
W571275	W471275	W671275	75		
W571210	W471210	W671210	100		
W571212	W471212	W671212	125		
W571215	W471215	W671215	150		
W571525	W471525	W671525	25	15	
W571540	W471540	W671540	40		
W571550	W471550	W671550	50		
W571563	W471563	W671563	63		
W571575	W471575	W671575	75		
W571510	W471510	W671510	100		
W571512	W471512	W671512	125		
W571515	W471515	W671515	150		
W572025	W472025	W672025	25	20	
W572040	W472040	W672040	40		
W572050	W472050	W672050	50		
W572063	W472063	W672063	63		
W572075	W472075	W672075	75		
W572010	W472010	W672010	100		
W572012	W472012	W672012	125		
W572015	W472015	W672015	150		

A

*(B) Sintered surface.
*(P) Bronze plated steel
*(Y) Bronze

CODING CONTINUED ON FOLLOWING PAGE

WEAR STRIP CODING

(W49 SERIES)
(W59 SERIES)
(W69 SERIES)

GLOBAL STANDARD COMPONENTS



Stamping

03/23/04

NAAMS CODE NO. *(Y)	NAAMS CODE NO. *(P)	NAAMS CODE NO. *(B)	W	T	L
W591025	W491025	W691025	25	10	1200
W591040	W491040	W691040	40		
W591050	W491050	W691050	50		
W591063	W491063	W691063	63		
W591075	W491075	W691075	75		
W591010	W491010	W691010	100		
W591012	W491012	W691012	125		
W591015	W491015	W691015	150		
W591225	W491225	W691225	25	12	
W591240	W491240	W691240	40		
W591250	W491250	W691250	50		
W591263	W491263	W691263	63		
W591275	W491275	W691275	75		
W591210	W491210	W691210	100		
W591212	W491212	W691212	125		
W591215	W4912615	W691215	150		
W591525	W491525	W691525	25	15	
W591540	W491540	W691540	40		
W591550	W491550	W691550	50		
W591563	W491563	W691563	63		
W591575	W491575	W691575	75		
W591510	W491510	W691510	100		
W591512	W491512	W691512	125		
W591515	W491515	W691515	150		
W592025	W492025	W692025	25	20	
W592040	W492040	W692040	40		
W592050	W492050	W692050	50		
W592063	W492063	W692063	63		
W592075	W492075	W692075	75		
W592010	W492010	W692010	100		
W592012	W492012	W692012	125		
W592015	W492015	W692015	150		

A

- *(B) Sintered surface.
- *(P) Bronze plated steel
- *(Y) Bronze

WEAR PLATES

(W05, W06 & W07 SERIES)

6.3 ALL OVER EXCEPT WHERE OTHERWISE STATED

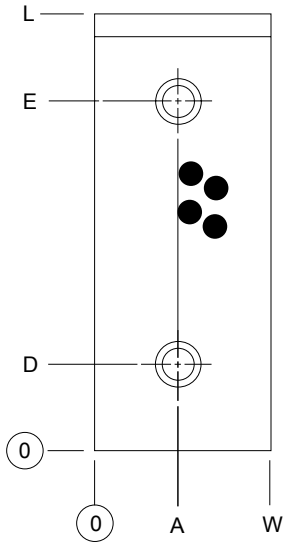

PATTERN A

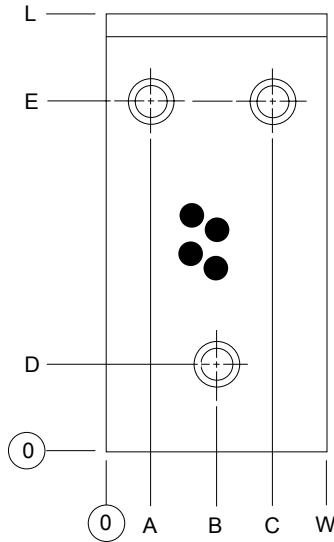

PATTERN B

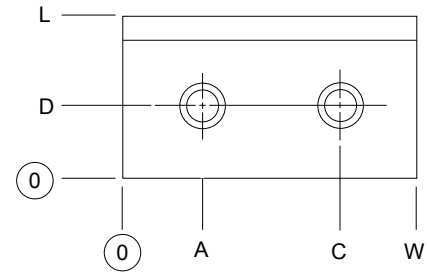

PATTERN C

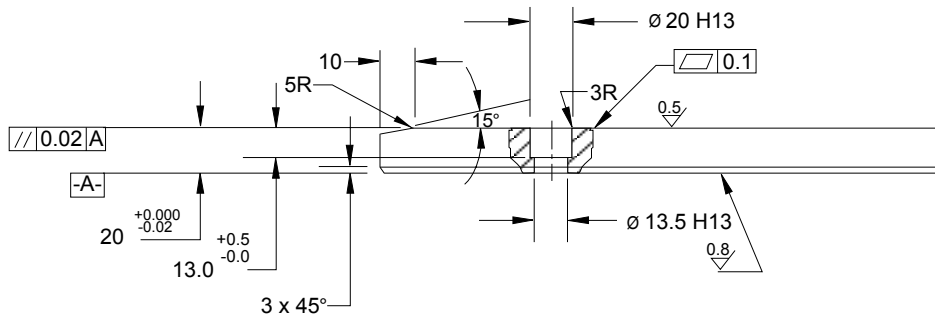

To VDI 3357

Screw hole locations ± 0.25

All dimensions ± 0.25 unless otherwise noted.

Evenly distributed graphite plugs to cover 20-25% of the area requiring lubrication.

Remove all sharp edges around top surface of wear plate.

CODING ON FOLLOWING PAGE

WEAR PLATES

(W05, W06 & W07 SERIES)

NAAMS CODE NO. (G) ¹	NAAMS CODE NO. (X) ²	NAAMS CODE NO. (Y) ³	WIDTH (W)	LENGTH (L)	A	B	C	D	E	HOLES	
										No.	PATTERN
W050510	W060510	W070510	50	100	25	–	–	25	75	2	A
W050511	W060511	W070511	D I S C O N T I N U E D								
W050512	W060512	W070512	50	125	25	–	–	25	100	2	A
W050516	W060516	W070516	50	160	25	–	–	25	135	2	A
W050520	W060520	W070520	50	200	25	–	–	25	175	2	A
W050810	W060810	W070810	80	100	40	–	–	25	75	2	A
W050812	W060812	W070812	80	125	40	–	–	25	100	2	A
W050816	W060816	W070816	80	160	40	–	–	25	135	2	A
W050820	W060820	W070820	80	200	40	–	–	25	175	2	A
W051050	W061050	W071050	100	50	25	–	75	25	–	2	C
W051080	W061080	W071080	100	80	25	–	75	40	–	2	C
W051010	W061010	W071010	100	100	50	–	–	25	75	2	A
W051012	W061012	W071012	100	125	50	–	–	25	100	2	A
W051016	W061016	W071016	100	160	50	–	–	25	135	2	A
W051020	W061020	W071020	100	200	50	–	–	25	175	2	A
W051208	W061208	W071208	125	80	25	–	100	40	–	2	C
W051210	W061210	W071210	125	100	25	62.5	100	25	75	3	B
W051212	W061212	W071212	125	125	25	62.5	100	25	100	3	B
W051216	W061216	W071216	125	160	25	62.5	100	25	135	3	B
W051220	W061220	W071220	125	200	25	62.5	100	25	175	3	B
W051610	W061610	W071610	160	100	25	80	135	25	75	3	B
W051612	W061612	W071612	160	125	25	80	135	25	100	3	B
W051616	W061616	W071616	160	160	25	80	135	25	135	3	B
W051620	W061620	W071620	160	200	25	80	135	25	175	3	B

B

C

D

¹(G) Steel wear plates w ith graphite plugs
²(X) Steel wear plates with no graphite plugs
³(Y) Aluminum bronze C95900 wear plates with graphite plugs

A

CAM SLIDE SIDE WEAR PLATES

(W08 & W09 SERIES)

GLOBAL STANDARD COMPONENTS



Stamping

08/01/11

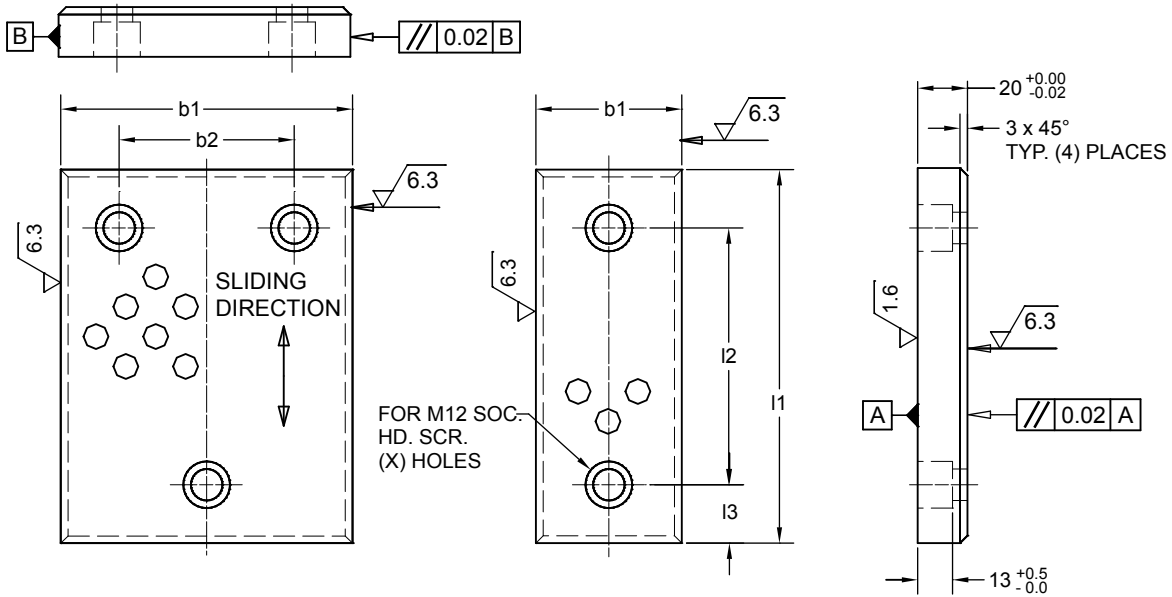

NAAMS CODE X^1	NAAMS CODE Y^2	WIDTH $b_1^{+0.05}_{-0.00}$	LENGTH $l_1^{+0.0}_{-0.2}$	l_3 ± 0.2	l_2 ± 0.2	b_2 ± 0.2	NO. OF SCREWS
W085010	W095010	50	100	25	50	—	2
W085012	W095012	50	125	25	75	—	2
W085016	W095016	50	160	25	110	—	2
W085020	W095020	50	200	25	150	—	2
W088010	W098010	80	100	25	50	—	2
W088012	W098012	80	125	25	75	—	2
W088016	W098016	80	160	25	110	—	2
W088020	W098020	80	200	25	150	—	2
W088025	W098025	80	250	40	170	—	2
W088031	W098031	80	315	40	235	—	2
W081210	W091210	125	100	25	50	75	3
W081212	W091212	125	125	25	75	75	3
W081216	W091216	125	160	25	110	75	3
W081220	W091220	125	200	25	150	75	3
W081225	W091225	125	250	40	170	75	3
W081231	W091231	125	315	40	235	75	3
W081610	W091610	160	100	25	50	110	3
W081612	W091612	160	125	25	75	110	3
W081616	W091616	160	160	25	110	110	3
W081620	W091620	160	200	25	150	110	3
W081625	W091625	160	250	40	170	110	3
W081631	W091631	160	315	40	235	110	3

MATERIAL: USE ONLY (X) AND (Y) MATERIAL, NO SUBSTITUTES

- 1.) TYPE (X) - STEEL (NO GRAPHITE PLUGS).
BS 970: PART 1: 1983-080M15 OR C15 K TO DIN 1652 OR 4140 OR 4150 CARBURIZE,
CASE DEPTH 1.3 - 1.5 mm, CASE HARDEN Rc 56 - 60.
- 2.) TYPE (Y) - ALUMINUM BRONZE WITH GRAPHITE PLUGS.
BS 1400 HTB3 OR DIN 1709 G-CuZn25Al5 OR ISO CuAl13Fe5 OR SAE-430B
EVENLY DISTRIBUTED GRAPHITE PLUGS TO COVER 20 - 30% OF THE AREA THAT REQUIRES LUBRICATION.

FINISH: BREAK ALL SHARP EDGES $0.5 \times 45^\circ$.

LABEL: EACH PART MUST BE PERMANENTLY MARKED WITH THE FULL ORDERING NUMBER AND MANUFACTURER'S BRAND.

WEAR PLATE VISUAL WEAR INDICATOR STANDARD (W10 Series)

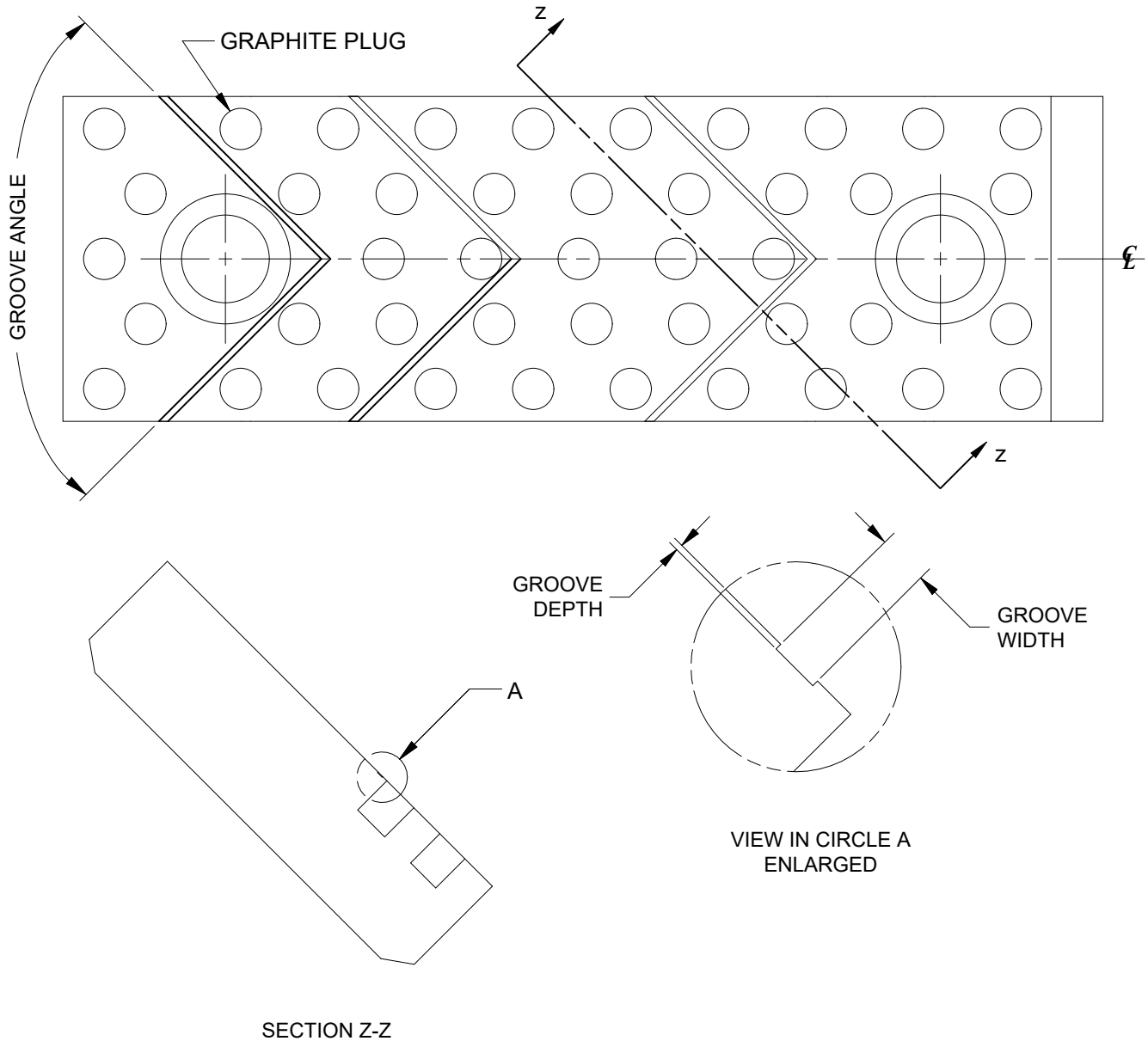

- TWO GROOVES MINIMUM ON SMALL PLATES
- 60mm MAXIMUM DISTANCE BETWEEN GROOVES
- END GROOVES SHOULD BE CLOSE TO THE ENDS, BUT NOT CLOSER THAN 15mm IF POSSIBLE
- GROOVES ARE NOT TO PASS THRU COUNTERBORED HOLES IF POSSIBLE
- GROOVES WIDTH WILL BE 1.0 TO 1.8mm
- GROOVE DEPTH WILL CHANGE FROM 0.01 TO 0.035mm AT THE EDGES OF THE WEAR PLATE TO 0.125mm DEPTH AT THE MIDDLE OF THE WEAR PLATE
- GROOVE ANGLES CAN BE BETWEEN 60 AND 160 DEGREES BUT MUST BE THE SAME FOR ALL GROOVES
- GROOVE ANGLES ARE TO BE SYMMETRICAL ABOUT CENTERLINE OF BLOCK
- TRY TO AVOID AS MANY GRAPHITE PLUGS AS POSSIBLE
- GROOVE ANGLE AND SPACING CAN VARY FROM MANUFACTURER TO MANUFACTURER