

# SPRINGS & ACCESSORIES INDEX

PAGE	DATE	SERIES	DESCRIPTION
<a href="#">S-1</a>	01/14/08		Springs & Accessories Index
<a href="#">S-2</a>	04/22/97	–	Compression Springs with Rectangular Section
<a href="#">S-3</a>	10/30/96	S01	Compression Springs with Rectangular Section Coding (Light Load)
<a href="#">S-4</a>	10/30/96	S01	Compression Springs with Rectangular Section Coding (Light Load)
<a href="#">S-5</a>	10/30/96	S01	Compression Springs with Rectangular Section Coding (Light Load)
<a href="#">S-6</a>	10/30/96	S02	Compression Springs with Rectangular Section Coding (Medium Load)
<a href="#">S-7</a>	10/30/96	S02	Compression Springs with Rectangular Section Coding (Medium Load)
<a href="#">S-8</a>	10/30/96	S02	Compression Springs with Rectangular Section Coding (Medium Load)
<a href="#">S-9</a>	10/30/96	S03	Compression Springs with Rectangular Section Coding (Heavy Load)
<a href="#">S-10</a>	10/30/96	S03	Compression Springs with Rectangular Section Coding (Heavy Load)
<a href="#">S-11</a>	10/30/96	S03	Compression Springs with Rectangular Section Coding (Heavy Load)
<a href="#">S-12</a>	10/30/96	S04	Compression Springs with Rectangular Section Coding (Extra Heavy Load)
<a href="#">S-13</a>	10/20/00	S04	Compression Springs with Rectangular Section Coding (Extra Heavy Load)
<a href="#">S-14</a>	10/30/96	S04	Compression Springs with Rectangular Section Coding (Extra Heavy Load)
<a href="#">S-15</a>	04/16/96	S21	Spring Cages
<a href="#">S-16</a>	04/16/97	S21	Spring Cage Coding
<a href="#">S-17</a>	01/14/08	S51	Fiber Belted Rubber Die Springs
<a href="#">S-18</a>	07/01/99	S51	Fiber Belted Rubber Die Springs
<a href="#">S-19</a>	09/17/16	S51, S52 & S80	Fiber Belted Rubber Die Spring Coding
<a href="#">S-20</a>	09/17/16	S51, S52 & S80	Fiber Belted Rubber Die Spring Coding
<a href="#">S-21</a>	09/17/16	S51, S52 & S80	Fiber Belted Rubber Die Spring Coding
<a href="#">S-22</a>	09/17/16	S51, S52 & S80	Fiber Belted Rubber Die Spring Coding
<a href="#">S-23</a>	09/17/16	S51, S52 & S80	Fiber Belted Rubber Die Spring Coding
<a href="#">S-24</a>	09/17/16	S51, S52 & S80	Fiber Belted Rubber Die Spring Coding
<a href="#">S-25</a>	09/17/16	S51, S52 & S80	Fiber Belted Rubber Die Spring Coding
<a href="#">S-26</a>	09/17/16	S51, S52 & S80	Fiber Belted Rubber Die Spring Coding
<a href="#">S-27</a>	09/17/16	S51, S52 & S80	Fiber Belted Rubber Die Spring Coding
<a href="#">S-28</a>	09/17/16	S51, S52 & S80	Fiber Belted Rubber Die Spring Coding
<a href="#">S-29</a>	09/17/16	S51, S52 & S80	Fiber Belted Rubber Die Spring Coding
<a href="#">S-30</a>	04/27/01	S31 thru S34	Spring Plungers
<a href="#">S-31</a>	04/27/01	S31 thru S34	Spring Plungers

# COMPRESSION SPRINGS WITH RECTANGULAR SECTION

## 1. SCOPE.

This standard lists the technical specifications for compression die springs made from generally rectangular or oval shaped wire.

The standard does not attempt to specify the quality of the springs; the specific dimensions of the O.D., I.D., or wire cross-section; the material; or the expected length of life.

The springs are classified into four load ranges: light, medium, heavy and extra heavy. See tables 2 through 5.

Conforms to ISO 10243.

## 2. TECHNICAL SPECIFICATIONS:

See figure 1.

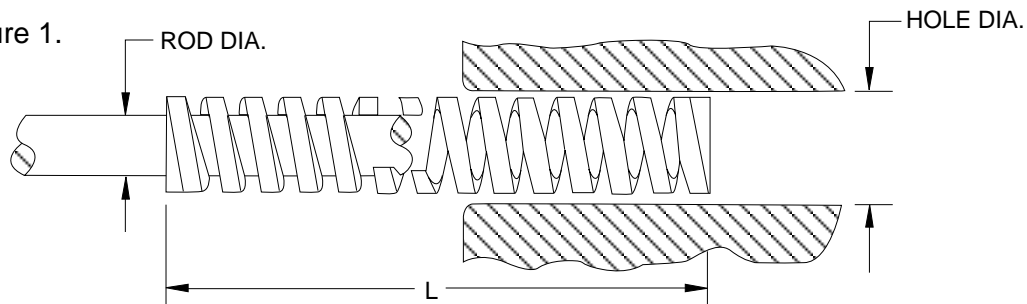

**FIGURE 1**

3. Springs must fit, without binding, into hole sizes and over rod sizes as given in charts.

**TABLE 1 FREE LENGTH TOLERANCE**

L mm	TOLERANCE %
25	± 3%
32	
38	
44	
51	
64	
76	± 2.5%
89	
102	
115	
127	± 2%
139	
152	
178	
203	
254	
305	

*CODING ON FOLLOWING PAGES (S-3 THROUGH S-14)*

# COMPRESSION SPRINGS WITH RECTANGULAR SECTION CODING

(S01 SERIES)

**TABLE 2 – LIGHT LOAD SPRINGS (COLOR CODE: GREEN)**

NAAMS CODE	HOLE DIAMETER H15	ROD DIAMETER h15	FREE LENGTH L	RATE NEWTONS REQ'D. TO DEFLECT 1 mm +/- 10%	MAXIMUM OPERATING DEFLECTION
S011025	10.0	5.0	25	10.0	10.3
S011032			32	8.5	13.1
S011038			38	6.8	15.6
S011044			44	6.0	18.0
S011051			51	5.0	20.9
S011064			64	4.3	26.0
S011076			76	3.2	31.2
S011030			305	1.1	125.0
S011225	12.5	6.3	25	17.9	10.3
S011232			32	16.4	13.1
S011238			38	13.6	15.6
S011244			44	12.1	18.0
S011251			51	11.4	20.9
S011264			64	9.3	26.3
S011276			76	7.1	31.2
S011289			89	5.4	36.5
S011230	305	1.4	125.0		
S011625	16.0	8.0	25	23.4	10.3
S011632			32	22.9	13.1
S011638			38	19.3	15.6
S011644			44	17.1	18.0
S011651			51	15.7	20.9
S011664			64	10.7	26.3
S011676			76	10.0	31.2
S011689			89	8.6	36.5
S011610			102	7.8	41.8
S011630			305	2.5	125.0
S012025	20.0	10.0	25	55.8	10.2
S012032			32	45.0	12.5
S012038			38	33.3	15.0
S012044			44	30.0	18.0
S012051			51	24.5	20.0
S012064			64	20.0	25.0
S012076			76	16.0	30.0
S012089			89	14.0	35.0
S012010			102	12.0	41.0
S012011			115	10.9	46.0
S012012			127	9.5	51.0
S012013			139	8.4	56.0
S012015			152	7.5	61.0
S012030			305	4.0	122.0

# COMPRESSION SPRINGS WITH RECTANGULAR SECTION CODING

(S01 SERIES)

**TABLE 2 – LIGHT LOAD SPRINGS (CON'T.) (COLOR CODE: GREEN)**

NAAMS CODE	HOLE DIAMETER H15	ROD DIAMETER h15	FREE LENGTH L	RATE NEWTONS REQ'D. TO DEFLECT 1 mm +/- 10%	MAXIMUM OPERATING DEFLECTION
S012525	25.0	12.5	25	100.0	10.2
S012532			32	80.3	12.5
S012538			38	62.0	15.0
S012544			44	52.9	18.0
S012551			51	44.0	20.0
S012564			64	35.2	25.0
S012576			76	28.0	30.0
S012589			89	24.0	35.0
S012510			102	21.1	41.0
S012511			115	18.7	46.0
S012512			127	16.7	51.0
S012513			139	15.3	56.0
S012515			152	14.0	61.0
S012517			178	12.5	71.0
S012520			203	10.4	81.0
S012530			305	7.0	122.0
S013238	32.0	16.0	38	94.0	15.0
S013244			44	79.5	18.0
S013251			51	67.0	20.0
S013264			64	53.0	25.0
S013276			76	44.0	30.0
S013289			89	37.2	35.0
S013210			102	32.0	41.0
S013211			115	29.0	46.0
S013212			127	25.0	51.0
S013213			139	23.0	56.0
S013215			152	21.5	61.0
S013217			178	18.2	71.0
S013220			203	15.8	81.0
S013225			254	12.5	102.0
S013230			305	10.3	122.0
S014051			40.0	20.0	51
S014064	64	73.0			25.0
S014076	76	63.0			30.0
S014089	89	51.0			35.0
S014010	102	43.0			41.0
S014011	115	39.6			46.0
S014012	127	37.0			51.0
S014013	139	32.0			56.0
S014015	152	28.0			61.0
S014017	178	25.2			71.0
S014020	203	22.7			81.0
S014025	254	17.0			102.0
S014030	305	14.8			122.0

# COMPRESSION SPRINGS WITH RECTANGULAR SECTION CODING

(S01 SERIES)



Stamping

10/30/96

**TABLE 2 – LIGHT LOAD SPRINGS (CON'T.) (COLOR CODE: GREEN)**

NAAMS CODE	HOLE DIAMETER H15	ROD DIAMETER h15	FREE LENGTH L	RATE NEWTONS REQ'D. TO DEFLECT 1 mm +/- 10%	MAXIMUM OPERATING DEFLECTION		
S015064	50.0	25.0	64	156.0	25.0		
S015076			76	125.0	30.0		
S015089			89	109.0	35.0		
S015010			102	94.0	41.0		
S015011			115	81.0	46.0		
S015012			127	71.0	51.0		
S015013			139	66.5	56.0		
S015015			152	60.0	61.0		
S015017			178	52.0	71.0		
S015020			203	44.0	81.0		
S015025			254	35.0	102.0		
S015030			305	28.5	122.0		
S016376			63.0	38.0	76	189.0	30.0
S016389					89	158.0	35.0
S016310	102	131.0			41.0		
S016311	115	116.0			46.0		
S016312	127	103.0			51.0		
S016315	152	84.3			61.0		
S016317	178	71.5			71.0		
S016320	203	61.7			81.0		
S016325	254	47.0			102.0		
S016330	305	38.2			122.0		

# COMPRESSION SPRINGS WITH RECTANGULAR SECTION CODING

(S02 SERIES)

Stamping

10/30/96

**TABLE 3 – MEDIUM LOAD SPRINGS (COLOR CODE: BLUE)**

NAAMS CODE	HOLE DIAMETER H15	ROD DIAMETER h15	FREE LENGTH L	RATE NEWTONS REQ'D. TO DEFLECT 1 mm +/- 10%	MAXIMUM OPERATING DEFLECTION
S021025	10.0	5.0	25	16.0	9.5
S021032			32	13.0	12.2
S021038			38	11.9	14.4
S021044			44	10.3	16.7
S021051			51	8.9	19.4
S021064			64	7.5	24.3
S021076			76	5.3	28.9
S021030			305	1.6	116.0
S021225	12.5	6.3	25	30.0	9.5
S021232			32	24.8	12.2
S021238			38	21.4	14.4
S021244			44	18.5	16.7
S021251			51	15.5	19.4
S021264			64	12.1	24.3
S021276			76	10.2	28.9
S021289			89	8.4	33.8
S021230	305	2.1	116.0		
S021625	16.0	8.0	25	49.4	9.5
S021632			32	37.1	12.2
S021638			38	33.9	14.4
S021644			44	30.0	16.7
S021651			51	26.4	19.4
S021664			64	20.5	24.3
S021676			76	17.8	28.9
S021689			89	15.2	33.8
S021610			102	13.5	38.8
S021630			305	4.8	116.0
S022025	20.0	10.0	25	98.0	9.4
S022032			32	72.6	12.0
S022038			38	56.0	14.0
S022044			44	47.5	16.5
S022051			51	41.7	19.0
S022064			64	32.3	24.0
S022076			76	25.1	28.0
S022089			89	22.0	33.0
S022010			102	19.8	38.0
S022011			115	18.1	43.0
S022012			127	16.6	48.0
S022013			139	15.1	52.0
S022015			152	13.2	57.0
S022030			305	6.1	114.0

# COMPRESSION SPRINGS WITH RECTANGULAR SECTION CODING

(S02 SERIES)

**TABLE 3 – MEDIUM LOAD SPRINGS (CON'T) (COLOR CODE: BLUE)**

NAAMS CODE	HOLE DIAMETER H15	ROD DIAMETER h15	FREE LENGTH L	RATE NEWTONS REQ'D. TO DEFLECT 1 mm +/- 10%	MAXIMUM OPERATING DEFLECTION
S022525	25.0	12.5	25	147.0	9.4
S022532			32	118.0	12.0
S022538			38	93.0	14.0
S022544			44	80.8	16.5
S022551			51	68.6	19.0
S022564			64	53.0	24.0
S022576			76	43.2	28.0
S022589			89	38.2	33.0
S022510			102	33.0	38.0
S022511			115	28.0	43.0
S022512			127	25.9	48.0
S022513			139	23.2	52.0
S022515			152	20.8	57.0
S022517			178	17.8	67.0
S022520			203	15.8	76.0
S022530			305	10.2	114.0
S023238	32.0	16.0	38	185.0	14.0
S023244			44	158.0	16.5
S023251			51	134.0	19.0
S023264			64	99.0	24.0
S023276			76	80.5	28.0
S023289			89	69.1	33.0
S023210			102	58.8	38.0
S023211			115	51.5	43.0
S023212			127	44.8	48.0
S023213			139	42.3	52.0
S023215			152	37.8	57.0
S023217			178	32.5	67.0
S023220			203	28.9	76.0
S023225			254	21.4	95.0
S023230			305	18.3	114.0
S024051			40.0	20.0	51
S024064	64	140.0			24.0
S024076	76	108.0			28.0
S024089	89	90.7			33.0
S024010	102	81.0			38.0
S024011	115	71.8			43.0
S024012	127	62.7			48.0
S024013	139	57.5			52.0
S024015	152	51.6			57.0
S024017	178	44.1			67.0
S024020	203	36.7			76.0
S024025	254	30.1			95.0
S024030	305	24.6			114.0

# COMPRESSION SPRINGS WITH RECTANGULAR SECTION CODING

(S02 SERIES)



Stamping

10/30/96

**TABLE 3 – MEDIUM LOAD SPRINGS (CON'T) (COLOR CODE: BLUE)**

NAAMS CODE	HOLE DIAMETER H15	ROD DIAMETER h15	FREE LENGTH L	RATE NEWTONS REQ'D. TO DEFLECT 1 mm +/- 10%	MAXIMUM OPERATING DEFLECTION
S025064	50.0	25.0	64	209.0	24.0
S025076			76	168.0	28.0
S025089			89	140.0	33.0
S025010			102	119.0	38.0
S025011			115	106.0	43.0
S025012			127	97.0	48.0
S025013			139	87.0	52.0
S025015			152	80.0	57.0
S025017			178	69.5	67.0
S025020			203	59.8	76.0
S025022			229	50.9	86.0
S025025			254	43.9	95.0
S025030			305	38.6	114.0
S026376			63.0	38.0	76
S026389	89	260.0			33.0
S026310	102	221.0			38.0
S026311	115	187.0			43.0
S026312	127	168.0			48.0
S026315	152	136.0			57.0
S026317	178	114.0			67.0
S026320	203	100.0			76.0
S026322	229	89.2			86.0
S026325	254	78.4			95.0
S026330	305	64.7			114.0



# COMPRESSION SPRINGS WITH RECTANGULAR SECTION CODING

(S03 SERIES)

Stamping

10/30/96

**TABLE 4 – HEAVY LOAD SPRINGS (COLOR CODE: RED)**

NAAMS CODE	HOLE DIAMETER H15	ROD DIAMETER h15	FREE LENGTH L	RATE NEWTONS REQ'D. TO DEFLECT 1 mm +/- 10%	MAXIMUM OPERATING DEFLECTION
S031025	10.0	5.0	25	22.1	7.5
S031032			32	17.5	9.6
S031038			38	17.1	11.4
S031044			44	15.0	13.2
S031051			51	12.8	15.3
S031064			64	10.7	19.2
S031076			76	7.5	22.8
S031030			305	2.1	91.5
S031225	12.5	6.3	25	42.1	7.5
S031232			32	33.2	9.6
S031238			38	29.3	11.4
S031244			44	24.6	13.2
S031251			51	19.6	15.3
S031264			64	15.0	19.2
S031276			76	13.2	22.8
S031289			89	11.4	26.7
S031230	305	2.8	91.5		
S031625	16.0	8.0	25	75.7	7.5
S031632			32	52.8	9.6
S031638			38	48.5	11.4
S031644			44	42.8	13.2
S031651			51	37.1	15.3
S031664			64	30.3	19.2
S031676			76	25.7	22.8
S031689			89	21.7	26.7
S031610			102	19.3	30.6
S031630			305	7.1	91.5
S032025	20.0	10.0	25	216.0	7.5
S032032			32	168.0	9.6
S032038			38	129.0	11.0
S032044			44	112.0	13.0
S032051			51	94.0	15.0
S032064			64	72.1	19.0
S032076			76	59.7	23.0
S032089			89	50.5	27.0
S032010			102	44.2	31.0
S032011			115	38.4	35.0
S032012			127	34.1	38.0
S032013			139	31.0	42.0
S032015			152	28.2	46.0
S032030			305	15.0	91.0

# COMPRESSION SPRINGS WITH RECTANGULAR SECTION CODING

(S03 SERIES)

**TABLE 4 – HEAVY LOAD SPRINGS (CON'T.) (COLOR CODE: RED)**

NAAMS CODE	HOLE DIAMETER H15	ROD DIAMETER h15	FREE LENGTH L	RATE NEWTONS REQ'D. TO DEFLECT 1 mm +/- 10%	MAXIMUM OPERATING DEFLECTION
S032525	25.0	12.5	25	375.0	7.5
S032532			32	297.0	9.6
S032538			38	219.0	11.0
S032544			44	187.0	13.0
S032551			51	156.0	15.0
S032564			64	123.0	19.0
S032576			76	99.0	23.0
S032589			89	84.0	27.0
S032510			102	73.0	31.0
S032511			115	65.0	35.0
S032512			127	57.7	38.0
S032513			139	52.7	42.0
S032515			152	47.8	46.0
S032517			178	41.0	53.0
S032520			203	35.8	61.0
S032530			305	22.9	91.0
S033238	32.0	16.0	38	388.0	11.0
S033244			44	324.0	13.0
S033251			51	272.0	15.0
S033264			64	212.0	19.0
S033276			76	172.0	23.0
S033289			89	141.0	27.0
S033210			102	122.0	31.0
S033211			115	107.0	35.0
S033212			127	93.0	38.0
S033213			139	86.0	42.0
S033215			152	78.0	46.0
S033217			178	67.2	53.0
S033220			203	59.1	61.0
S033225			254	46.4	76.0
S033230			305	38.0	91.0
S034051			40.0	20.0	51
S034064	64	269.0			19.0
S034076	76	219.0			23.0
S034089	89	190.0			27.0
S034010	102	163.0			31.0
S034011	115	142.0			35.0
S034012	127	128.0			38.0
S034013	139	115.0			42.0
S034015	152	105.0			46.0
S034017	178	89.0			53.0
S034020	203	77.0			61.0
S034025	254	61.0			76.0
S034030	305	51.0			91.0

**COMPRESSION SPRINGS  
WITH RECTANGULAR  
SECTION CODING**  
(S03 SERIES)

**TABLE 4 – HEAVY LOAD SPRINGS (CON'T.) (COLOR CODE: RED)**

NAAMS CODE	HOLE DIAMETER H15	ROD DIAMETER h15	FREE LENGTH L	RATE NEWTONS REQ'D. TO DEFLECT 1 mm +/- 10%	MAXIMUM OPERATING DEFLECTION
S035064	50.0	25.0	64	413.0	19.0
S035076			76	339.0	23.0
S035089			89	288.0	27.0
S035010			102	245.0	31.0
S035011			115	215.0	35.0
S035012			127	192.0	38.0
S035013			139	168.0	42.0
S035015			152	154.0	46.0
S035017			178	134.0	53.0
S035020			203	117.0	61.0
S035025			254	89.0	76.0
S035030			305	73.0	91.0

# COMPRESSION SPRINGS WITH RECTANGULAR SECTION CODING

(S04 SERIES)

Stamping

10/30/96

**TABLE 5 – EXTRA HEAVY LOAD SPRINGS (COLOR CODE: YELLOW)**

NAAMS CODE	HOLE DIAMETER H15	ROD DIAMETER h15	FREE LENGTH L	RATE NEWTONS REQ'D. TO DEFLECT 1 mm +/- 10%	MAXIMUM OPERATING DEFLECTION
S041025	10.0	5.0	25	36.8	6.2
S041032			32	27.9	8.0
S041038			38	23.7	9.5
S041044			44	19.2	11.0
S041051			51	16.5	13.0
S041064			64	13.2	16.0
S041076			76	10.9	19.0
S041030			305	2.6	76.0
S041225	12.5	6.3	25	58.5	6.2
S041232			32	43.9	8.0
S041238			38	36.0	9.5
S041244			44	30.3	11.0
S041251			51	26.2	13.0
S041264			64	21.2	16.0
S041276			76	17.1	19.0
S041289			89	14.5	22.0
S041230	305	4.3	76.0		
S041625	16.0	8.0	25	118.0	6.2
S041632			32	89.0	8.0
S041638			38	72.1	9.5
S041644			44	60.9	11.0
S041651			51	52.3	13.0
S041664			64	41.2	16.0
S041676			76	34.1	19.0
S041689			89	29.5	22.0
S041610			102	25.8	26.0
S041630			305	8.4	76.0
S042025	20.0	10.0	25	293.0	6.2
S042032			32	224.0	8.0
S042038			38	177.0	9.5
S042044			44	149.0	11.0
S042051			51	128.0	13.0
S042064			64	99.0	16.0
S042076			76	81.7	19.0
S042089			89	69.5	22.0
S042010			102	60.6	26.0
S042011			115	53.0	29.0
S042012			127	47.5	32.0
S042013			139	43.0	35.0
S042015			152	39.0	38.0
S042030			305	21.2	76.0

# COMPRESSION SPRINGS WITH RECTANGULAR SECTION CODING

(S04 SERIES)

**TABLE 5 – EXTRA HEAVY LOAD SPRINGS (CON'T) (COLOR CODE: YELLOW)**

NAAMS CODE	HOLE DIAMETER H15	ROD DIAMETER h15	FREE LENGTH L	RATE NEWTONS REQ'D. TO DEFLECT 1 mm +/- 10%	MAXIMUM OPERATING DEFLECTION
S042532	25.0	12.5	32	374.4	8.0
S042538			38	294.6*	9.5
S042544			44	244.0	11.0
S042551			51	207.5	13.0
S042564			64	161.0	16.0
S042576			76	130.8	19.0
S042589			89	110.5	22.0
S042510			102	96.3	26.0
S042511			115	85.7	29.0
S042512			127	76.3	32.0
S042515			152	63.5	38.0
S042517			178	53.9	44.0
S042520			203	47.0	51.0
S042530			305	30.9	76.0
S043238			32.0	16.0	38
S043244	44	424.4			11.0
S043251	51	353.0			13.0
S043264	64	269.2			16.0
S043276	76	218.5			19.0
S043289	89	180.3			22.0
S043210	102	155.0			26.0
S043211	115	140.0			29.0
S043212	127	124.0			32.0
S043215	152	102.0			38.0
S043217	178	88.2			44.0
S043220	203	76.0			51.0
S043225	254	60.8			64.0
S043230	305	49.0			76.0
S044051	40.0	20.0			51
S044064			64	487.0	16.0
S044076			76	379.0	19.0
S044089			89	321.0	22.0
S044010			102	281.0	26.0
S044011			115	245.0	29.0
S044012			127	221.0	32.0
S044015			152	168.0	38.0
S044020			203	132.0	51.0
S044025			254	107.0	64.0
S044030			305	87.8	76.0

\* DOES NOT CONFORM TO ISO

A

**COMPRESSION SPRINGS  
WITH RECTANGULAR  
SECTION CODING**  
(S04 SERIES)

**TABLE 5 – EXTRA HEAVY LOAD SPRINGS (CON'T) (COLOR CODE: YELLOW)**

NAAMS CODE	HOLE DIAMETER H15	ROD DIAMETER h15	FREE LENGTH L	RATE NEWTONS REQ'D. TO DEFLECT 1 mm +/- 10%	MAXIMUM OPERATING DEFLECTION
S045064	50.0	25.0	64	709.0	16.0
S045076			76	572.0	19.0
S045089			89	475.0	22.0
S045010			102	405.0	26.0
S045011			115	352.0	29.0
S045012			127	316.0	32.0
S045015			152	239.0	38.0
S045020			203	187.0	51.0
S045025			254	153.0	64.0
S045030			305	127.0	76.0

# SPRING CAGES

(S21 SERIES)

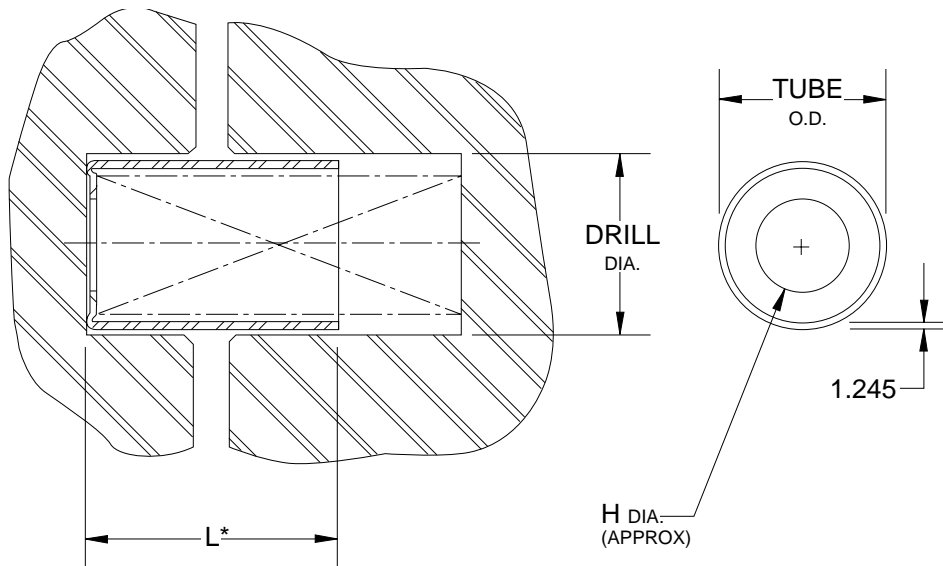

\*L DIMENSION ON FOLLOWING PAGE

NOM. SPRING SIZE $\emptyset$	RECOMMENDED DRILL $\emptyset$	TUBE O.D.	H DIA.
20	24	21.7	11
25	30	28.0	14
32	36	34.4	19
40	43	40.8	25
50	56	53.4	35

**NOTES & SPECIFICATIONS:**

Material, case hardened steel

*CODING ON FOLLOWING PAGE*

# SPRING CAGE CODING

(S21 SERIES)



Stamping

04/16/96

## NAAMS CODES

NAAMS CODE	L	NOM. SPRING SIZE Ø
S212025	25	20
S212032	32	
S212038	38	
S212044	44	
S212051	51	
S212064	64	
S212076	76	
S212089	89	
S212010	102	
S212012	127	
S212015	152	
S212017	178	
S212020	203	
S212022	229	
S212525	25	25
S212532	32	
S212538	38	
S212544	44	
S212551	51	
S212564	64	
S212576	76	
S212589	89	
S212510	102	
S212512	127	
S212515	152	
S212517	178	
S212520	203	
S212522	229	

NAAMS CODE	L	NOM. SPRING SIZE Ø
S213225	25	32
S213232	32	
S213238	38	
S213244	44	
S213251	51	
S213264	64	
S213276	76	
S213289	89	
S213210	102	
S213212	127	
S213215	152	
S213217	178	
S213220	203	
S213222	229	
S214025	25	40
S214032	32	
S214038	38	
S214044	44	
S214051	51	
S214064	64	
S214076	76	
S214089	89	
S214010	102	
S214012	127	
S214015	152	
S214017	178	
S214020	203	
S214022	229	

NAAMS CODE	L	NOM. SPRING SIZE Ø
S215025	25	50
S215032	32	
S215038	38	
S215044	44	
S215051	51	
S215064	64	
S215076	76	
S215089	89	
S215010	102	
S215012	127	
S215015	152	
S215017	178	
S215020	203	
S215022	229	



# FIBER BELTED RUBBER DIE SPRINGS

(S51 SERIES)

Stamping

01/14/08

O.D.	⊥
30	0.5
40	
50	
63	
80	0.8
100	
125	
150	

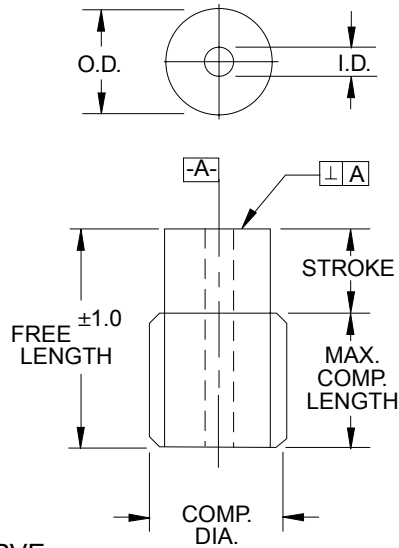

BULGE CURVE

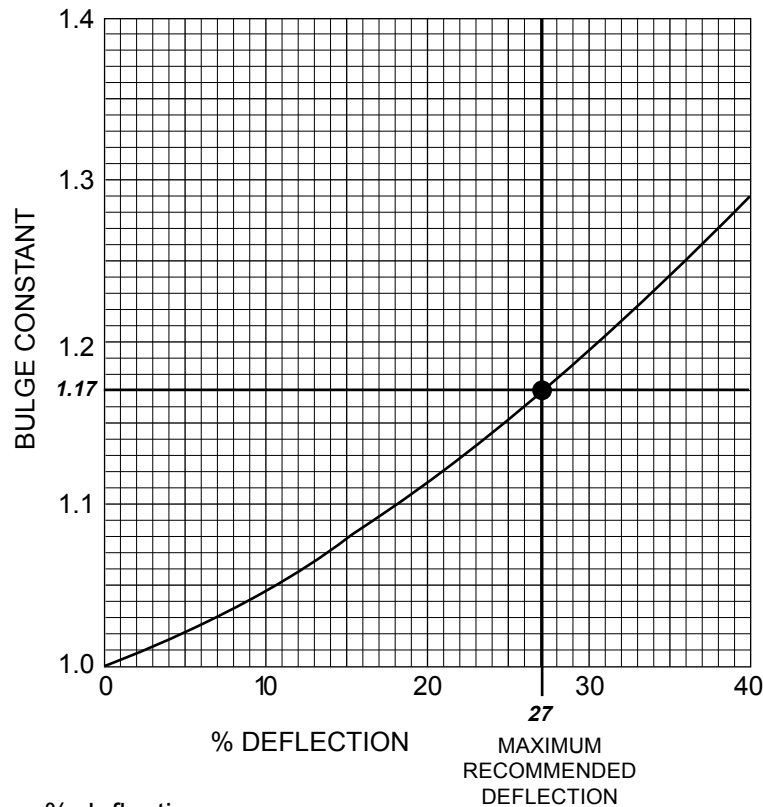

### To Use Chart:

1. Find maximum % deflection.
2. Read up to curve and over to bulge constant.
3. Multiply nominal O.D. by bulge constant to find O.D. at maximum stroke.

### Example: 150 mm Spring @ 25% Compression

1. Find 25% deflection.
2. Read bulge constant at 1.15
3. Multiply 150 x 1.15 = 172 maximum diameter.

A

B

# FIBER BELTED RUBBER DIE SPRINGS

(S51 SERIES)

# CYCLES	HEIGHT	% SET
3	99.0	0.9%
250,000	94.2	5.8%
500,000	92.9	7.1%
1,000,000	91.3	8.7%
1,600,000	90.0	9.1%

40 O.D. x 16 I.D. x 100 mm LG. FIBER BELTED RUBBER DIE SPRING

Compression Set (Height Loss) equals:  $100 - 91.3 = 8.7$  Approx. equals 9%  
 after 1,000,000 cycles at 30% compression @ 100 CPM)

## SAMPLE DIAGRAM

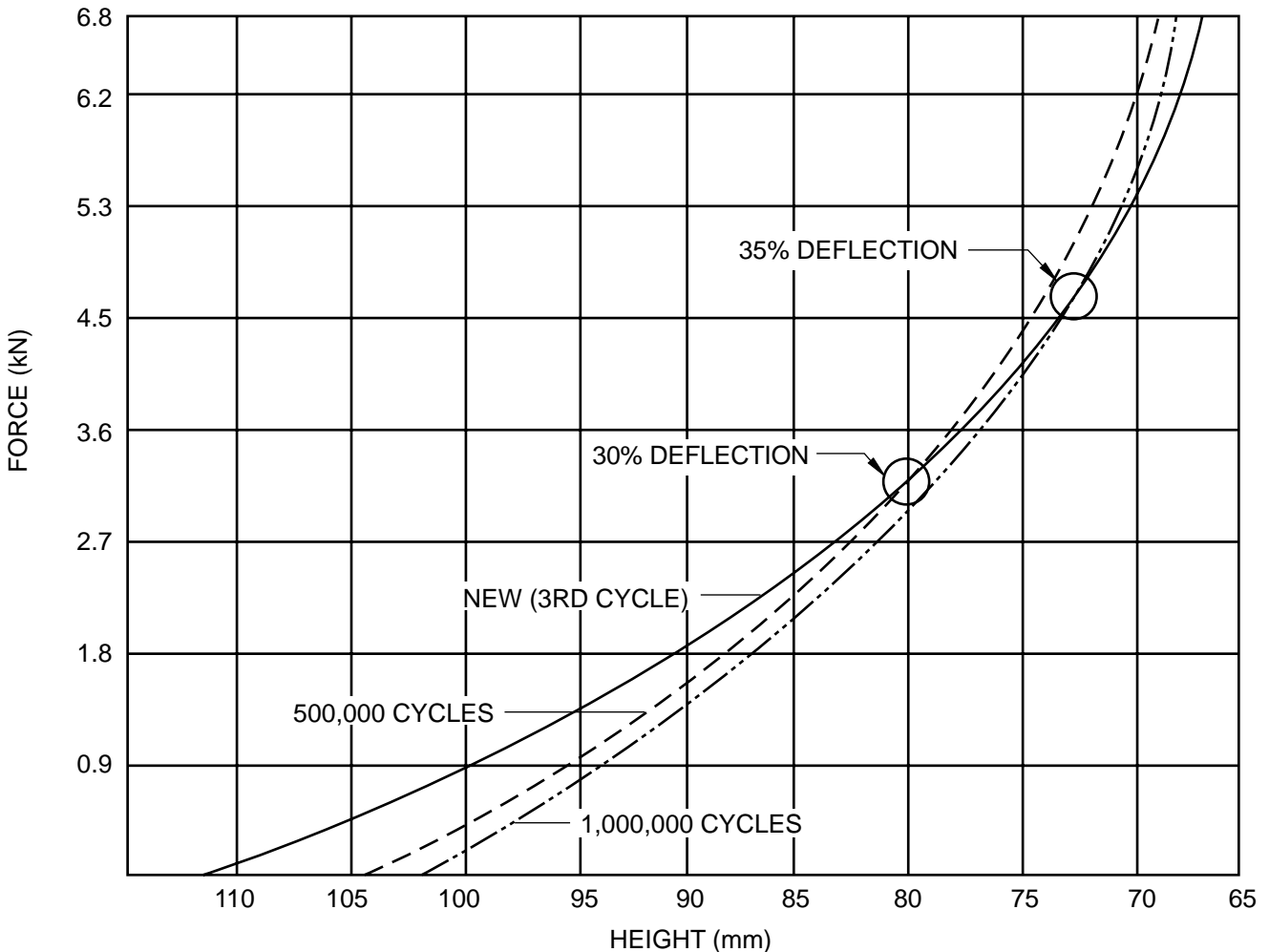

A

# FIBER BELTED RUBBER DIE SPRING CODING

(S51, S52 & S80 SERIES)

GLOBAL STANDARD COMPONENTS



Stamping

09/17/16

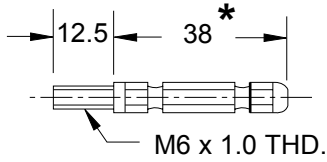

**30 O.D. x 8 I.D.**

Springs furnished with and without studs.

Studs may be ordered separately by NAAMS code.

<b>NAAMS CODE</b>
<b>MOUNTING STUD</b>
S800608

NAAMS CODE W/O STUD	NAAMS CODE WITH STUD	O.D.	I.D.	FREE LENGTH	MAX. OPERATING COMP. (27.5)	MAX. COMP. DIA. (@MAX. COMP.)
S513032	S523032	30	8	32	9	38
S513040	S523040			40	11	
S513050	S523050			50	14	
S513063	S523063			63	17	
S513080	S523080			80	22	

## FORCE REQUIREMENTS FOR RUBBER DIE SPRINGS

30 mm O.D. Rubber Die Springs				
Force (N) required to compress spring				
STROKE	FREE LENGTH			
	32	40	50	63
5	730	570	500	420
10		1,400	1,000	750
15		2,400	1,800	1,300
20			3,300	

Grey areas are not recommended.

Recommendations based on:

$1.2 \leq FL/D \leq 1.7$ ; Deflection  $\leq .275 FL$

### NOTES & SPECIFICATIONS:

Mounting stud length must be accommodated by the designer.

- \* Stud body length must not exceed 50% of spring free length.  
Dimension shown is max.

A

B

C

# FIBER BELTED RUBBER DIE SPRING CODING

(S51, S52 & S80 SERIES)

GLOBAL STANDARD COMPONENTS



Stamping

09/17/16

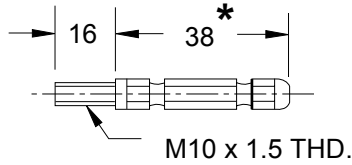

**40 O.D. x 16 I.D.**

Springs furnished with or without studs.

Studs may be ordered separately by NAAMS code.

<b>NAAMS CODE</b>
<b>MOUNTING STUD</b>
S801016

NAAMS CODE W/O STUD	NAAMS CODE WITH STUD	O.D.	I.D.	FREE LENGTH	MAX. OPERATING COMP. (27.5)	MAX. COMP. DIA. (@MAX. COMP.)
S514032	S524032	40	16	32	9	50
S514040	S524040			40	11	
S514050	S524050			50	14	
S514063	S524063			63	17	
S514080	S524080			80	22	
S514010	S524010			100	27	

## FORCE REQUIREMENTS FOR RUBBER DIE SPRINGS

40 mm O.D. Rubber Die Springs Force (N) required to compress spring				
STROKE	FREE LENGTH			
	40	50	60	80
5	850	610	450	370
10	2,000	1,700	1,200	850
15		3,300	2,200	1,500
20		7,000	3,700	2,000

Grey areas are not recommended.  
Recommendations based on:  
 $1.2 \leq FL/D \leq 1.7$ ; Deflection  $\leq .275 FL$

### NOTES & SPECIFICATIONS:

- Mounting stud length must be accommodated by the designer.
- \* Stud body length must not exceed 50% of spring free length.  
Dimension shown is max.

A

B

C

# FIBER BELTED RUBBER DIE SPRING CODING

(S51, S52 & S80 SERIES)

GLOBAL STANDARD COMPONENTS



Stamping

09/17/16

## 50 O.D. x 20 I.D.

Springs furnished with or without studs.

Studs may be ordered separately by NAAMS code.

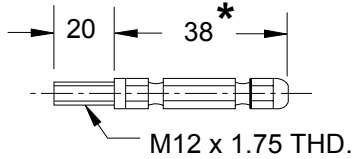

<b>NAAMS CODE</b>
MOUNTING STUD
S801220

NAAMS CODE W/O STUD	NAAMS CODE WITH STUD	O.D.	I.D.	FREE LENGTH	MAX. OPERATING COMP. (27.5)	MAX. COMP. DIA. (@MAX. COMP.)
S515032	S525032	50	20	32	9	64
S515040	S525040			40	11	
S515050	S525050			50	14	
S515063	S525063			63	17	
S515080	S525080			80	22	
S515010	S525010			100	27	
S515012	S525012			125	34	

### FORCE REQUIREMENTS FOR RUBBER DIE SPRINGS

50 mm O.D. Rubber Die Springs Force (N) required to compress spring				
STROKE	FREE LENGTH			
	50	63	80	100
5	860	540	450	320
10	2,500	1,800	1,200	860
15	4,900	3,300	2,300	1,600
20		5,400	3,500	2,500
25			5,300	3,500
30				4,900

Grey areas are not recommended.

Recommendations based on:

$1.2 \leq FL/D \leq 1.75$ ; Deflection  $\leq .275 FL$

#### NOTES & SPECIFICATIONS:

Mounting stud length must be accommodated by the designer.

\* Stud body length must not exceed 50% of spring free length.

Dimension shown is max.

A

B

C

# FIBER BELTED RUBBER DIE SPRING CODING

(S51, S52 & S80 SERIES)

GLOBAL STANDARD COMPONENTS



Stamping

09/17/16

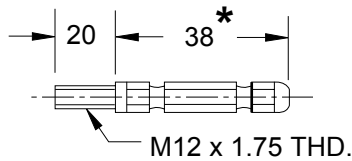

<b>NAAMS CODE</b>
MOUNTING STUD
S801220

## 63 O.D. x 20 I.D.

Springs furnished with or without studs.

Studs may be ordered separately by NAAMS code.

NAAMS CODE W/O STUD	NAAMS CODE WITH STUD	O.D.	I.D.	FREE LENGTH	MAX. OPERATING COMP. (27.5)	MAX. COMP. DIA. (@MAX. COMP.)
S516340	S526340	63	20	40	11	79
S516350	S526350			50	14	
S516363	S526363			63	17	
S516380	S526380			80	22	
S516310	S526310			100	27	
S516312	S526312			125	34	
S516315	S526315			150	41	

A

### FORCE REQUIREMENTS FOR RUBBER DIE SPRINGS

63 mm O.D. Rubber Die Springs				
Force (N) required to compress spring				
STROKE	FREE LENGTH			
	63	80	100	125
5	1,400	1,100	880	650
10	3,700	2,600	2,000	1,500
15	6,400	4,600	3,500	2,300
20		7,100	5,000	3,700
25		10,000	7,100	5,000
30			9,600	6,900
35			12,500	9,000

B

C

Grey areas are not recommended.  
Recommendations based on:  
 $1.2 \leq FL/D \leq 1.75$ ; Deflection  $\leq .275 FL$

#### NOTES & SPECIFICATIONS:

- Mounting stud length must be accommodated by the designer.
- \* Stud body length must not exceed 50% of spring free length.  
Dimension shown is max.

# FIBER BELTED RUBBER DIE SPRING CODING

(S51, S52 & S80 SERIES)

GLOBAL STANDARD COMPONENTS



Stamping

09/17/16

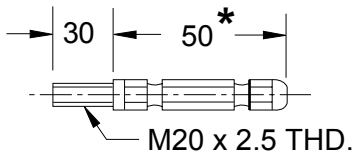

**80 O.D. x 25 I.D.**

Springs furnished with or without studs.

Studs may be ordered separately by NAAMS code.

<b>NAAMS CODE</b>
<b>MOUNTING STUD</b>
S802025

NAAMS CODE W/O STUD	NAAMS CODE WITH STUD	O.D.	I.D.	FREE LENGTH	MAX. OPERATING COMP. (27.5)	MAX. COMP. DIA. (@MAX. COMP.)
S518063	S528063	80	25	63	17	104
S518080	S528080			80	22	
S518010	S528010			100	27	
S518012	S528012			125	34	
S518014	S528014			140	38	
S518015	S528015			150	41	
S518016	S528016			160	44	
S518018	S528018			180	50	

A

## FORCE REQUIREMENTS FOR RUBBER DIE SPRINGS

80 mm O.D. Rubber Die Springs Force (N) required to compress spring					
STROKE	FREE LENGTH				
	80	100	125	140	150
5	2,200	1,900	1,250	1,100	1,050
10	4,400	3,800	2,500	2,200	2,100
15	8,050	6,200	4,500	3,950	3,550
20	11,700	8,600	6,500	5,700	5,000
25		12,500	8,750	7,400	6,800
30		15,000	11,000	9,100	8,600
35		23,450	14,050	11,400	10,500
40			17,100	13,700	12,400
45				17,350	15,300

Grey areas are not recommended.

Recommendations based on:

$1.2 \leq FL/D \leq 1.75$ ; Deflection  $\leq .275 FL$

B

C

### NOTES & SPECIFICATIONS:

Mounting stud length must be accommodated by the designer.

\* Stud body length must not exceed 50% of spring free length.

Dimension shown is max.

# FIBER BELTED RUBBER DIE SPRING CODING

(S51, S52 & S80 SERIES)

GLOBAL STANDARD COMPONENTS



Stamping

09/17/16

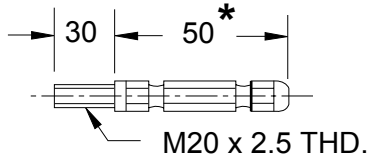

**100 O.D. x 25 I.D.**

Springs furnished with or without studs.

Studs may be ordered separately by NAAMS code.

<b>NAAMS CODE</b>
<b>MOUNTING STUD</b>
S802025

NAAMS CODE W/O STUD	NAAMS CODE WITH STUD	O.D.	I.D.	FREE LENGTH	MAX. OPERATING COMP. (27.5)	MAX. COMP. DIA. (@MAX. COMP.)
S511063	S521063	100	25	63	17	128
S511080	S521080			80	22	
S511090	S521090			90	24	
S511010	S521010			100	27	
S511012	S521012			125	34	
S511014	S521014			140	38	
S511015	S521015			150	41	
S511016	S521016			160	44	
S511018	S521018			180	50	
S511019	S521019			190	52	
S511020	S521020			200	55	

A

CONTINUED ON FOLLOWING PAGE

**NOTES & SPECIFICATIONS:**

Mounting stud length must be accommodated by the designer.

- \* Stud body length must not exceed 50% of spring free length.  
Dimension shown is max.



# FIBER BELTED RUBBER DIE SPRING CODING

(S51, S52 & S80 SERIES)

GLOBAL STANDARD COMPONENTS



Stamping

09/17/16

## FORCE REQUIREMENTS FOR RUBBER DIE SPRINGS

100 mm O.D. Rubber Die Springs Force (N) required to compress spring						
STROKE	FREE LENGTH					
	100	125	140	150	160	180
5	2,750	2,150	1,700	1,600	1,300	1,150
10	5,500	4,300	3,400	3,200	2,600	2,300
15	9,700	7,250	6,300	5,950	5,150	4,450
20	13,900	10,200	9,200	8,700	7,700	6,600
25	19,400	14,050	12,200	11,300	10,100	8,800
30	24,900	17,900	15,200	13,900	12,500	11,000
35		22,950	18,900	17,400	15,750	13,750
40		28,000	22,600	20,900	19,000	16,500
45			29,200	25,900	22,750	19,250
50				30,900	26,500	22,000

Grey areas are not recommended.  
Recommendations based on:  
 $1.2 \leq FL/D \leq 1.75$ ; Deflection  $\leq .275 FL$

A  
B

CONTINUED FROM PREVIOUS PAGE

### NOTES & SPECIFICATIONS:

- Mounting stud length must be accommodated by the designer.
- \* Stud body length must not exceed 50% of spring free length.  
Dimension shown is max.

# FIBER BELTED RUBBER DIE SPRING CODING

(S51, S52 & S80 SERIES)

GLOBAL STANDARD COMPONENTS



Stamping

09/17/16

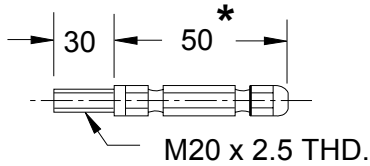

**125 O.D. x 25 I.D.**

Springs furnished with or without studs.

Studs may be ordered separately by NAAMS code.

<b>NAAMS CODE</b>
<b>MOUNTING STUD</b>
S802025

NAAMS CODE W/O STUD	NAAMS CODE WITH STUD	O.D.	I.D.	FREE LENGTH	MAX. OPERATING COMP. (35%)	MAX. COMP. DIA. (@MAX. COMP.)
S511263	S521263	125	25	63	17	161
S511280	S521280			80	22	
S511210	S521210			100	27	
S511212	S521212			125	34	
S511214	S521214			140	38	
S511215	S521215			150	41	
S511216	S521216			160	44	
S511218	S521218			180	50	
S511219	S521219			190	52	
S511220	S521220			200	55	
S511221	S521221			215	59	
S511222	S521222			225	62	

A

CONTINUED ON FOLLOWING PAGE

**NOTES & SPECIFICATIONS:**

- Mounting stud length must be accommodated by the designer.
- \* Stud body length must not exceed 50% of spring free length.  
Dimension shown is max.

# FIBER BELTED RUBBER DIE SPRING CODING

(S51, S52 & S80 SERIES)

GLOBAL STANDARD COMPONENTS



Stamping

09/17/16

## FORCE REQUIREMENTS FOR RUBBER DIE SPRINGS

125 mm O.D. Rubber Die Springs Force (N) required to compress spring								
STROKE	FREE LENGTH							
	140	150	160	180	190	200	215	225
5	3,400	3,000	2,750	2,500	2,250	2,000	1,700	1,400
10	6,800	6,000	5,500	5,000	4,500	4,000	3,500	2,800
15	11,150	10,000	9,350	8,000	7,600	7,250	6,650	5,900
20	15,500	14,000	13,200	11,000	10,700	10,500	9,800	9,000
25	20,350	18,750	17,250	15,000	14,100	13,250	12,400	11,500
30	25,200	23,500	21,300	19,000	17,500	16,000	15,000	14,000
35	32,350	29,000	26,400	23,600	21,350	19,750	18,000	17,000
40	39,500	34,500	31,500	28,200	25,200	23,500	21,000	20,000
45		43,250	38,500	32,600	29,850	27,500	25,000	24,100
50		52,000	45,500	37,000	34,500	31,500	29,000	28,200
55				44,500	41,050	36,750	33,000	31,350
60						42,000	37,000	34,500
65						49,750	43,500	39,750

A

Grey areas are not recommended.  
Recommendations based on:  
 $1.2 \leq FL/D \leq 1.75$ ; Deflection  $\leq .275 FL$

CONTINUED FROM PREVIOUS PAGE

### NOTES & SPECIFICATIONS:

- Mounting stud length must be accommodated by the designer.
- \* Stud body length must not exceed 50% of spring free length.  
Dimension shown is max.

# FIBER BELTED RUBBER DIE SPRING CODING

(S51, S52 & S80 SERIES)

GLOBAL STANDARD COMPONENTS



Stamping

09/17/16

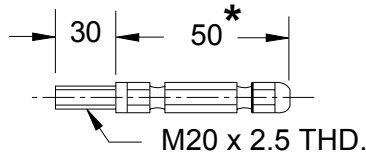

**150 O.D. x 25 I.D.**

Springs furnished with or without studs.

Studs may be ordered separately by NAAMS code.

<b>NAAMS CODE</b>
<b>MOUNTING STUD</b>
S802025

NAAMS CODE W/O STUD	NAAMS CODE WITH STUD	O.D.	I.D.	FREE LENGTH	MAX. OPERATING COMP. (27.5)	MAX. COMP. DIA. (@MAX. COMP.)
S511563	S521563	150	25	63	17	192
S511580	S521580			80	22	
S511510	S521510			100	27	
S511512	S521512			125	34	
S511514	S521514			140	38	
S511515	S521515			150	41	
S511516	S521516			160	44	
S511518	S521518			180	50	
S511519	S521519			190	52	
S511520	S521520			200	55	
S511525	S521525			250	69	

CONTINUED ON FOLLOWING PAGE

**NOTES & SPECIFICATIONS:**

Mounting stud length must be accommodated by the designer.

- \* Stud body length must not exceed 50% of spring free length.  
Dimension shown is max.

# FIBER BELTED RUBBER DIE SPRING CODING

(S51, S52 & S80 SERIES)

GLOBAL STANDARD COMPONENTS



Stamping

09/17/16

## FORCE REQUIREMENTS FOR RUBBER DIE SPRINGS

150 mm O.D. Rubber Die Springs Force (N) required to compress spring					
STROKE	FREE LENGTH				
	160	180	190	200	250
5	5,500	5,000	4,500	4,000	3,500
10	11,000	10,000	9,000	8,000	7,000
15	16,500	15,000	14,000	13,000	11,000
20	22,000	20,000	19,000	18,000	15,000
25	29,500	26,500	25,500	21,500	18,000
30	37,000	33,000	32,000	25,000	21,000
35	46,000	39,500	37,500	32,500	27,000
40	55,000	46,000	43,000	40,000	33,000
45	66,000	53,500	50,500	47,500	36,500
50		61,000	58,000	55,000	40,000
55		76,500	69,500	58,500	46,000
60			81,000	62,000	52,000
65				83,500	58,500
70					65,000
75					73,500
80					82,000

A

Grey areas are not recommended.

Recommendations based on:

$1.2 \leq FL/D \leq 1.75$ ; Deflection  $\leq .275 FL$

CONTINUED FROM PREVIOUS PAGE

### NOTES & SPECIFICATIONS:

Mounting stud length must be accommodated by the designer.

- \* Stud body length must not exceed 50% of spring free length.  
Dimension shown is max.

# SPRING PLUNGERS

(S31, S32 SERIES)

GLOBAL STANDARD COMPONENTS



Stamping

04/27/01

## S31 SERIES

S310XXX CHAMFERED TIP  
S311XXX SPHERICAL TIP

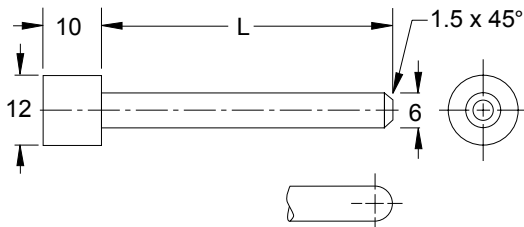

ALTERNATE SPHERICAL TIP

MATERIAL: STEEL

## S32 SERIES

S320XXX CHAMFERED TIP  
S321XXX SPHERICAL TIP

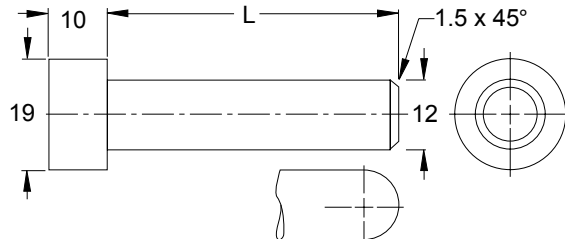

ALTERNATE SPHERICAL TIP

NAAMS CODE		L DIM
S310025	S311025	25
S310030	S311030	30
S310035	S311035	35
S310040	S311040	40
S310045	S311045	45
S310050	S311050	50
S310055	S311055	55
S310060	S311060	60
S310065	S311065	65
S310070	S311070	70
S310075	S311075	75
S310080	S311080	80
S310085	S311085	85
S310090	S311090	90
S310095	S311095	95
S310100	S311100	100
S310105	S311105	105
S310110	S311110	110

NAAMS CODE		L DIM
S310115	S311115	115
S310120	S311120	120
S310125	S311125	125
S310130	S311130	130
S310135	S311135	135
S310140	S311140	140
S310145	S311145	145
S310150	S311150	150
S310155	S311155	155
S310160	S311160	160
S310165	S311165	165
S310170	S311170	170
S310175	S311175	175
S310180	S311180	180
S310185	S311185	185
S310190	S311190	190
S310195	S311195	195
S310200	S311200	200

NAAMS CODE		L DIM
S320050	S321050	50
S320055	S321055	55
S320060	S321060	60
S320065	S321065	65
S320070	S321070	70
S320075	S321075	75
S320080	S321080	80
S320085	S321085	85
S320090	S321090	90
S320095	S321095	95
S320100	S321100	100
S320105	S321105	105
S320110	S321110	110
S320115	S321115	115
S320120	S321120	120
S320125	S321125	125
S320130	S321130	130
S320135	S321135	135
S320140	S321140	140
S320145	S321145	145
S320150	S321150	150
S320155	S321155	155
S320160	S321160	160
S320165	S321165	165
S320170	S321170	170
S320175	S321175	175
S320180	S321180	180
S320185	S321185	185
S320190	S321190	190
S320195	S321195	195
S320200	S321200	200

# SPRING PLUNGERS

(S33, S34 SERIES)

GLOBAL STANDARD COMPONENTS



Stamping

04/27/01

## S33 SERIES

S330XXX CHAMFERED TIP  
S331XXX SPHERICAL TIP

MATERIAL: STEEL

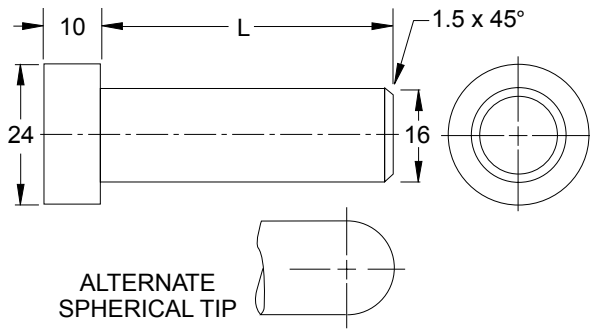

## S34 SERIES

S340XXX CHAMFERED TIP  
S341XXX SPHERICAL TIP

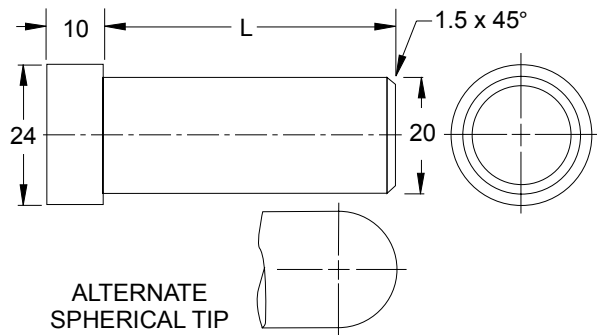

NAAMS CODE	L DIM
S330050	50
S330055	55
S330060	60
S330065	65
S330070	70
S330075	75
S330080	80
S330085	85
S330090	90
S330095	95
S330100	100
S330105	105
S330110	110
S330115	115
S330120	120
S330125	125
S330130	130
S330135	135
S330140	140
S330145	145
S330150	150
S330155	155
S330160	160
S330165	165
S330170	170
S330175	175
S330180	180
S330185	185
S330190	190
S330195	195
S330200	200

NAAMS CODE	L DIM
S340050	50
S340055	55
S340060	60
S340065	65
S340070	70
S340075	75
S340080	80
S340085	85
S340090	90
S340095	95
S340100	100
S340105	105
S340110	110
S340115	115
S340120	120
S340125	125
S340130	130
S340135	135
S340140	140
S340145	145
S340150	150
S340155	155
S340160	160
S340165	165
S340170	170
S340175	175
S340180	180
S340185	185
S340190	190
S340195	195
S340200	200