

# NITROGEN CYLINDERS & COMPONENTS INDEX

PAGE	DATE	SERIES	DESCRIPTION
<a href="#">N-1</a>	06/27/07	-	Nitrogen Cylinders & Components Index
<a href="#">N-2</a>	06/27/07	-	Nitrogen Gas Spring
<a href="#">N-3</a>	07/01/99	-	Nitrogen Gas Spring
<a href="#">N-4</a>	07/01/99	-	Nitrogen Gas Spring
<a href="#">N-5</a>	06/27/07	N03	Nitrogen Gas Spring
<a href="#">N-6</a>	06/27/07	N03	Nitrogen Gas Spring Coding
<a href="#">N-7</a>	06/27/07	N10	Nitrogen Gas Spring Top Flange Mount
<a href="#">N-8</a>	06/27/07	N11	Nitrogen Gas Spring Split Flange Mount
<a href="#">N-9</a>	07/01/99	N12	Nitrogen Gas Spring Bolt-on Base Mount
<a href="#">N-10</a>	06/27/07	N12	Nitrogen Gas Spring Bolt-on Base Mount
<a href="#">N-11</a>	06/27/07	N12	Nitrogen Gas Spring Bolt-on Base Mount (Transferred to P N70)
<a href="#">N-12</a>	06/27/07	N12	Discontinued
<a href="#">N-13</a>	07/01/99	N13	Nitrogen Gas Spring Horizontal Foot Mount - Front
<a href="#">N-14</a>	07/01/99	N14	Nitrogen Gas Spring Horizontal Foot Mount - Rear
<a href="#">N-15</a>	02/16/01	N15	Nitrogen Gas Spring Horizontal Foot Mount - Rear (Keyed) (DISCONTINUED)
<a href="#">N-16</a>	09/10/04	N80 & N81	Miscellaneous Stripper - Gas Spring
<a href="#">N-17</a>	09/10/04	N82–N88	Miscellaneous Stripper - Gas Spring
<a href="#">N-18</a>	09/10/04	---	Open Page
<a href="#">N-19</a>	12/15/00	N90	Nitrogen Gas Spring
<a href="#">N-20</a>	12/15/00	N76	345 Bar Nitrogen Control Panel
<a href="#">N-21</a>	12/15/00	N51	O-Ring Face Style Crimp Hose Fittings
<a href="#">N-22</a>	12/15/00	N52	O-Ring Face Fittings
<a href="#">N-23</a>	12/15/00	N52	O-Ring Face Fittings
<a href="#">N-24</a>	12/15/00	N52	O-Ring Face Fittings
<a href="#">N-25</a>	12/15/00	N91	Nitrogen Gas System

## Guidelines for Nitrogen Gas Springs supplied to NAAMS

### General Guidelines:

- Material, dimensions and design of individual parts such as the piston, cylinder body and cartridge shall be to manufacturer's choice, unless otherwise specified in the guidelines listed on the following pages.
- Gas springs shall be designed, manufactured and tested in accordance with applicable pressure vessel regulations.
- The manufacturer's choice of materials, dimensions, and design shall ensure a safe working product.

### Piston:

- Each piston shall be permanently marked with manufacturer's name and lot number for identification and tracking purposes.
- The piston shall be manufactured with a secondary safety/security feature that will introduce a gas leakage in the event of piston rod breakage.

### Cylinder Body:

- Shall be a one-piece or welded construction
- Shall be permanently marked with the following information:  
Individual serial number for tracking purposes, NAAMS Code, Manufacturer's name or logo, repair kit number and maximum charging pressure.

### Cartridge:

Cartridge design and material specifications are to manufacturer's choice along with the following requirements:

- Shall be designed in such a way that when assembled upside down in the cylinder body and pressurized, the nitrogen will then be exhausted rapidly from the cylinder.
- The bottom shall have a groove or chamfer feature to lock the retaining ring in place if the cartridge is installed upside down.

# NITROGEN GAS SPRING

## Cartridge Retainer Ring:

- Shall be one-piece construction.
- Shall be designed in such a way that it presses outward when installed in the groove.

## Charging Port:

- The charging port is G 1/8 BSPP
- Gas spring shall be shipped with a high pressure needle valve, port plug, and service fitting.
- Spring shall be convertible from a self contained system to a pipe system.

## Labels:

- **Identification Label** shall have manufacturer's name or logo, address, telephone number and NAAMS Code number.
- **Caution/Warning Label** shall be placed directly above the charging port. This label shall contain graphics and/or instructions on proper handling procedures including a specific warning not to attempt any maintenance on the cylinder until all the nitrogen pressure has been discharged. The maximum charging pressure of 150 bar / 2150 PSI shall be on the label. Background of label shall be bright yellow with black lettering.

## NITROGEN GAS SPRING CARTRIDGE AND REPAIR KIT PROCEDURES

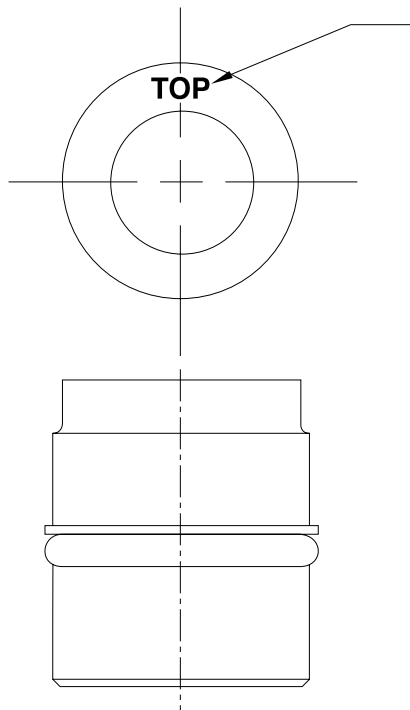

TYPICAL GAS CARTRIDGE

MANUFACTURER SHALL PERMANENTLY MARK  
THE WORD “**TOP**” OR “**THIS END UP**” ON THE  
FACE OF THE CARTRIDGE WHEN PRACTICABLE

OPTIONAL: CARTRIDGE MAY HAVE THE WORDS  
“**TOP**” OR “**THIS END UP**” PERMANENTLY MARKED  
ON THE SIDE WITH AN ARROW POINTING UP

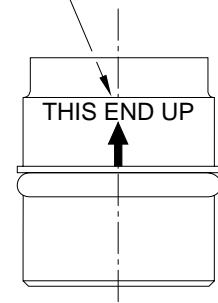

- Repair kits shall contain a set of instructions detailing the proper repair procedure. The instructions shall have illustrations along with schematics and written step-by-step repair procedures.
- Manufacturer's name shall be permanently marked on the side of the cartridge.
- The cartridge bottom shall have a machined groove / chamfer to lock the retaining ring in place if the cartridge is installed upside down.
- The cartridge shall have a fail-safe gas exhaust system built into it that, when assembled upside down and pressurized, the nitrogen will be exhausted rapidly from the cylinder.

# NITROGEN GAS SPRING

(N03 SERIES)

GLOBAL STANDARD COMPONENTS



Stamping

06/27/07

E  
A  
F  
I  
L  
J  
B  
G  
M  
C  
H

D  
K

CONFORMS TO ISO SPECIFICATION 11901-1

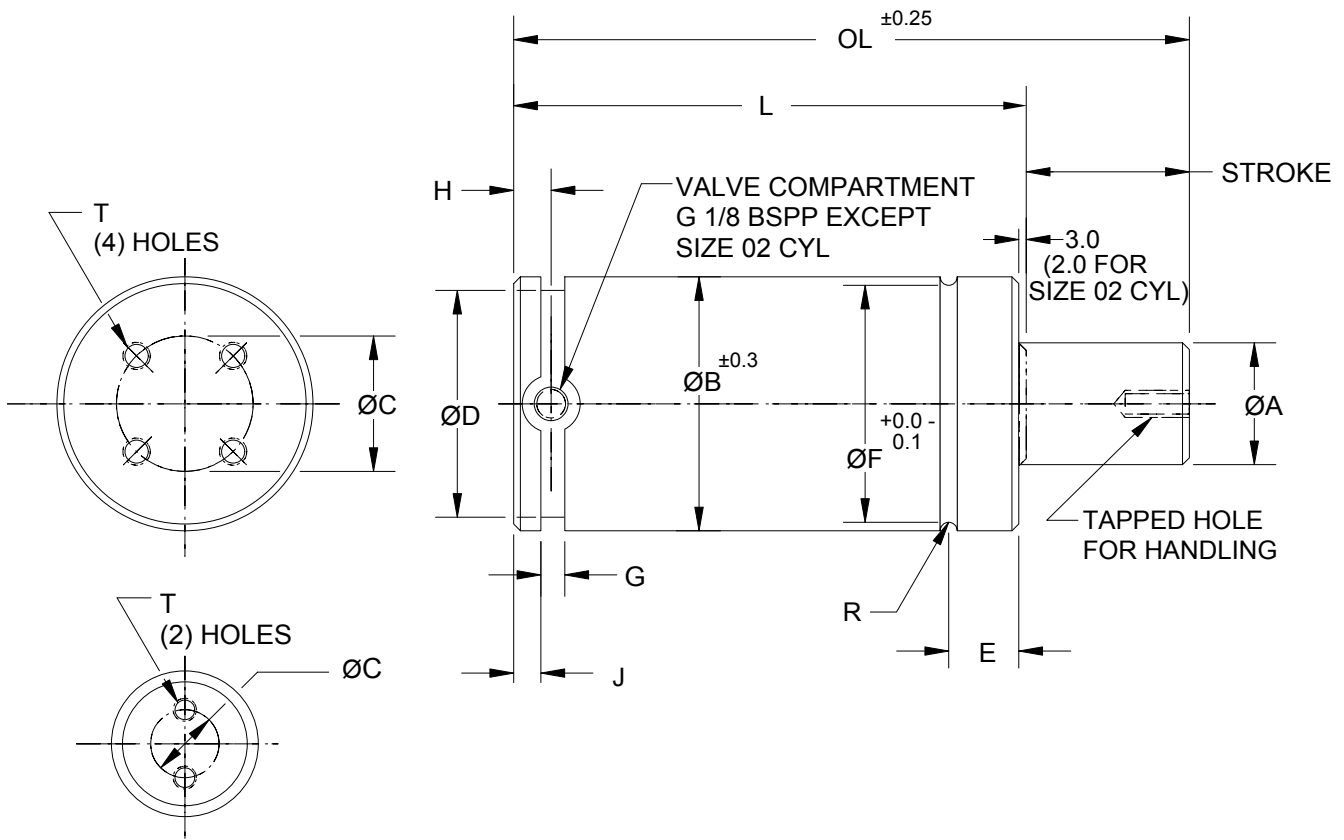

SIZE 02, 07 CYL ONLY

SIZE	SPRING FORCE (kN)	$\varnothing A$	$\varnothing B$	T	$\varnothing C$	$\varnothing D$	E	$\varnothing F$	G MIN	H	J +0.15/-0.00	R
02	2.5	15	38	M6 X 6	25	33	12.5	36	3.5	5.0/6.0	4.0	1.0
07	7.5	25	50	M8 X 13	20	43	14.5	46	5.0	10.0/12.0	8.0	2.0
15	15.0	36	75	M8 X 13	40	67	18.0	70	5.0	10.0/12.0	8.0	2.5
30	30.0	50	95	M8 X 13	60	87	21.0	90	5.0	10.0/12.0	8.0	2.5
50	50.0	65	120	M10 X 16	80	112	22.5	115	5.0	10.0/12.0	8.0	2.5
75	75.0	80	150	M10 X 16	100	142	24.5	145	5.0	10.0/12.0	8.0	2.5
99	100.0	95	195	M12 X 16	120	187	30.9	190	8.0	10.0/12.0	8.0	2.5

CODING ON FOLLOWING PAGE

# NITROGEN GAS SPRING CODING

(N03 SERIES)

GLOBAL STANDARD COMPONENTS



Stamping

06/27/07

E

A

NAAMS CODE	SPRING FORCE (kN)	STROKE	L	OL
N030202	2.5	25	75	100
N030205		50	100	150
N030206		63	113	176
N030208		80	130	210
N030702	7.5	25	120	145
N030703		38	133	171
N030705		50	145	195
N030708		80	175	255
N030710		100	195	295
N030712		125	220	345
N030716		160	255	415
N030720		200	295	495
N031502	15	25	135	160
N031503		38	148	186
N031505		50	160	210
N031508		80	190	270
N031510		100	210	310
N031512		125	235	360
N031516		160	270	430
N031520		200	310	510
N033002	30	25	145	170
N033003		38	158	196
N033005		50	170	220
N033008		80	200	280
N033010		100	220	320
N033012		125	245	370
N033016		160	280	440
N033020		200	320	520
N035002	50	25	165	190
N035003		38	178	216
N035005		50	190	240
N035008		80	220	300
N035010		100	240	340
N035012		125	265	390
N035016		160	300	460
N035020		200	340	540
N037502	75	25	180	205
N037503		38	193	231
N037505		50	205	255
N037508		80	235	315
N037510		100	255	355
N037512		125	280	405
N037516		160	315	475
N037520		200	355	555

NAAMS CODE	SPRING FORCE (kN)	STROKE	L	OL
N039905	100	50	210	260
N039908		80	240	320
N039910		100	260	360
N039912		125	285	410
N039916		160	320	480
N039920		200	360	560

C

F

D

B

# NITROGEN GAS SPRING TOP FLANGE MOUNT

(N10 SERIES)

GLOBAL STANDARD COMPONENTS



Stamping

06/27/07

A

CONFORMS TO ISO SPECIFICATION 11901-2

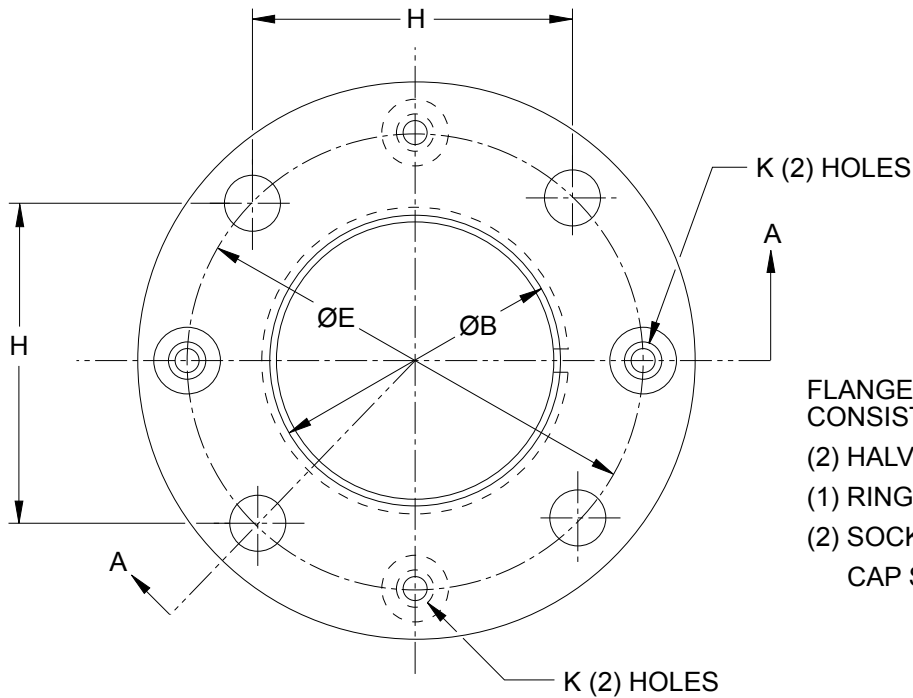

FLANGE MOUNT ASSEMBLY  
CONSISTS OF:  
(2) HALVES  
(1) RING SET  
(2) SOCKET FLAT HEAD  
CAP SCREWS

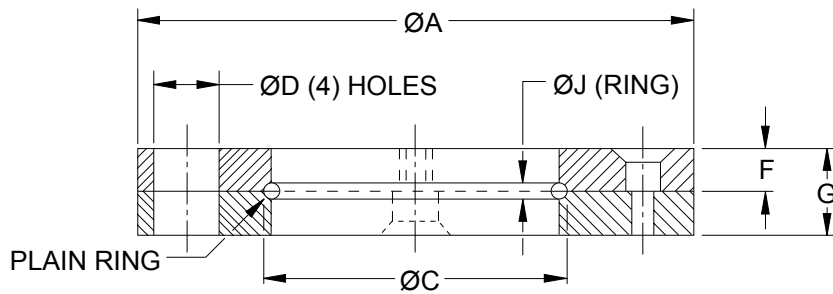

SECTION A-A

NAAMS CODE	SPRING FORCE (kN)	$\text{ØA}$	$\text{ØB} \pm 0.1$	$\text{ØC} +0.1 -0.3$	$\text{ØD}$	$\text{ØE}$	F	G	H	$\text{ØJ h10}$	K
N100200	2.5	68	38.5	40	6.8	56	4.5	9	40.0	2.0	M5
N100700	7.5	95	50.5	54	9	80	6.5	13	56.5	4.0	M6
N101500	15	122	75.5	80	11	104	8.0	16	73.5	5.0	M6
N103000	30	150	95.5	100	13.5	130	9.0	18	92.0	5.0	M6
N105000	50	175	120.5	125	13.5	155	10.5	21	109.5	5.0	M6
N107500	75	220	150.5	155	17.5	194	13.5	27	138.0	5.0	M6

**NOTES & SPECIFICATIONS:**

Material, steel

Tensile strength 490 MPa (71 ksi)

B

# NITROGEN GAS SPRING SPLIT FLANGE MOUNT

(N11 SERIES)

GLOBAL STANDARD COMPONENTS



Stamping

06/27/07

A

CONFORMS TO ISO SPECIFICATION 11901-2

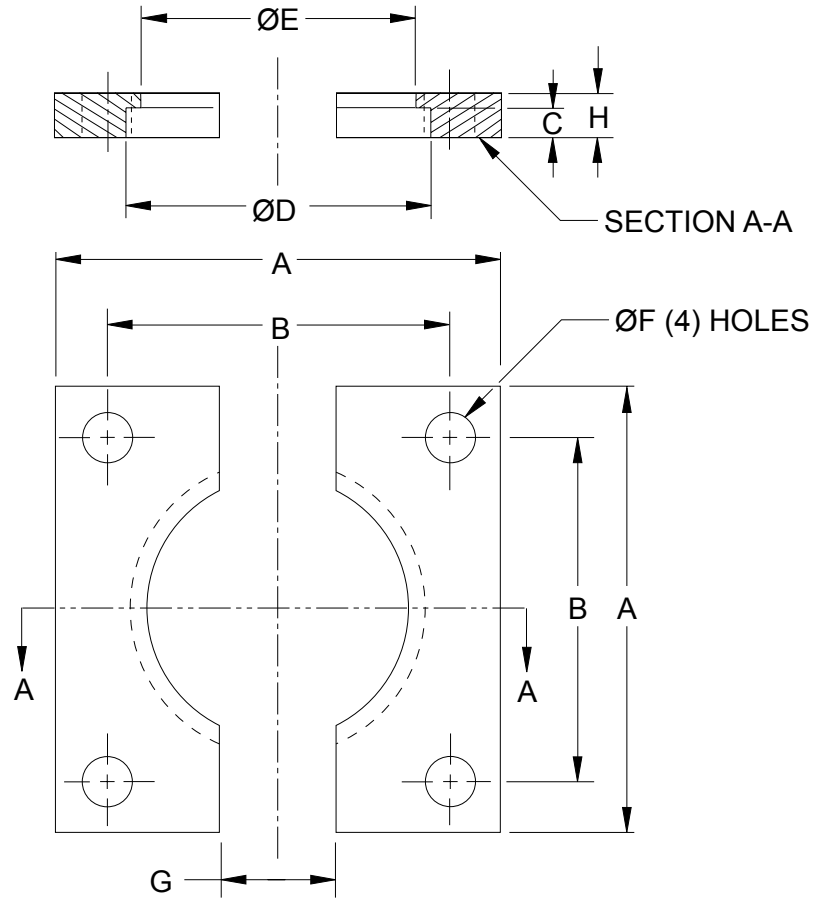

BREAK EDGES

D

NAAMS CODE	SPRING FORCE (kN)	A	B	C +0.0 -0.1	ØD	ØE	ØF	G	H
N110200	2.5	55	40.0	4	38.5	34.5	6.8	5	7
N110700	7.5	75	56.5	8	50.5	44.5	9.0	24	12
N111500	15	100	73.5	8	75.5	68.5	11.0	24	12
N113000	30	120	92.0	8	95.5	88.5	13.5	24	12
N115000	50	140	109.5	8	120.5	113.5	13.5	24	12
N117500	75	190	138.0	8	150.5	143.5	17.5	24	12
N119900	100	210	170.0	8	195.5	188.0	17.5	24	13

B

C

## NOTES & SPECIFICATIONS:

Material, steel



# NITROGEN GAS SPRING BOLT-ON BASE MOUNT

(N12 SERIES)

A

7.5 kN SPRING FORCE

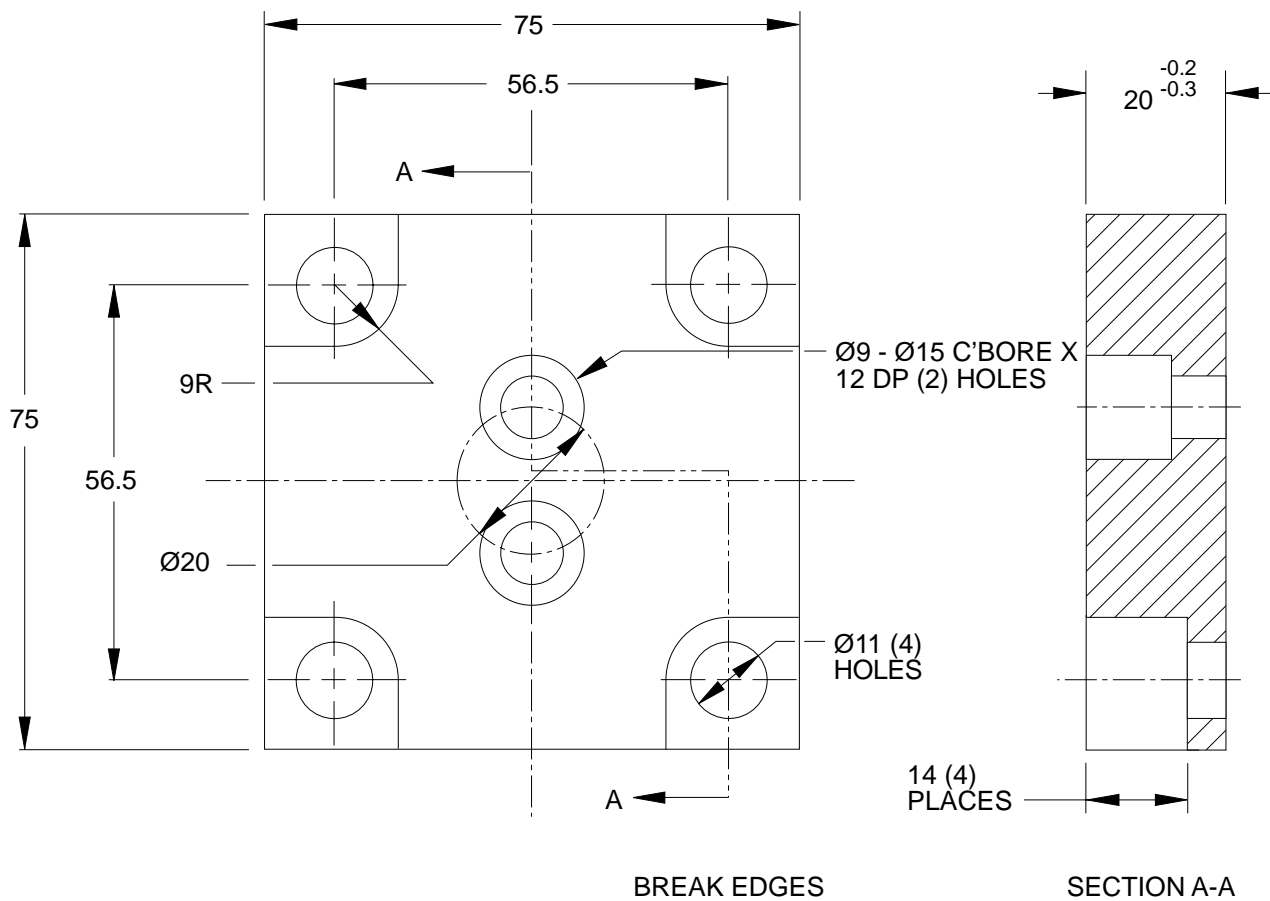

NAAMS CODE	N120700
------------	---------

**NOTES & SPECIFICATIONS:**  
Material, steel

# NITROGEN GAS SPRING BOLT-ON BASE MOUNT

(N12 SERIES)

CONFORMS TO ISO SPECIFICATION 11901-2

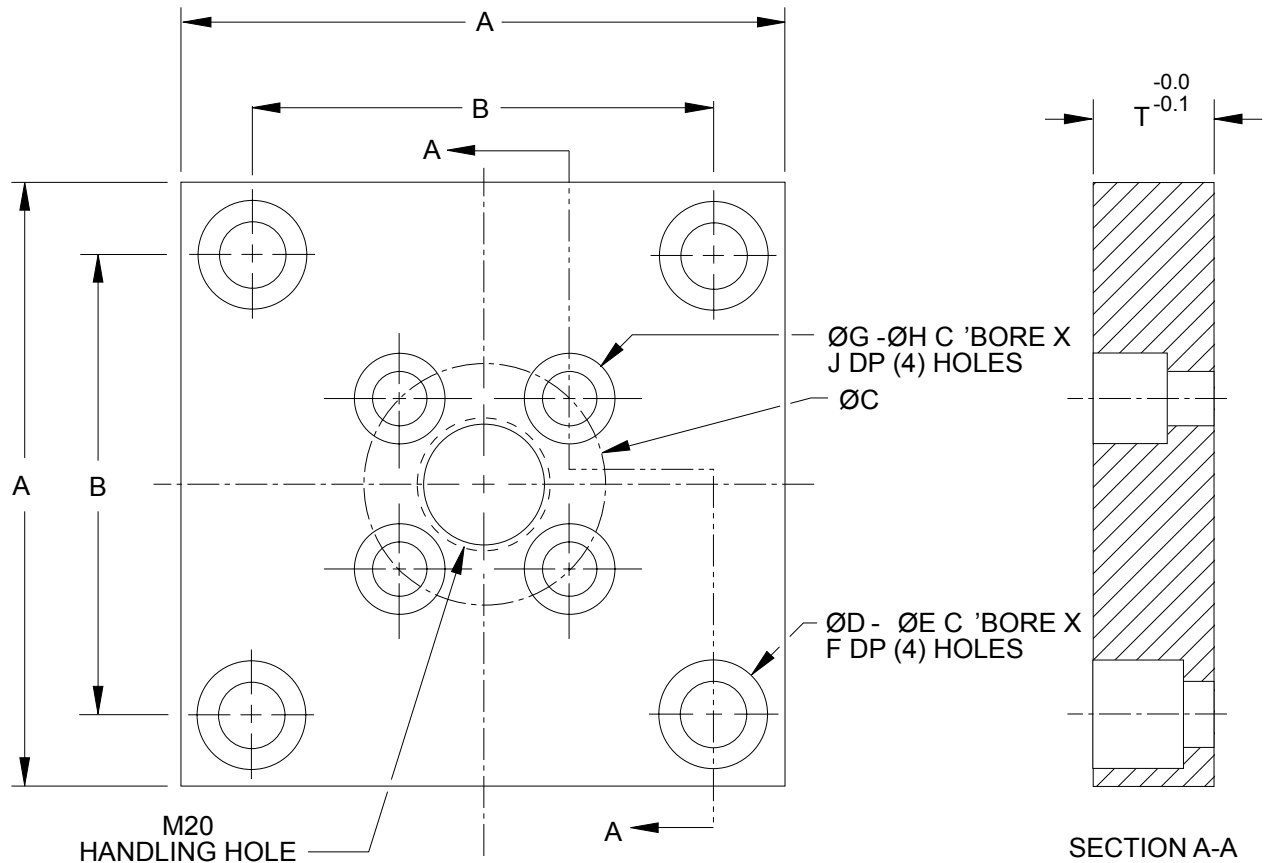

NAAMS CODE	SPRING FORCE (kN)	A	B	ØC	ØD	ØE	F	ØG	ØH	J	T
N121500	15	100	73.5	40	11	18	15	9	15	12	20
N123001	30	120	92	60	13.5	20	13	9	15	12	20
N125001	50	140	109.5	80	13.5	20	13	11	18	15	20
N127501	75	190	138	100	17.5	26	17	11	18	15	25
N129901	100	210	170	120	17.5	26	17	13.5	20	13	25

**NOTES & SPECIFICATIONS:**  
Material, steel

**NITROGEN GAS SPRING  
BOLT-ON BASE MOUNT**

**N127501 MOVED TO PAGE N-10**

# NITROGEN GAS SPRING BOLT-ON BASE MOUNT

(N12 SERIES)

GLOBAL STANDARD COMPONENTS



Stamping

06/27/07

A

CONFORMS TO ISO SPECIFICATION 11901-2

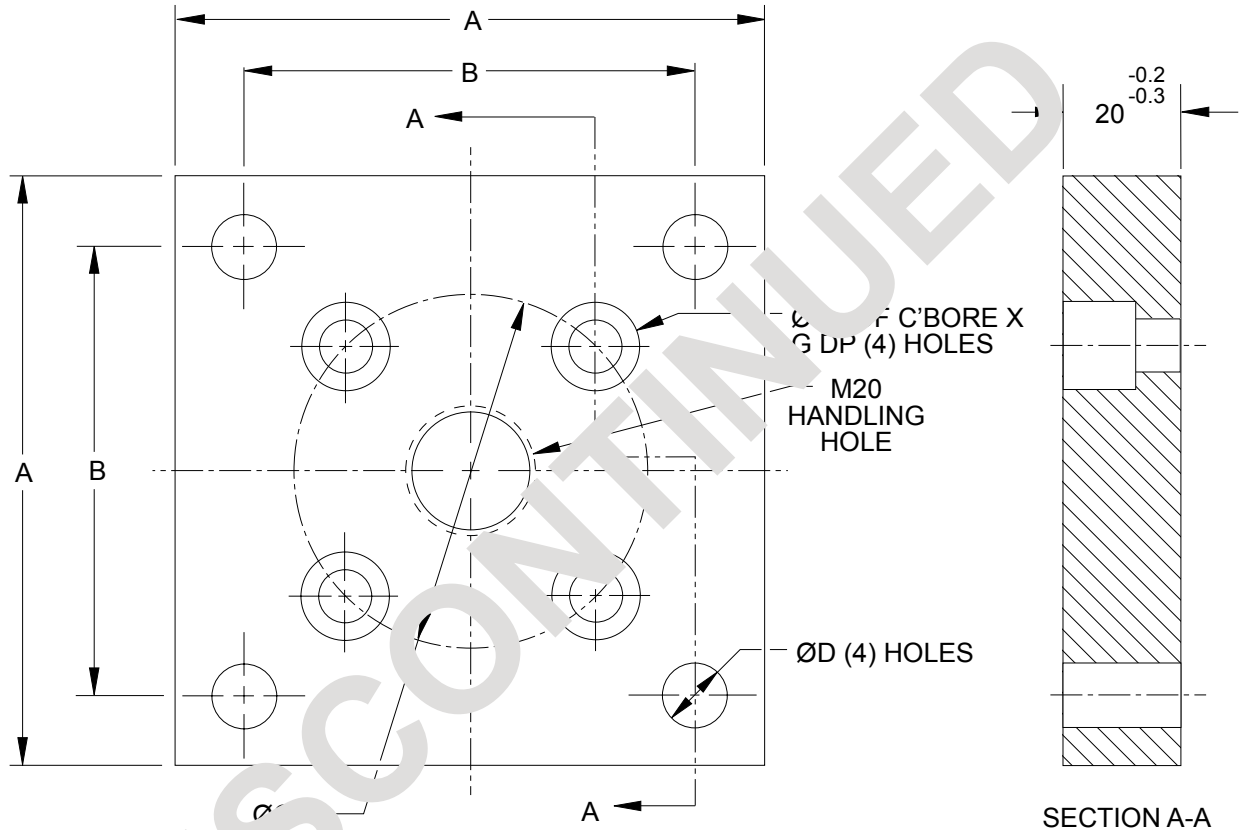

NAAMS CODE	SPRING FORCE (kN)	A	B	ØC	ØD	ØE	ØF	G
N123000	30	120	92.0	60	13.5	9	15	12
N125000	50	140	109.5	80	13.5	11	18	15
N127500	75	190	138.0	100	17.5	11	18	15

**NOTES & SPECIFICATIONS:**  
Material, steel

# NITROGEN GAS SPRING HORIZONTAL FOOT MOUNT - FRONT

(N13 SERIES)

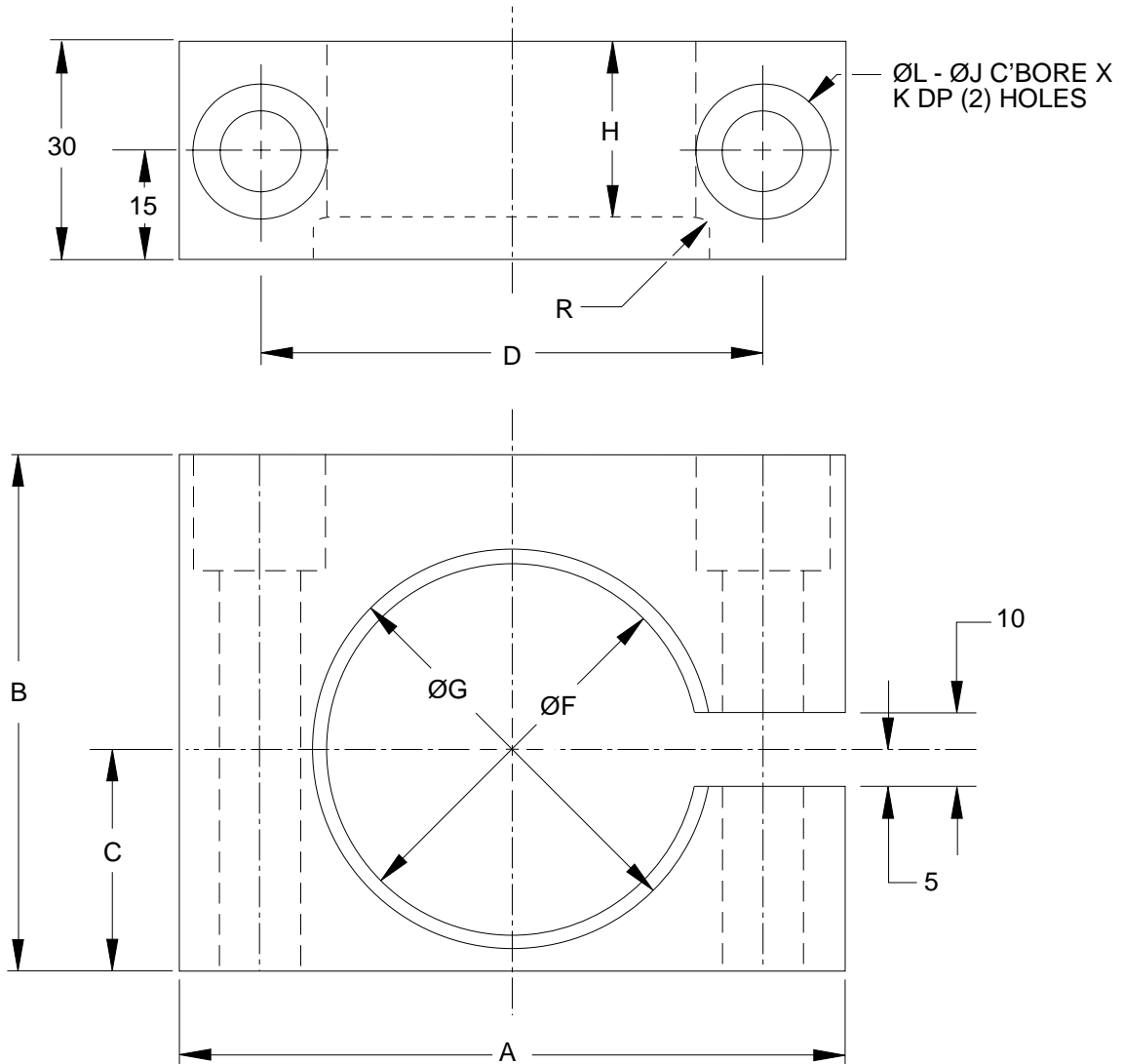

NAAMS CODE	SPRING FORCE (kN)	A	B	C	D	ØF	ØG +0.2 +0.1	H +0.2 +0.1	ØJ +0.1	K	ØL	R
N130700	7.5	90	70	30	68	50.3	54.1	24	18	25	11	2.0
N131500	15	125	94	42	100	75.3	80.0	20.5	20	19	13.5	2.5
N133000	30	140	115	52.5	115	95.3	100.1	20.5	20	40	13.5	2.5

**NOTES & SPECIFICATIONS:**  
Material, steel

# NITROGEN GAS SPRING HORIZONTAL FOOT MOUNT - REAR

(N14 SERIES)

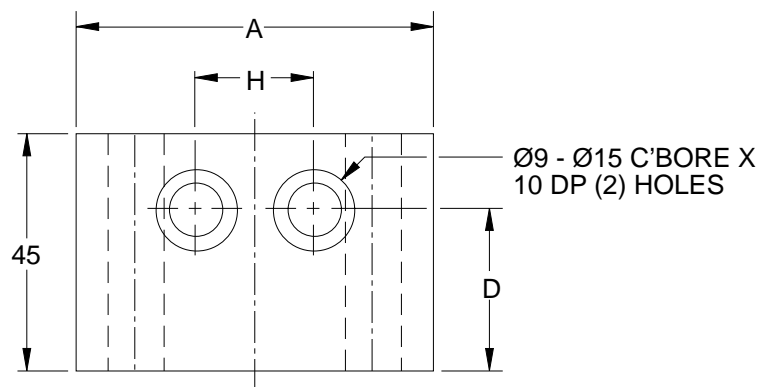
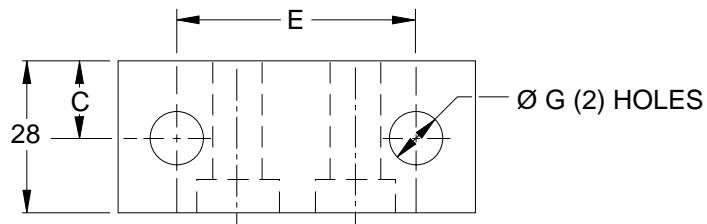

NAAMS CODE	SPRING FORCE (kN)	A	C	D	E	ØG	H	J
N140700	7.5	65	13	30	44	11	20.0	30
N141500	15	80	12	27.8	57	14	28.3	42
N143000	30	95	15	31.2	70	14	42.4	52.2

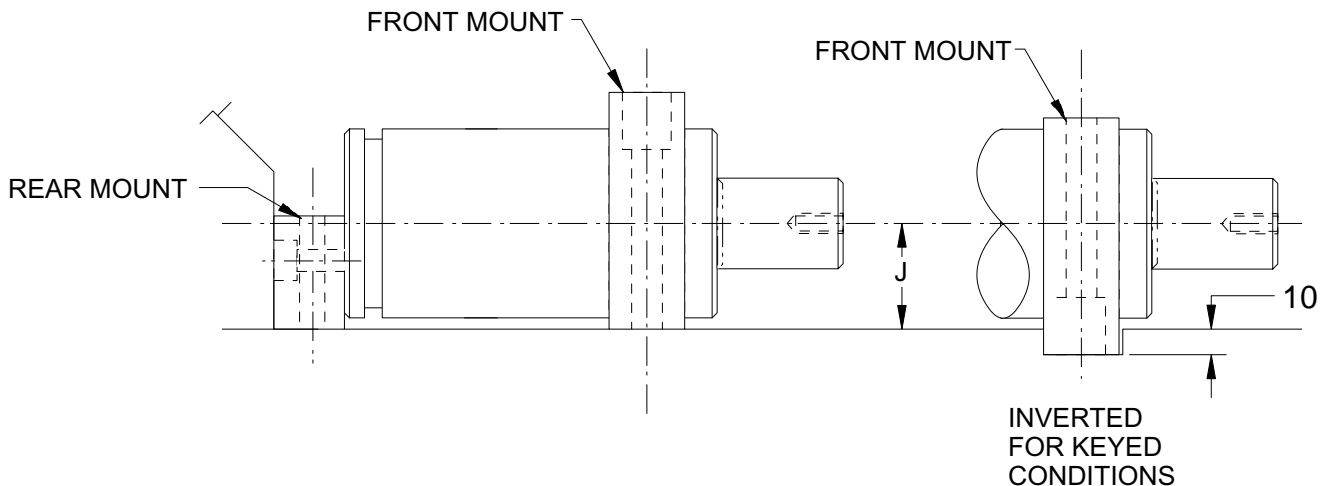

**NOTES & SPECIFICATIONS:**  
Material, steel

**NITROGEN GAS SPRING  
HORIZONTAL FOOT  
MOUNT - REAR (KEYED)**  
(N15 SERIES)

DISCONTINUED

# MISCELLANEOUS STRIPPER - GAS SPRING (N80 & N81 SERIES)

## (N80 SERIES)

SHAPE OF THE ROD  
END IS AT  
MANUFACTURER'S  
DISCRETION

PROVIDE MECHANICAL  
MEANS FOR INSTALLATION  
AND REMOVAL

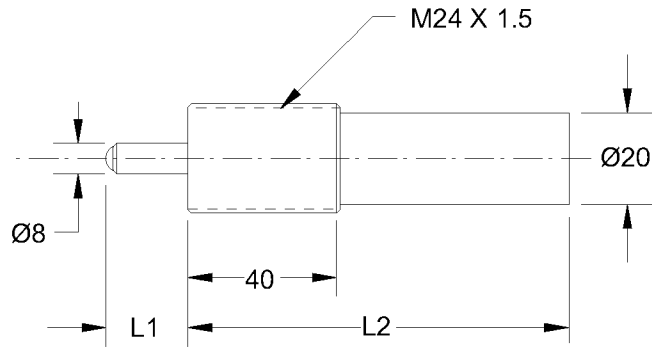

## (N81 SERIES)

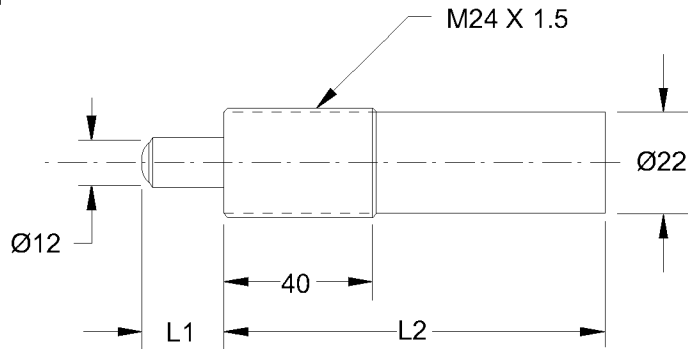

## (N80 SERIES)

Min. Force 100N @ 20 BAR

NAAMS CODE	L1	L2
N802407	07	49
N802415	15	57
N802425	25	67
N802438	38	80
N802450	50	92
N802480	80	125

## (N81 SERIES)

Min. Force 225N @ 20 BAR

NAAMS CODE	L1	L2
N812407	07	47
N812415	15	55
N812425	25	65
N812438	38	78
N812450	50	90
N812480	80	123

A



# MISCELLANEOUS STRIPPER - GAS SPRING

(N82 THRU N88 SERIES)

**(N8X08XX UNITS)**

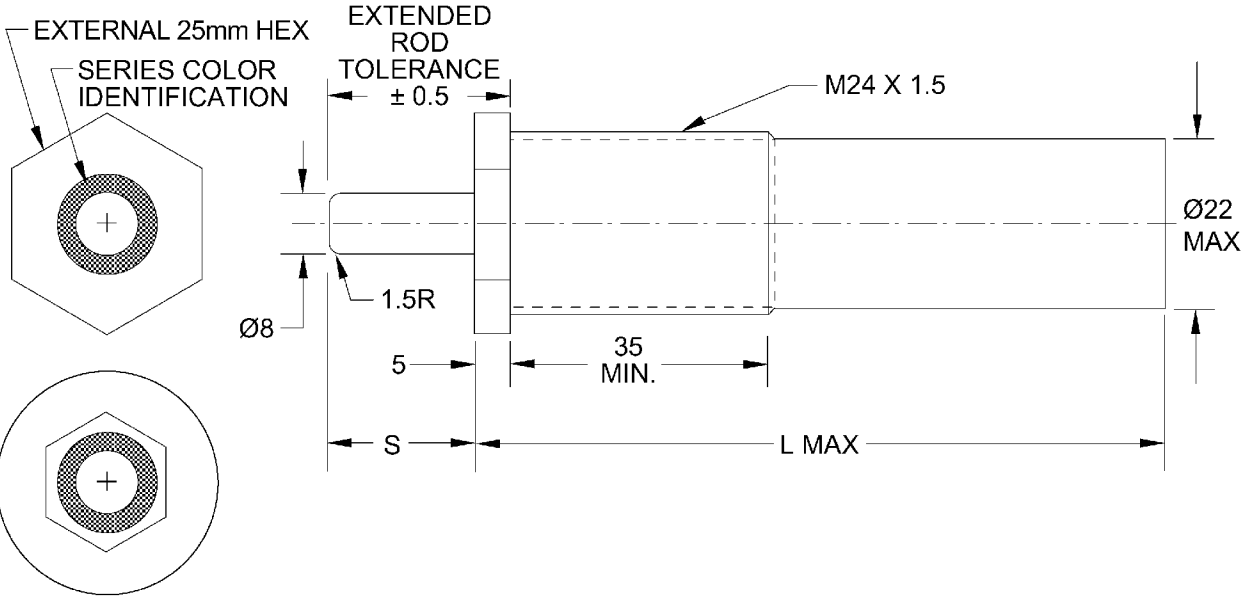

OPTIONAL INTERNAL  
16mm HEX AND  
ROUND COLLAR

SERIES	COLOR	INITIAL FORCE, N	ROD DIA.	NAAMS CODES					
N82	Orange	45-65	8	N820810	N820816	N820825	N820838	N820850	N820880
			12	N821210	N821216	N821225	N821238	N821250	N821280
N83	Purple	90-110	8	N830810	N830816	N830825	N830838	N830850	N830880
			12	N831210	N831216	N831225	N831238	N831250	N831280
N84	Green	225-290	8	N840810	N840816	N840825	N840838	N840850	N840880
			12	N841210	N841216	N841225	N841238	N841250	N841280
N85	Blue	445-510	8	N850810	N850816	N850825	N850838	N850850	N850880
			12	N851210	N851216	N851225	N851238	N851250	N851280
N86	Red	665-735	8	N860810	N860816	N860825	N860838	N860850	N860880
			12	N861210	N861216	N861225	N861238	N861250	N861280
N87	Yellow	890-955	8	N870810	N870816	N870825	N870838	N870850	N870880
			12	N871210	N871216	N871225	N871238	N871250	N871280
N88	Black	Adjustable	8	N880810	N880816	N880825	N880838	N880850	N880880
			12	N881210	N881216	N881225	N881238	N881250	N881280
All	S		10	16	25	38	50	80	
	LMAX		70	76	85	98	110	140	

**A**

**MISCELLANEOUS STRIPPER -  
GAS SPRING**  
(N82 THRU N88 SERIES)

GLOBAL STANDARD COMPONENTS

**NAAMS**



TM

Stamping

09/10/04

*NAAMS CODES MOVED TO PRECEDING PAGE*

# NITROGEN GAS SPRING M50 THREADED BODY AND FLANGE MOUNT

(N90 SERIES)

## 7.5 kN SPRING FORCE

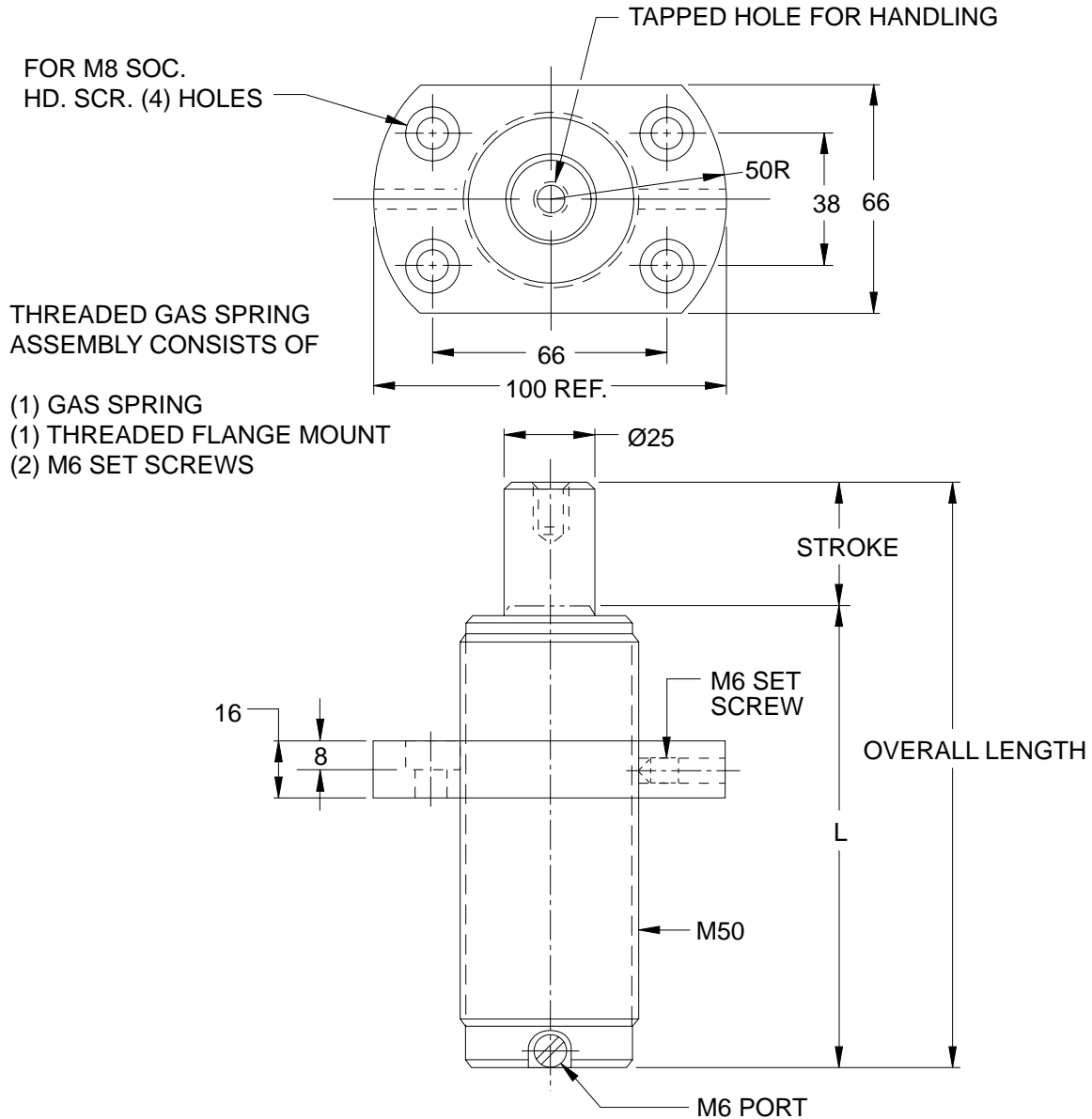

NAAMS CODE	STROKE	L	OVERALL LENGTH
N905002	25	75	100
N905003	38	88	126
N905005	50	100	150
N905006	63	113	176
N905008	80	130	210
N905010	100	100	250
N905012	125	175	300

B

A

# 345 bar NITROGEN CONTROL PANEL

(N76 SERIES)

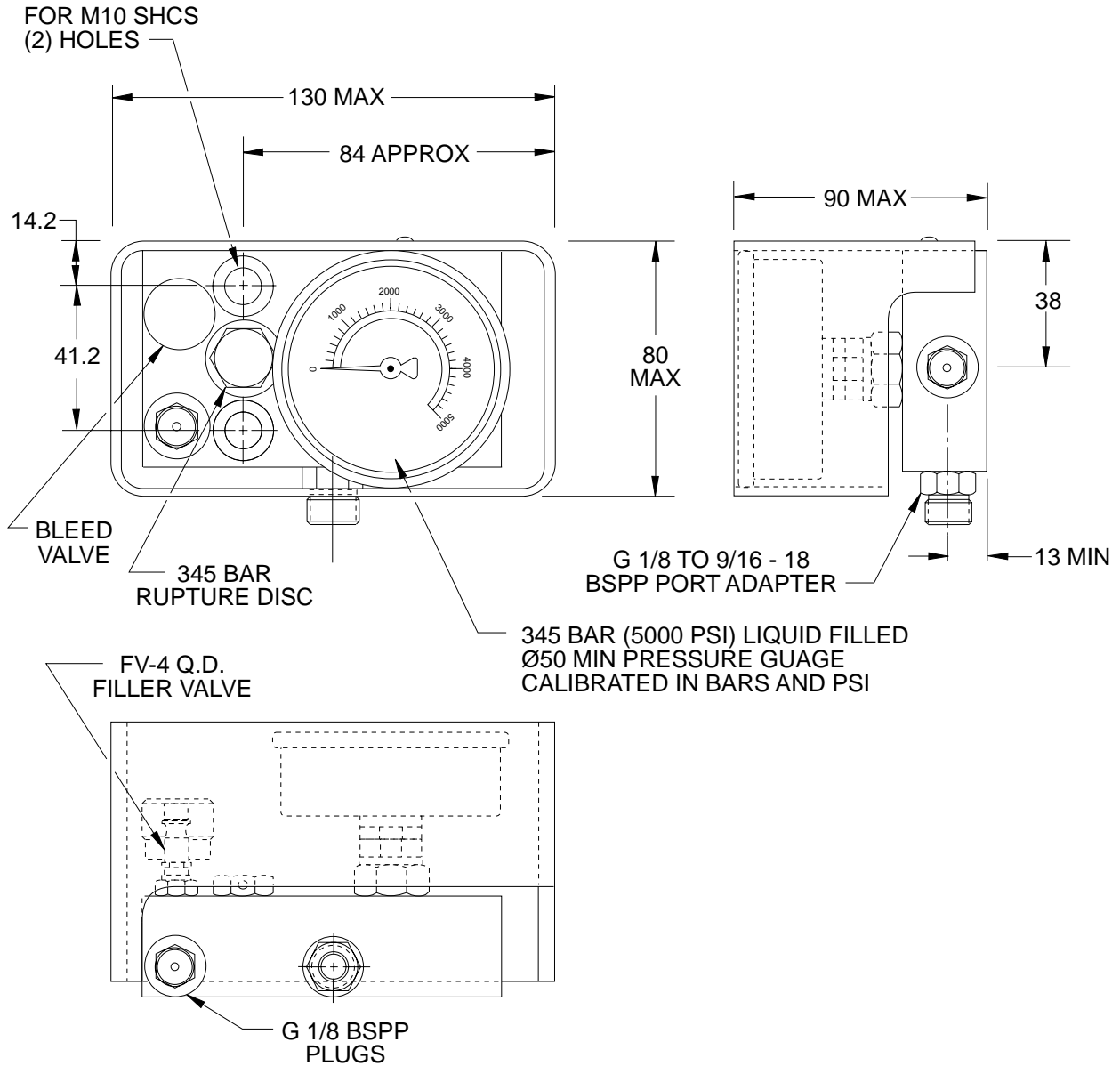

PROTECTIVE HOUSING SHALL BE PAINTED  
 PER US CAR PAINT SPECIFICATIONS.  
 COLOR: MUNSELL NO. 7.5G 4/8 SAFETY GREEN

<b>NAAMS CODE</b>	N761380
-------------------	---------

**A**

# O-RING FACE STYLE CLAMP HOSE FITTINGS

(N51 SERIES)

GLOBAL STANDARD COMPONENTS



Stamping

12/15/00

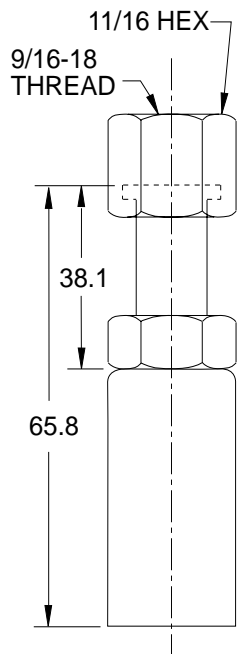

**STRAIGHT  
FOR 1/4" HOSE**

**NAAMS CODE** N514400

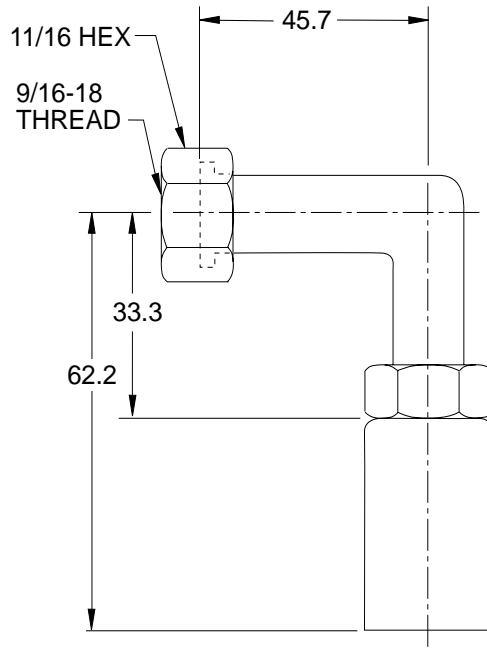

**90° LONG ELBOW  
FOR 1/4" HOSE**

**NAAMS CODE** N514490

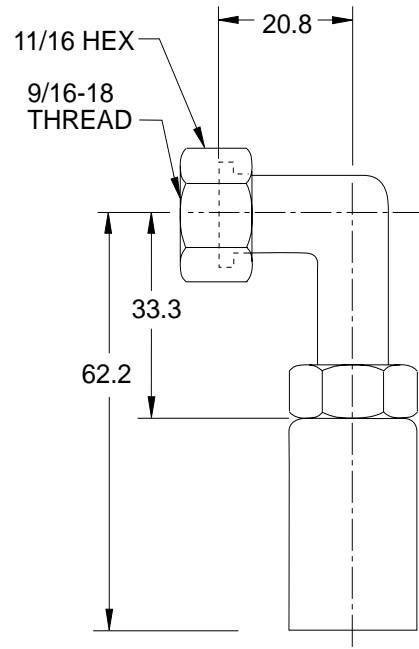

**90° SHORT ELBOW  
FOR 1/4" HOSE**

**NAAMS CODE** N514491

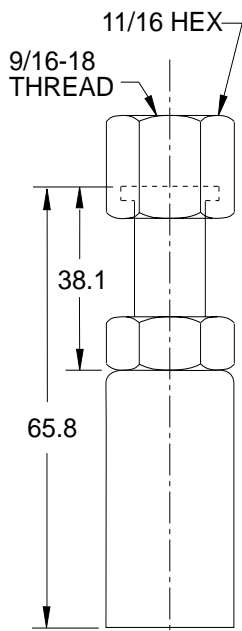

**STRAIGHT  
FOR 3/16" HOSE**

**NAAMS CODE** N514300

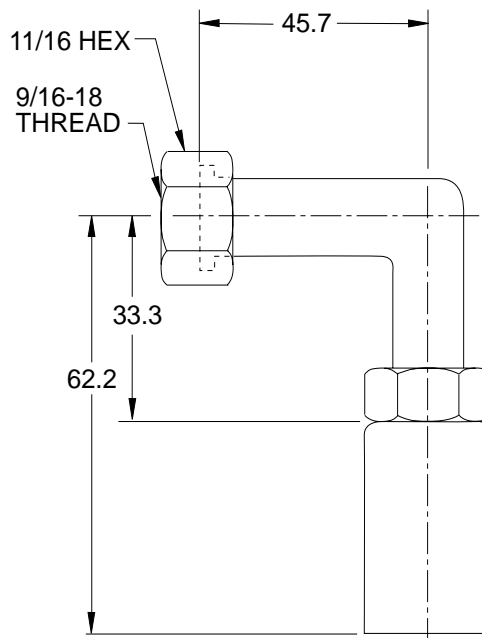

**90° ELBOW  
FOR 3/16" HOSE**

**NAAMS CODE** N514390

**B**

**A**

# O-RING FACE FITTINGS

(N52 SERIES)

Stamping

12/15/00

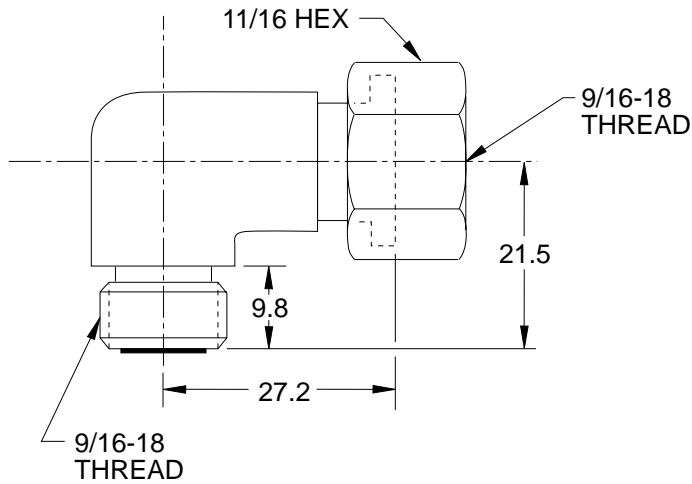

**SWIVEL NUT ELBOW**  
**SAE NO. 4-4 520221-S**

<b>NAAMS CODE</b>	N520221
-------------------	---------

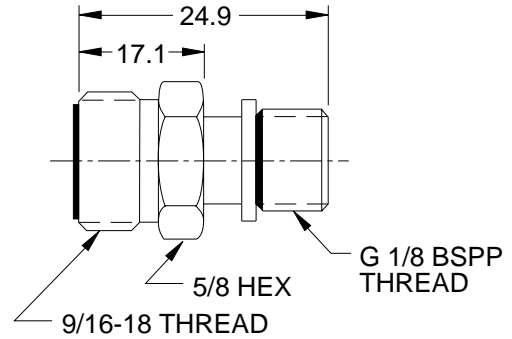

**STRAIGHT THREAD CONNECTOR**

<b>NAAMS CODE</b>	N520121
-------------------	---------

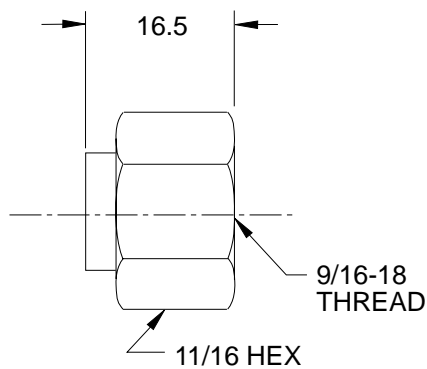

**END CAP**  
**SAE NO. 4-520112-S**

<b>NAAMS CODE</b>	N520112
-------------------	---------

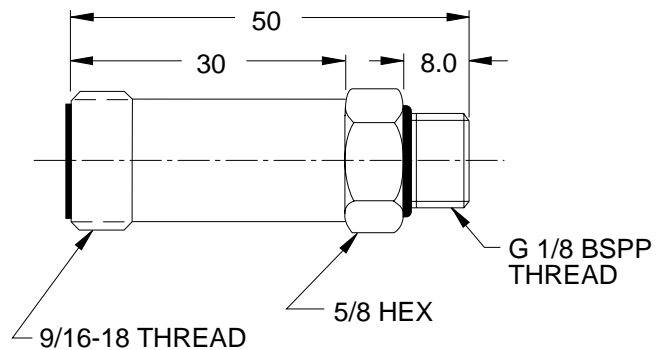

**LONG STRAIGHT THREAD CONNECTOR**

<b>NAAMS CODE</b>	N520122
-------------------	---------

**B**

**A**

# O-RING FACE FITTINGS

(N52 SERIES)

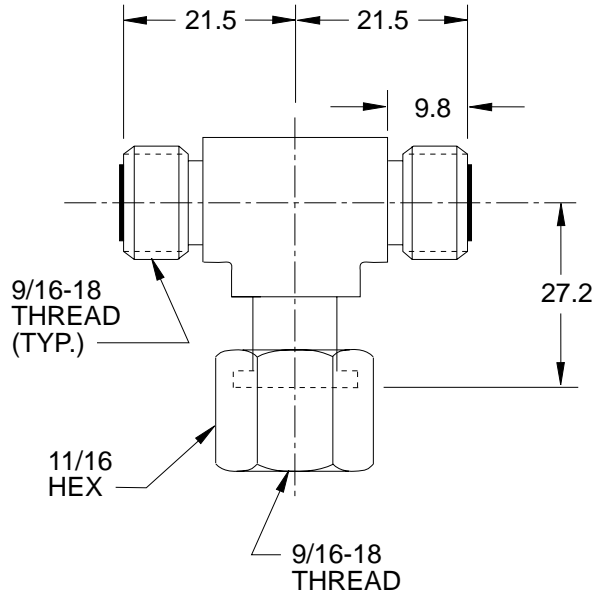

**SWIVEL NUT BRANCH TEE**  
**SAE. NO. 4-4 520433-S**

<b>NAAMS CODE</b>	N520433
-------------------	---------

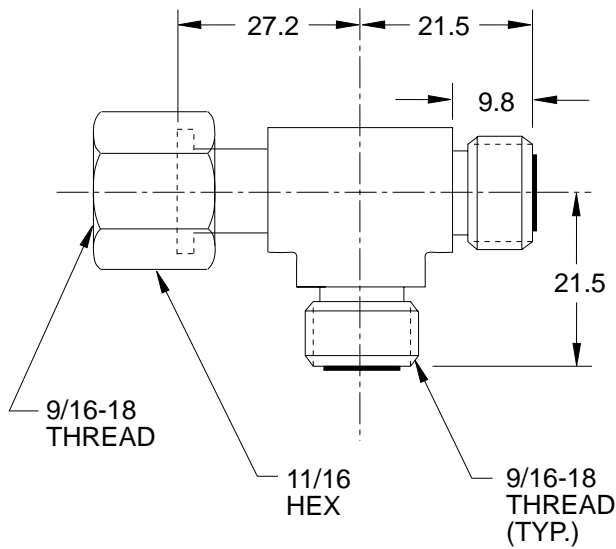

**SWIVEL NUT RUN TEE**  
**SAE. NO. 4-4 520432-S**

<b>NAAMS CODE</b>	N520432
-------------------	---------

# O-RING FACE FITTINGS

(N52 SERIES)

Stamping

12/15/00

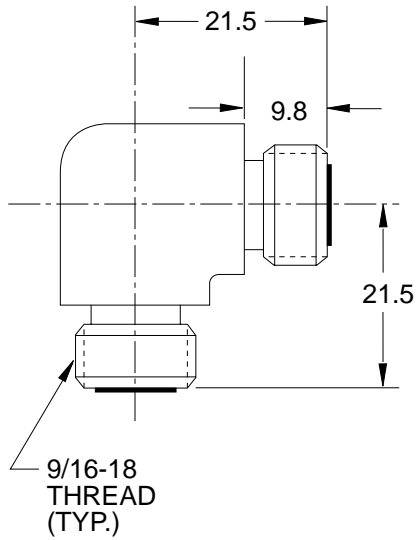

**90° UNION ELBOW**  
**SAE NO. 4-520201-S**

<b>NAAMS CODE</b>	N520201
-------------------	---------

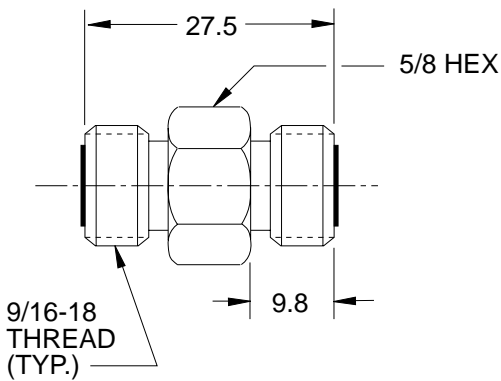

**UNION**  
**SAE NO. 4-520101-S**

<b>NAAMS CODE</b>	N520101
-------------------	---------

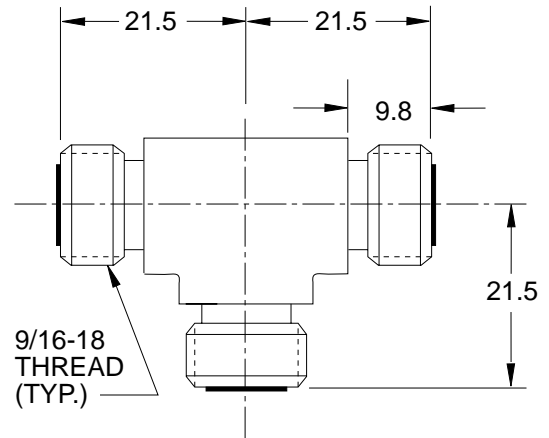

**UNION TEE**  
**SAE NO. 4-520401-S**

<b>NAAMS CODE</b>	N520401
-------------------	---------

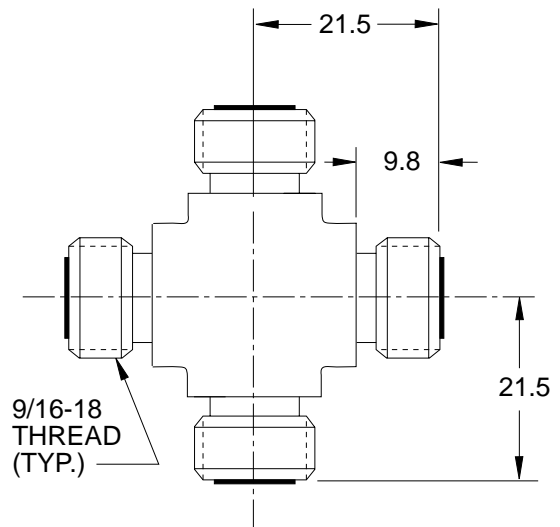

**UNION CROSS**  
**SAE NO. 4-520501-S**

<b>NAAMS CODE</b>	N520501
-------------------	---------



# NITROGEN GAS SYSTEM

HOSE AND CLAMPS

(N91 SERIES)

GLOBAL STANDARD COMPONENTS



Stamping

12/15/00

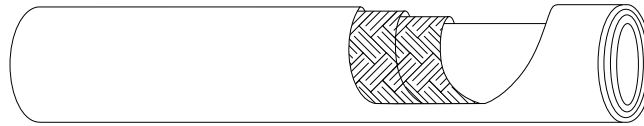

## HIGH PRESSURE HOSE - ARAMID FIBER BRAIDED

MEETS OR EXCEEDS SAE 100R8 SPECIFICATIONS

SAE 100R8 3/16 W.P. 5000 PSI

SAE 100R8 1/4 W.P. 5000 PSI

	3/16	1/4
HOSE I.D. mm (in)	4.8(0.19)	6.35(0.25)
HOSE O.D. mm (in)	10.9(0.43)	12.95(0.51)
MAXIMUM WORKING PRESSURE BAR (PSI)	345(5000)	345(5000)
MINIMUM BURST PRESSURE BAR (PSI)	1380(20,000)	1380(20,000)
MINIMUM BEND RADIUS mm	38	50
TEMPERATURE RANGE C (F)	-40(-40) TO 93(200)	-40(-40) TO 93(200)

- NOTE:
- WHEN ORDERING HOSING, ORDER EXTRA 15 mm TO ALLOW FOR HOSE MOVEMENT DURING PRESSURE CYCLING.
  - MINIMUM HOSE LENGTH BETWEEN CRIMPED FITTINGS SHOULD BE 20 mm MINIMUM

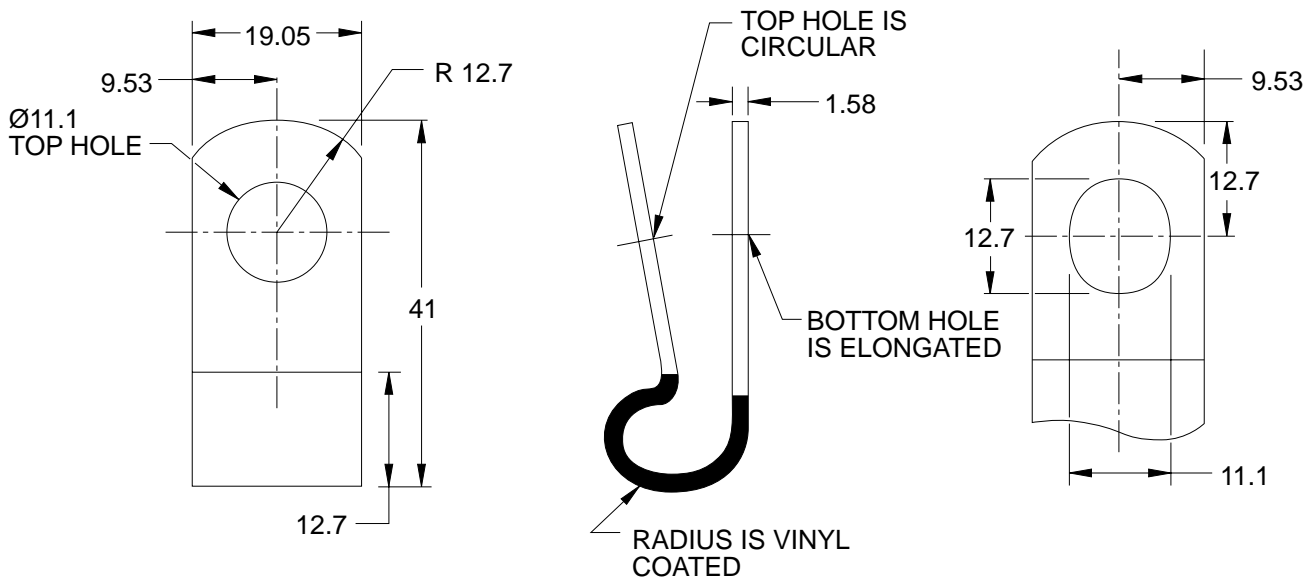

### HOSE CLAMP

NAAMS CODE	N910000
------------	---------

A