

# POWER CLAMP INDEX

<b>PAGE</b>	<b>DATE</b>	<b>NAAMS CODE</b>	<b>OFFSET</b>	<b>DESCRIPTION</b>	<b>DISCONTINUED</b>
<a href="#">G-1</a>	09/05/12			Power Clamp Index	
<a href="#">G-1.1</a>	11/10/10			Power Clamp Index	
<a href="#">G-1.2</a>	09/05/12			Power Clamp Index	
<a href="#">G-1.3</a>	09/05/12			Power Clamp Index	
<a href="#">G-1.4</a>	06/04/07			Power Clamp Arms Specifications	
<a href="#">G-2</a>	11/10/10	ACA001M–ACA006M	Straight	Power Clamp Arms Blanks 60 Series (Full Metric)	
<a href="#">G-3</a>	11/10/10	ACA013M–ACA018M	20 mm	Power Clamp Arms Blanks 60 Series (Full Metric)	
<a href="#">G-4</a>	11/10/10	ACA025M–ACA030M	65 mm	Power Clamp Arms Blanks 60 Series (Full Metric)	
<a href="#">G-5</a>	11/10/10	ACA037M–ACA042M	115 mm	Power Clamp Arms Blanks 60 Series (Full Metric)	
<a href="#">G-6</a>	11/10/10	ACA007M–ACA012M	Straight	Power Clamp Arms 60 Series (Machined) (Full Metric)	
<a href="#">G-7</a>	11/10/10	ACA007M–ACA012M	Straight	Power Clamp Arms 60 Series (Machined) (Full Metric)	
<a href="#">G-8</a>	11/10/10	ACA019M–ACA024M	25 mm	Power Clamp Arms 60 Series (Machined) (Full Metric)	
<a href="#">G-9</a>	11/10/10	ACA019M–ACA024M	25 mm	Power Clamp Arms 60 Series (Machined) (Full Metric)	
<a href="#">G-10</a>	11/10/10	ACA031M–ACA036M	70 mm	Power Clamp Arms 60 Series (Machined) (Full Metric)	
<a href="#">G-11</a>	11/10/10	ACA031M–ACA036M	70 mm	Power Clamp Arms 60 Series (Machined) (Full Metric)	
<a href="#">G-12</a>	11/10/10	ACA043M–ACA048M	120 mm	Power Clamp Arms 60 Series (Machined) (Full Metric)	
<a href="#">G-13</a>	11/10/10	ACA043M–ACA048M	120 mm	Power Clamp Arms 60 Series (Machined) (Full Metric)	
<a href="#">G-14</a>	11/10/10	ACA100M–ACA108M	Straight	Power Clamp Arms Blanks 80/90 Series (Inch and Metric Designs)	
<a href="#">G-15</a>	11/10/10	ACA120M–ACA128M	20 mm	Power Clamp Arms Blanks 80/90 Series (Inch and Metric Designs)	
<a href="#">G-16</a>	11/10/10	ACA140M–ACA148M	65mm	Power Clamp Arms Blanks 80/90 Series (Inch and Metric Designs)	
<a href="#">G-17</a>	11/10/10	ACA160M–ACA168M	115 mm	Power Clamp Arms Blanks 80/90 Series (Inch and Metric Designs)	
<a href="#">G-18</a>	11/10/10	ACA110M–ACA118M	Straight	Power Clamp Arm 80/90 Series (Machined) (Full Metric)	
<a href="#">G-19</a>	11/10/10	ACA110M–ACA118M	Straight	Power Clamp Arms 80/90 Series (Machined) (Full Metric)	
<a href="#">G-20</a>	11/10/10	ACA130M–ACA138M	25 mm	Power Clamp Arms 80/90 Series (Machined) (Full Metric)	
<a href="#">G-21</a>	11/10/10	ACA130M–ACA138M	25 mm	Power Clamp Arms 80/90 Series (Machined) (Full Metric)	
<a href="#">G-22</a>	11/10/10	ACA150M–ACA158M	70 mm	Power Clamp Arms 80/90 Series (Machined) (Full Metric)	
<a href="#">G-23</a>	11/10/10	ACA150M–ACA158M	70 mm	Power Clamp Arms 80/90 Series (Machined) (Full Metric)	
<a href="#">G-24</a>	11/10/10	ACA170M–ACA178M	120 mm	Power Clamp Arms 80/90 Series (Machined) (Full Metric)	
<a href="#">G-25</a>	11/10/10	ACA170M–ACA178M	120 mm	Power Clamp Arms 80/90 Series (Machined) (Full Metric)	

# POWER CLAMP INDEX

PAGE	DATE	NAAMS CODE	OFFSET	DESCRIPTION	DISCONTINUED
<a href="#">G-26</a>	11/10/10	ACA001-ACA006	Straight	Power Clamp Arms Blanks 60 Series (Inch and Metric Designs)	X
<a href="#">G-27</a>	11/10/10	ACA013-ACA018	20 mm	Power Clamp Arms Blanks 60 Series (Inch and Metric Designs)	X
<a href="#">G-28</a>	11/10/10	ACA025-ACA030	60 mm	Power Clamp Arms Blanks 60 Series (Inch and Metric Designs)	X
<a href="#">G-29</a>	11/10/10	ACA037-ACA042	115 mm	Power Clamp Arms Blanks 60 Series (Inch and Metric Designs)	X
<a href="#">G-30</a>	11/10/10	ACA007-ACA012	Straight	Power Clamp Arms 60 Series (Machined)	X
<a href="#">G-31</a>	11/10/10	ACA007-ACA012	Straight	Power Clamp Arms 60 Series (Machined)	X
<a href="#">G-32</a>	11/10/10	ACA019-ACA024	25 mm	Power Clamp Arms 60 Series (Machined)	X
<a href="#">G-33</a>	11/10/10	ACA019-ACA024	25 mm	Power Clamp Arms 60 Series (Machined)	X
<a href="#">G-34</a>	11/10/10	ACA031-ACA036	70 mm	Power Clamp Arms 60 Series (Machined)	X
<a href="#">G-35</a>	11/10/10	ACA031-ACA036	70 mm	Power Clamp Arms 60 Series (Machined)	X
<a href="#">G-36</a>	11/10/10	ACA043-ACA048	120 mm	Power Clamp Arms 60 Series (Machined)	X
<a href="#">G-37</a>	11/10/10	ACA043-ACA048	120 mm	Power Clamp Arms 60 Series (Machined)	X
<a href="#">G-38</a>	11/10/10	ACA110-ACA118	Straight	Power Clamp Arms 80/90 Series (Machined)	X
<a href="#">G-39</a>	11/10/10	ACA110-ACA118	Straight	Power Clamp Arms 80/90 Series (Machined)	X
<a href="#">G-40</a>	11/10/10	ACA130-ACA138	25 mm	Power Clamp Arms 80/90 Series (Machined)	X
<a href="#">G-41</a>	11/10/10	ACA130-ACA138	25 mm	Power Clamp Arms 80/90 Series (Machined)	X
<a href="#">G-42</a>	11/10/10	ACA150-ACA158	70 mm	Power Clamp Arms 80/90 Series (Machined)	X
<a href="#">G-43</a>	11/10/10	ACA150-ACA158	70 mm	Power Clamp Arms 80/90 Series (Machined)	X
<a href="#">G-44</a>	11/10/10	ACA170-ACA178	120 mm	Power Clamp Arms 80/90 Series (Machined)	X
<a href="#">G-45</a>	11/10/10	ACA170-ACA178	120 mm	Power Clamp Arms 80/90 Series (Machined)	X
<a href="#">G-46</a>	11/10/10			Enclosed Clamp Hole 50 Series Pattern #1	
<a href="#">G-47</a>	11/10/10			Enclosed Clamp Hole 60 Series Pattern #2	
<a href="#">G-48</a>	11/10/10			Enclosed Clamp Hole 80/90 Series Pattern #3	
<a href="#">G-49</a>	11/10/10	ACA201M-ACA203M	Straight	Power Clamp Arms Blanks 50 Series (Full Metric)	
<a href="#">G-50</a>	11/10/10	ACA211M-ACA213M	20 mm	Power Clamp Arms Blanks 50 Series (Full Metric)	
<a href="#">G-51</a>	11/10/10	ACA221M-ACA223M	45 mm	Power Clamp Arms Blanks 50 Series (Full Metric)	

# POWER CLAMP INDEX

PAGE	DATE	NAAMS CODE	OFFSET	DESCRIPTION	DISCONTINUED
<a href="#">G-52</a>	11/10/10	ACA206M-ACA208M	Straight	Power Clamp Arms 50 Series (Machined) (Full Metric)	X
<a href="#">G-53</a>	04/30/15	ACA216M-ACA218M	25 mm	Power Clamp Arms 50 Series (Machined) (Full Metric)	X
<a href="#">G-54</a>	11/10/10	ACA226M-ACA228M	50 mm	Power Clamp Arms 50 Series (Machined) (Full Metric)	X
<a href="#">G-55</a>	11/10/10	ACA226M-ACA228M	50 mm	Power Clamp Arms 50 Series (Machined) (Full Metric)	X
<a href="#">G-56</a>	09/05/12	ACA236M-ACA238M	Straight	Power Clamp Arms 50 Series (Machined) (Full Metric)	
<a href="#">G-57</a>	09/05/12	ACA246M-ACA248M	25 mm	Power Clamp Arms 50 Series (Machined) (Full Metric)	
<a href="#">G-58</a>	09/05/12	ACA256M-ACA258M	50 mm	Power Clamp Arms 50 Series (Machined) (Full Metric)	
<a href="#">G-59</a>	11/10/10	ACA256M-ACA258M	50 mm	Power Clamp Arms 50 Series (Machined) (Full Metric)	
<a href="#">G-60</a>	11/10/10			60 Series Power Clamp Envelope	
<a href="#">G-61</a>	11/10/10			60 Series Power Clamp Optional Mounting	
<a href="#">G-62</a>	11/10/10			50 Series Power Clamp Envelope	
<a href="#">G-63</a>	11/10/10			50 Series Power Clamp Optional Mounting	
<a href="#">G-64</a>	11/10/10			80/90 Series Power Clamp Envelope	
<a href="#">G-65</a>	11/10/10			80/90 Series Power Clamp Optional Mounting	
<a href="#">G-66</a>	09/05/12	ACA301M-ACA303M	25mm	Wishbone Clamp Arms 50 Series	X
<a href="#">G-67</a>	11/10/10	ACA301M-ACA303M	25mm	Wishbone Clamp Arms 50 Series	X
<a href="#">G-68</a>	09/05/12	ACA311M-ACA313M	50mm	Wishbone Clamp Arms 50 Series	X
<a href="#">G-69</a>	11/10/10	ACA311M-ACA313M	50mm	Wishbone Clamp Arms 50 Series	X
<a href="#">G-70</a>	09/05/12	ACA320M-ACA325M	25mm	Wishbone Clamp Arms 60 Series	X
<a href="#">G-71</a>	11/10/10	ACA320M-ACA325M	25mm	Wishbone Clamp Arms 60 Series	X
<a href="#">G-72</a>	09/05/12	ACA330M-ACA335M	70mm	Wishbone Clamp Arms 60 Series	X
<a href="#">G-73</a>	11/10/10	ACA330M-ACA335M	70mm	Wishbone Clamp Arms 60 Series	X
<a href="#">G-74</a>	09/05/12	ACA401M-ACA403M	Straight	Power Clamp Arms 50 Series (Machined) (Full Metric)	
<a href="#">G-75</a>	09/05/12	ACA411M-ACA413M	25mm	Power Clamp Arms 50 Series (Machined) (Full Metric)	
<a href="#">G-76</a>	09/05/12	ACA421M-ACA423M	50mm	Power Clamp Arms 50 Series (Machined) (Full Metric)	
<a href="#">G-77</a>	11/10/10	ACA421M-ACA423M	50mm	Power Clamp Arms 50 Series (Machined) (Full Metric)	
<a href="#">G-78</a>	09/05/12	ACA431M-ACA433M	25mm	Wishbone Clamp Arms 50 Series	X
<a href="#">G-79</a>	11/10/10	ACA431M-ACA433M	25mm	Wishbone Clamp Arms 50 Series	X
<a href="#">G-80</a>	09/05/12	ACA441M-ACA443M	50mm	Wishbone Clamp Arms 50 Series	X

# POWER CLAMP INDEX

PAGE	DATE	NAAMS CODE	OFFSET	DESCRIPTION	DISCONTINUED
<a href="#">G-81</a>	11/10/10	ACA441M-ACA443M	50mm	Wishbone Clamp Arms 50 Series	X
<a href="#">G-82</a>	09/05/12	ACA451M-ACA456M	25mm	Wishbone Clamp Arms 60 Series	X
<a href="#">G-83</a>	11/10/10	ACA451M-ACA456M	25mm	Wishbone Clamp Arms 60 Series	X
<a href="#">G-84</a>	09/05/12	ACA461M-ACA466M	70mm	Wishbone Clamp Arms 60 Series	X
<a href="#">G-85</a>	11/10/10	ACA461M-ACA466M	70mm	Wishbone Clamp Arms 60 Series	X
<a href="#">G-86</a>	09/05/12	ACA507M-ACA512M	Straight	Power Clamp Arms 60 Series (Machined - 20 mm Wide)	
<a href="#">G-87</a>	11/10/10	ACA507M-ACA512M	Straight	Power Clamp Arms 60 Series (Machined - 20 mm Wide)	
<a href="#">G-88</a>	09/05/12	ACA519M-ACA524M	25mm	Power Clamp Arms 60 Series (Machined - 20 mm Wide)	
<a href="#">G-89</a>	11/10/10	ACA519M-ACA524M	25mm	Power Clamp Arms 60 Series (Machined - 20 mm Wide)	
<a href="#">G-90</a>	09/05/12	ACA531M-ACA536M	70mm	Power Clamp Arms 60 Series (Machined - 20 mm Wide)	
<a href="#">G-91</a>	11/10/10	ACA531M-ACA536M	70mm	Power Clamp Arms 60 Series (Machined - 20 mm Wide)	
<a href="#">G-92</a>	09/05/12	ACA543M-ACA548M	120mm	Power Clamp Arms 60 Series (Machined - 20 mm Wide)	
<a href="#">G-93</a>	11/10/10	ACA543M-ACA548M	120mm	Power Clamp Arms 60 Series (Machined - 20 mm Wide)	
<a href="#">G-94</a>	09/05/12	ACA513M-ACA518M	Straight	Power Clamp Arms 60 Series (Machined - 20 mm Wide)	
<a href="#">G-95</a>	11/10/10	ACA513M-ACA518M	Straight	Power Clamp Arms 60 Series (Machined - 20 mm Wide)	
<a href="#">G-96</a>	09/05/12	ACA525M-ACA530M	25mm	Power Clamp Arms 60 Series (Machined - 20 mm Wide)	
<a href="#">G-97</a>	11/10/10	ACA525M-ACA530M	25mm	Power Clamp Arms 60 Series (Machined - 20 mm Wide)	
<a href="#">G-98</a>	09/05/12	ACA537M-ACA542M	70mm	Power Clamp Arms 60 Series (Machined - 20 mm Wide)	
<a href="#">G-99</a>	11/10/10	ACA537M-ACA542M	70mm	Power Clamp Arms 60 Series (Machined - 20 mm Wide)	
<a href="#">G-100</a>	09/05/12	ACA549M-ACA554M	120mm	Power Clamp Arms 60 Series (Machined - 20 mm Wide)	
<a href="#">G-101</a>	11/10/10	ACA549M-ACA554M	120mm	Power Clamp Arms 60 Series (Machined - 20 mm Wide)	
<a href="#">G-102</a>	04/30/15	ACA201G-ACA203G	Straight	Power Clamp Arms 50 Series Gripper Clamping Components (Machined - 20 mm Wide)	
<a href="#">G-103</a>	04/30/15	ACA211G-ACA213G	25mm	Power Clamp Arms 50 Series Gripper Clamping Components (Machined - 20 mm Wide)	
<a href="#">G-104</a>	04/30/15	ACA221G-ACA223G	50mm	Power Clamp Arms 50 Series Gripper Clamping Components (Machined - 20 mm Wide)	

# POWER CLAMP ARMS SPECIFICATIONS

PAINT DESIGNATED SURFACES MINIMUM PER US CAR PAINT SPECIFICATIONS.  
COLOR: MUNSELL NO. 3.75YR6/14 SAFETY ORANGE

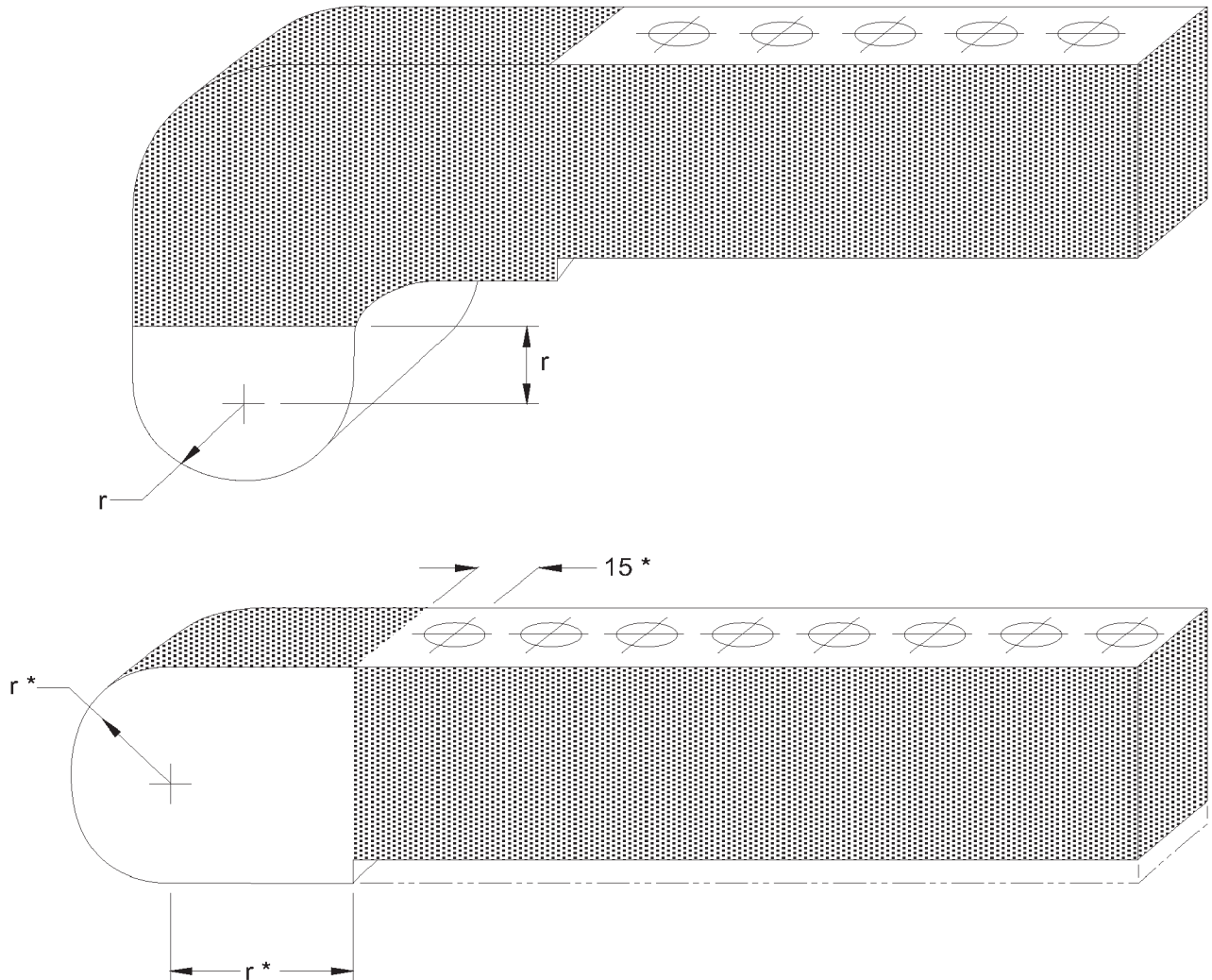

\* These dimensions apply only to ACA206M, ACA207M and ACA208M arms, which are not notched



Indicates designated surfaces to be painted.

MATERIAL SPEC: 1045 STEEL IS AN ACCEPTABLE ALTERNATIVE TO 4140 FOR CLAMP ARMS.

D

C

A

B

# POWER CLAMP ARMS BLANKS

## 60 SERIES

(STRAIGHT) (FULL METRIC)

E

A

B

D

C

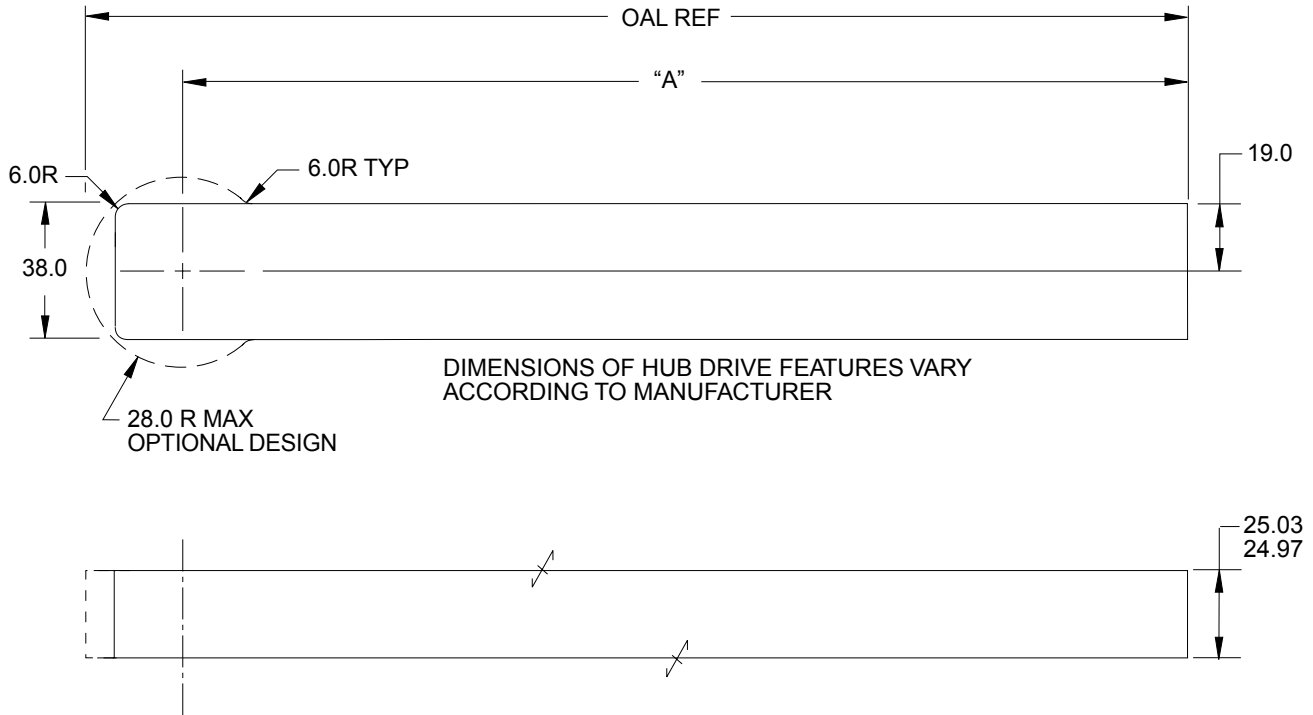

STAMP OR ETCH THE NAAMS CODE NUMBER AND THE CLAMP ARM MANUFACTURER'S NUMBER, IF DIFFERENT, ON THE SIDE OF THE ARM.

EXCEPT AS NOTED TOLERANCES SHALL BE:

- 1 PLACE MACHINING  $\pm 0.3$
- 1 PLACE FABRICATION  $\pm 1.5$

MATERIAL: SAE 4140 or SAE 1045

NOTES: ALL DIMENSIONS METRIC UNLESS OTHERWISE NOTED.

NAAMS CODE	DIM. "A"	MAX OAL (REF)	WEIGHT kg
ACA001M	135.0	163.0	1.2
ACA002M	165.0	193.0	1.4
ACA003M	195.0	223.0	1.6
ACA004M	225.0	253.0	1.9
ACA005M	255.0	283.0	2.1
ACA006M	285.0	313.0	2.3

# POWER CLAMP ARMS BLANKS 60 SERIES

(20mm OFFSET) (FULL METRIC)

GLOBAL STANDARD COMPONENTS



Assembly

11/10/10

D

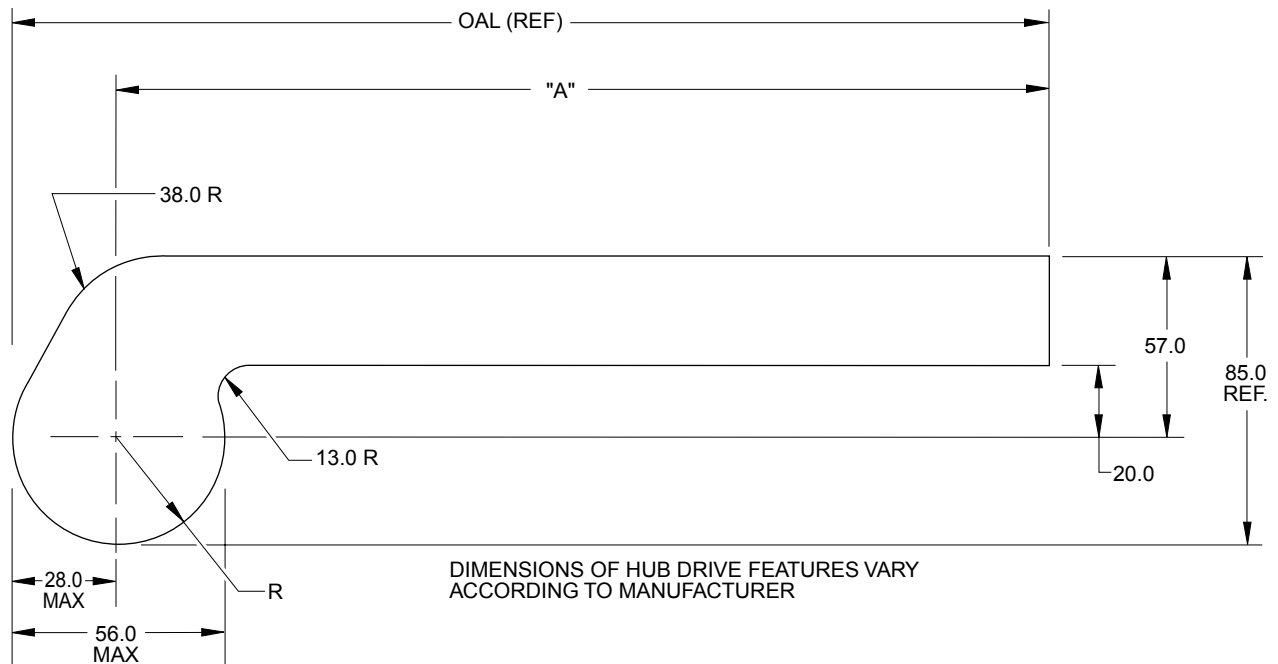

A

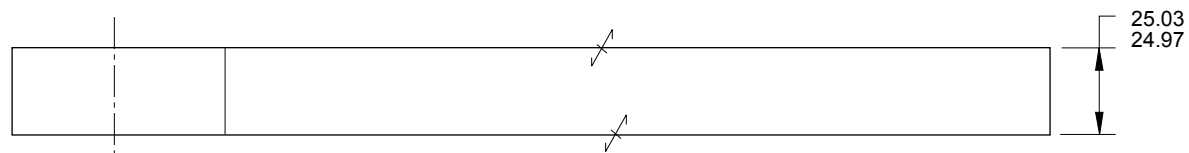

STAMP OR ETCH THE NAAMS CODE NUMBER AND THE CLAMP ARM MANUFACTURER'S NUMBER, IF DIFFERENT, ON THE SIDE OF THE ARM.

EXCEPT AS NOTED TOLERANCES SHALL BE:

- 1 PLACE MACHINING  $\pm 0.3$
- 1 PLACE FABRICATION  $\pm 1.5$

MATERIAL: SAE 4140 or SAE 1045

NOTES: ALL DIMENSIONS METRIC UNLESS OTHERWISE NOTED

C

NAAMS CODE	DIM. "A"	MAX OAL (REF)	WEIGHT kg
ACA013M	135.0	163.0	1.3
ACA014M	165.0	193.0	1.6
ACA015M	195.0	223.0	1.8
ACA016M	225.0	253.0	2.0
ACA017M	255.0	283.0	2.2
ACA018M	285.0	313.0	2.4

B

# POWER CLAMP ARMS BLANKS 60 SERIES

(65mm OFFSET) (FULL METRIC)

GLOBAL STANDARD COMPONENTS



Assembly

11/10/10

D

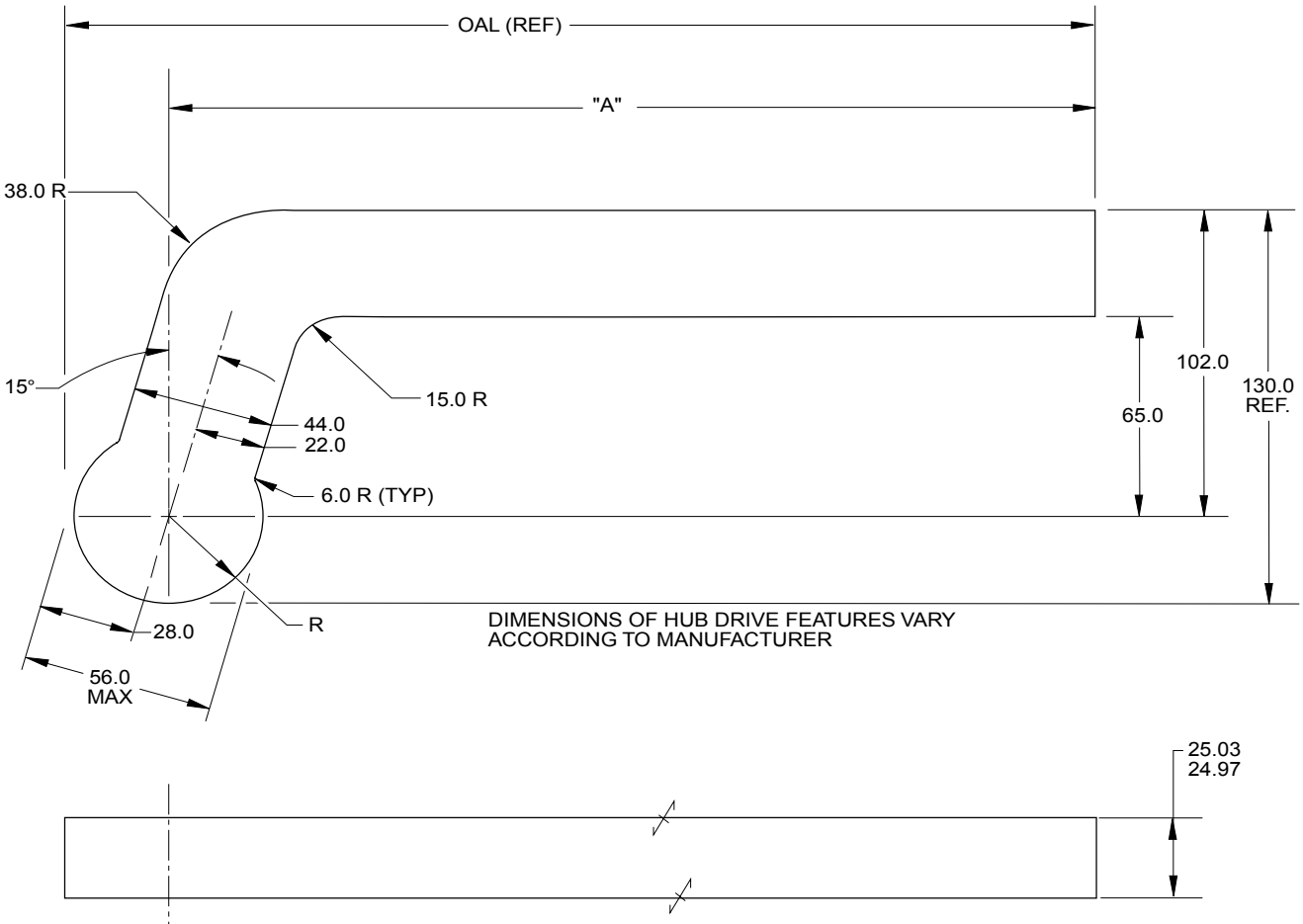

A

STAMP OR ETCH THE NAAMS CODE NUMBER AND THE CLAMP ARM MANUFACTURER'S NUMBER, IF DIFFERENT, ON THE SIDE OF THE ARM.

EXCEPT AS NOTED TOLERANCES SHALL BE:

- 1 PLACE MACHINING  $\pm 0.3$
- 1 PLACE FABRICATION  $\pm 1.5$

MATERIAL: SAE 4140 or SAE 1045

NOTES: ALL DIMENSIONS METRIC UNLESS OTHERWISE NOTED.

NAAMS CODE	DIM. "A"	MAX OAL (REF)	WEIGHT kg
ACA025M	135.0	163.0	1.7
ACA026M	165.0	193.0	1.9
ACA027M	195.0	223.0	2.1
ACA028M	225.0	253.0	2.4
ACA029M	255.0	283.0	2.6
ACA030M	285.0	313.0	2.8

C

B



# POWER CLAMP ARMS BLANKS 60 SERIES

(115mm OFFSET) (FULL METRIC)

GLOBAL STANDARD COMPONENTS



Assembly

11/10/10

D

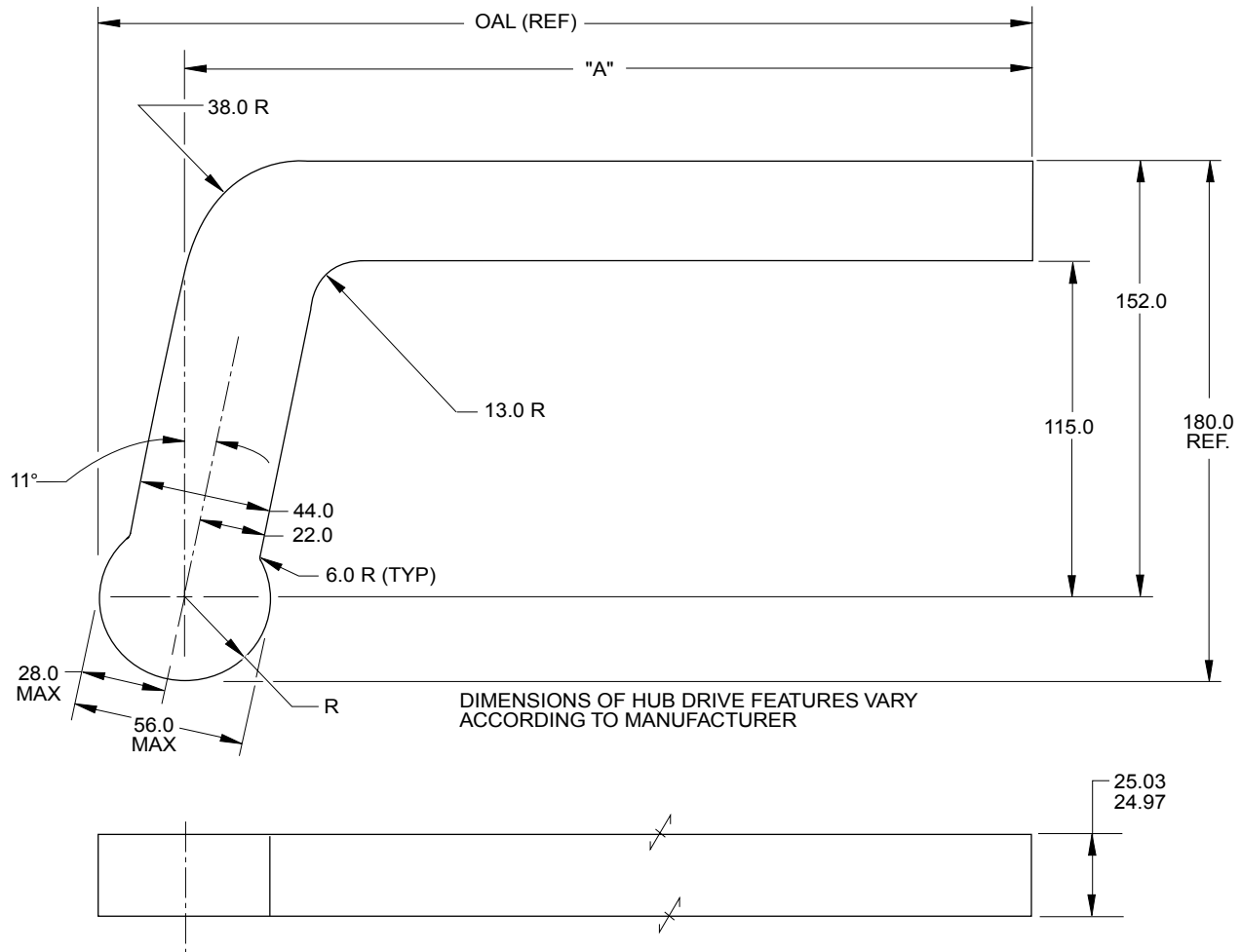

A

STAMP OR ETCH THE NAAMS CODE NUMBER AND THE CLAMP ARM MANUFACTURER'S NUMBER, IF DIFFERENT, ON THE SIDE OF THE ARM.

EXCEPT AS NOTED TOLERANCES SHALL BE:

- 1 PLACE MACHINING  $\pm 0.3$
- 1 PLACE FABRICATION  $\pm 1.5$

MATERIAL: SAE 4140 or SAE 1045

NOTES: ALL DIMENSIONS METRIC UNLESS OTHERWISE NOTED

C

NAAMS CODE	DIM. "A"	MAX OAL (REF)	WEIGHT kg
ACA037M	135.0	163.0	2.1
ACA038M	165.0	193.0	2.3
ACA039M	195.0	223.0	2.5
ACA040M	225.0	253.0	2.7
ACA041M	255.0	283.0	2.9
ACA042M	285.0	313.0	3.2

B

# POWER CLAMP ARMS 60 SERIES

(STRAIGHT - MACHINED) (FULL METRIC)

G

E

A

C

D

F

B

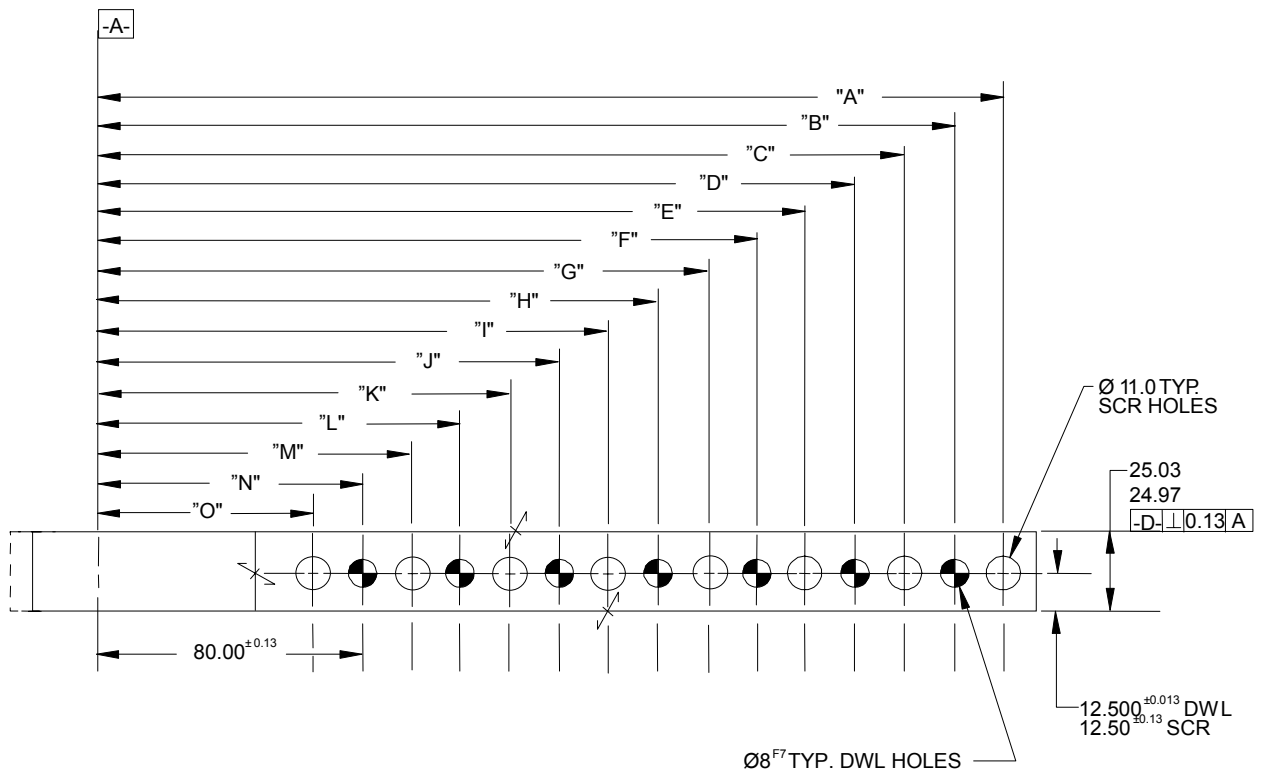
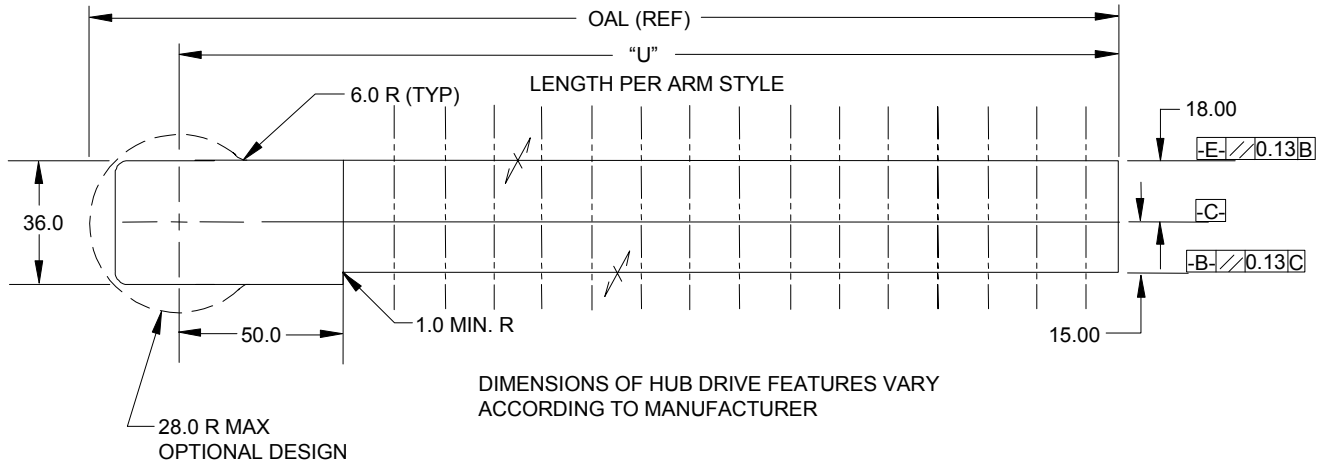

STAMP OR ETCH THE NAAMS CODE NUMBER AND THE CLAMP ARM MANUFACTURER'S NUMBER, IF DIFFERENT, ON THE SIDE OF THE ARM.

PAINT AS PRESCRIBED ON PAGE G-1.2

CLEARANCE HOLES G, I, K, M AND O ARE OPTIONAL UNTIL FEBRUARY 1, 2006 AND MANDATORY THEREAFTER.

TABULATED INFORMATION ON FOLLOWING PAGE

# POWER CLAMP ARMS 60 SERIES

(STRAIGHT - MACHINED) (FULL METRIC)

F

EXCEPT AS NOTED TOLERANCES SHALL BE:

- 1 PLACE MACHINING ±0.3
- 1 PLACE FABRICATION ±1.5
- 2 PLACE ±0.03 GENERAL
- ±0.03 BETWEEN DOWELS
- ±0.13 TO SCREW HOLES

NOTES: ALL DIMENSIONS METRIC UNLESS OTHERWISE NOTED.

MATERIAL: SAE 4140 or SAE 1045

E

NAAMS CODE	DIM "U" +1.5/-0.0	MAX OAL (REF)	Weight kg*	Dim. "A"	Dim. "B"	Dim. "C"	Dim. "D"	Dim. "E"	Dim. "F"	Dim. "G"	Dim. "H"	Dim. "I"	Dim. "J"	Dim. "K"	Dim. "L"	Dim. "M"
ACA007M	135.0	163.0	1.0	125.00	110.00	95.00	80.00	65.00								
ACA008M	165.0	193.0	1.2	155.00	140.00	125.00	110.00	95.00	80.00	65.00						
ACA009M	195.0	223.0	1.3	185.00	170.00	155.00	140.00	125.00	110.00	95.00	80.00	65.00				
ACA010M	225.0	253.0	1.4	215.00	200.00	185.00	170.00	155.00	140.00	125.00	110.00	95.00	80.00	65.00		
ACA011M	255.0	283.0	1.6	245.00	230.00	215.00	200.00	185.00	170.00	155.00	140.00	125.00	110.00	95.00	80.00	65.00
ACA012M	285.0	313.0	1.8	275.00	260.00	245.00	230.00	215.00	200.00	185.00	170.00	155.00	140.00	125.00	110.00	95.00

A

B

C



D

NAAMS CODE	Dim. "N"	Dim. "O"
ACA012M	80.00	65.00



\* Weight of arm as shown. Actual weight may vary due to variations in mounting details.

SEE DRAWING ON PREVIOUS PAGE

# POWER CLAMP ARMS 60 SERIES

(25mm OFFSET - MACHINED) (FULL METRIC)

GLOBAL STANDARD COMPONENTS



Assembly

11/10/10

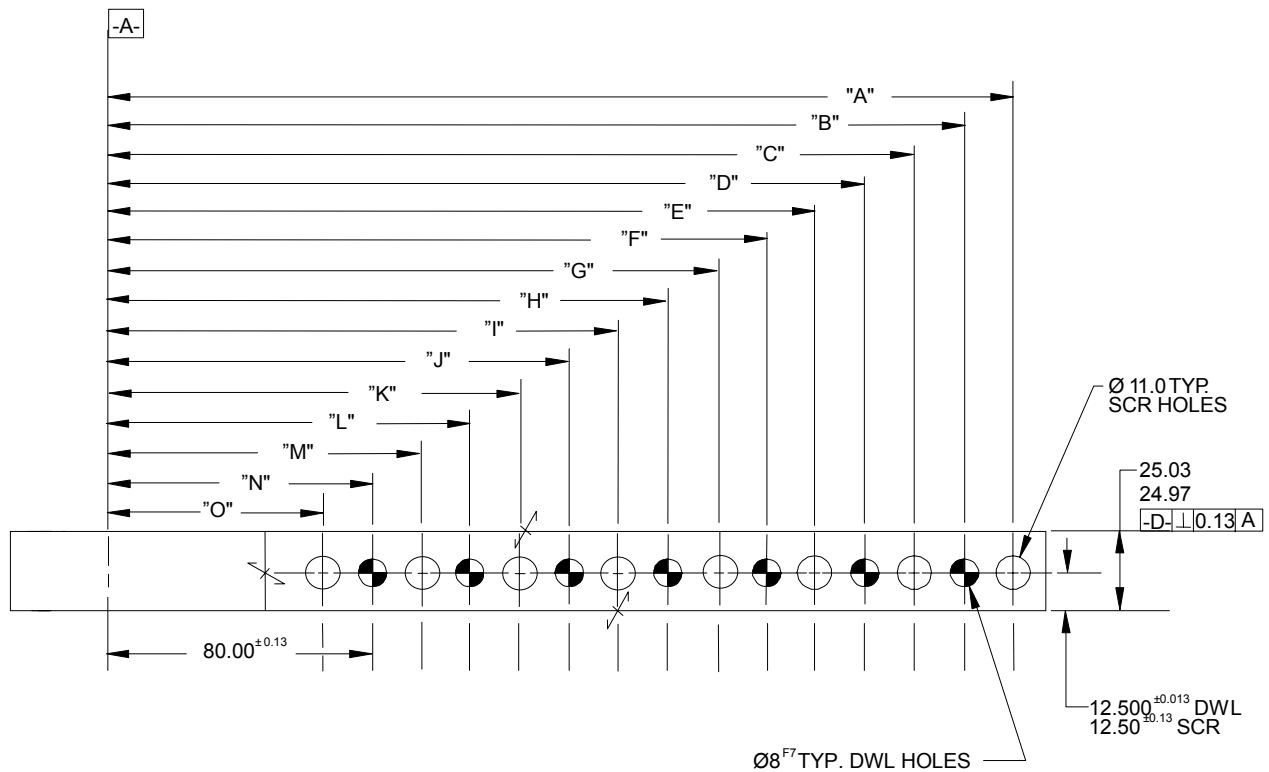
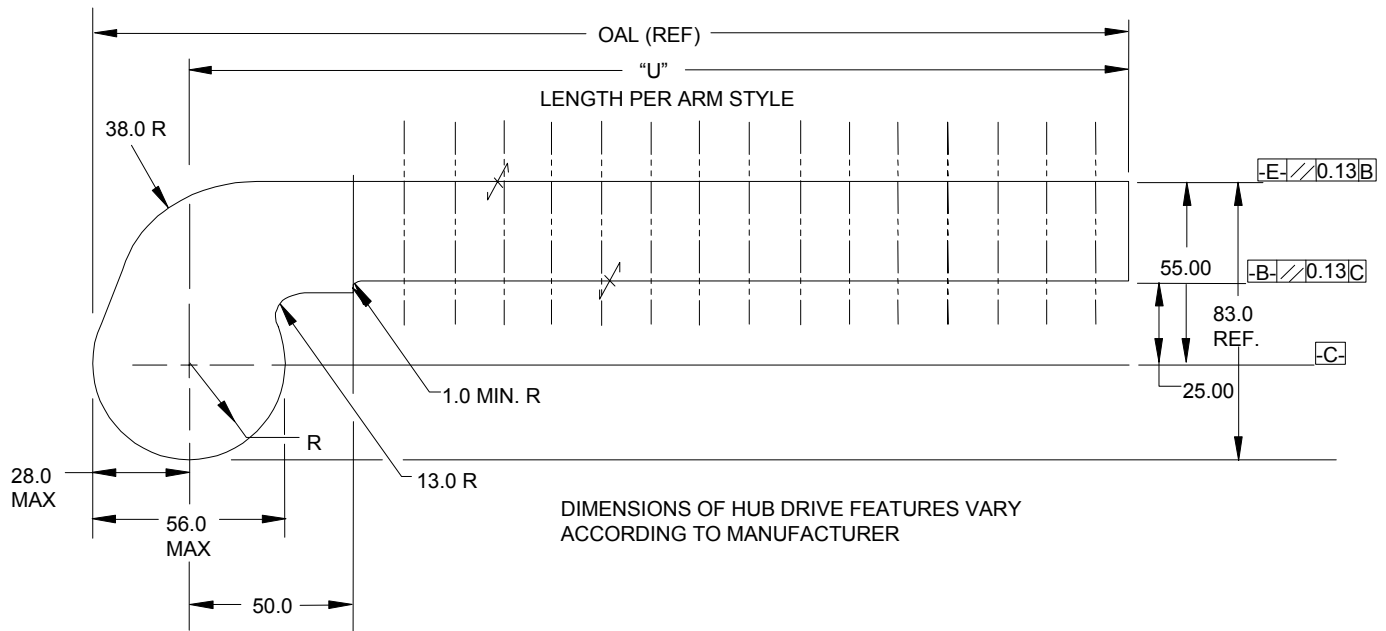

STAMP OR ETCH THE NAAMS CODE NUMBER AND THE CLAMP ARM MANUFACTURER'S NUMBER, IF DIFFERENT, ON THE SIDE OF THE ARM.

PAINT AS PRESCRIBED ON PAGE G-1.2

CLEARANCE HOLES G, I, K, M AND O ARE OPTIONAL UNTIL FEBRUARY 1, 2006 AND MANDATORY THEREAFTER.

TABULATED INFORMATION ON FOLLOWING PAGE

# POWER CLAMP ARMS 60 SERIES

(25mm OFFSET - MACHINED) (FULL METRIC)

GLOBAL STANDARD COMPONENTS



TM

Assembly

11/10/10

F

EXCEPT AS NOTED TOLERANCES SHALL BE:

- 1 PLACE MACHINING  $\pm 0.3$
- 1 PLACE FABRICATION  $\pm 1.5$
- 2 PLACE  $\pm 0.03$  GENERAL
  - $\pm 0.03$  BETWEEN DOWELS
  - $\pm 0.13$  TO SCREW HOLES

NOTES: ALL DIMENSIONS METRIC UNLESS OTHERWISE NOTED.

MATERIAL: SAE 4140 or SAE 1045

E

NAAMS CODE	DIM "U" +1.5/-0.0	MAX OAL (REF)	Weight kg*	Dim. "A"	Dim. "B"	Dim. "C"	Dim. "D"	Dim. "E"	Dim. "F"	Dim. "G"	Dim. "H"	Dim. "I"	Dim. "J"	Dim. "K"	Dim. "L"	Dim. "M"
ACA019M	135.0	163.0	1.1	125.00	110.00	95.00	80.00	65.00								
ACA020M	165.0	193.0	1.3	155.00	140.00	125.00	110.00	95.00	80.00	65.00						
ACA021M	195.0	223.0	1.4	185.00	170.00	155.00	140.00	125.00	110.00	95.00	80.00	65.00				
ACA022M	225.0	253.0	1.5	215.00	200.00	185.00	170.00	155.00	140.00	125.00	110.00	95.00	80.00	65.00		
ACA023M	255.0	283.0	1.6	245.00	230.00	215.00	200.00	185.00	170.00	155.00	140.00	125.00	110.00	95.00	80.00	65.00
ACA024M	285.0	313.0	1.9	275.00	260.00	245.00	230.00	215.00	200.00	185.00	170.00	155.00	140.00	125.00	110.00	95.00

A

B

C

DOWEL

D

NAAMS CODE	Dim. "N"	Dim. "O"
ACA024M	80.00	65.00

DOWEL

\* Weight of arm as shown. Actual weight may vary due to variations in mounting details.

SEE DRAWING ON PREVIOUS PAGE

# POWER CLAMP ARMS 60 SERIES

(70mm OFFSET - MACHINED) (FULL METRIC)

GLOBAL STANDARD COMPONENTS



Assembly

11/10/10

F

D

B

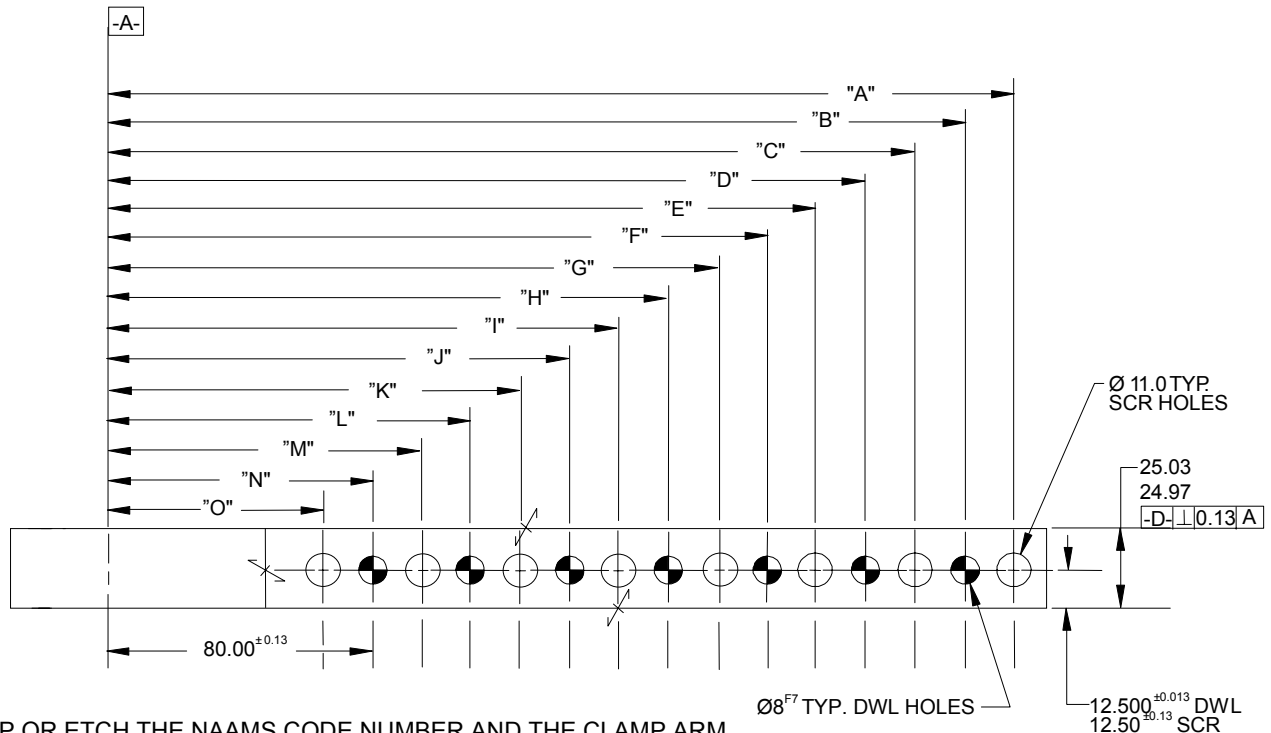
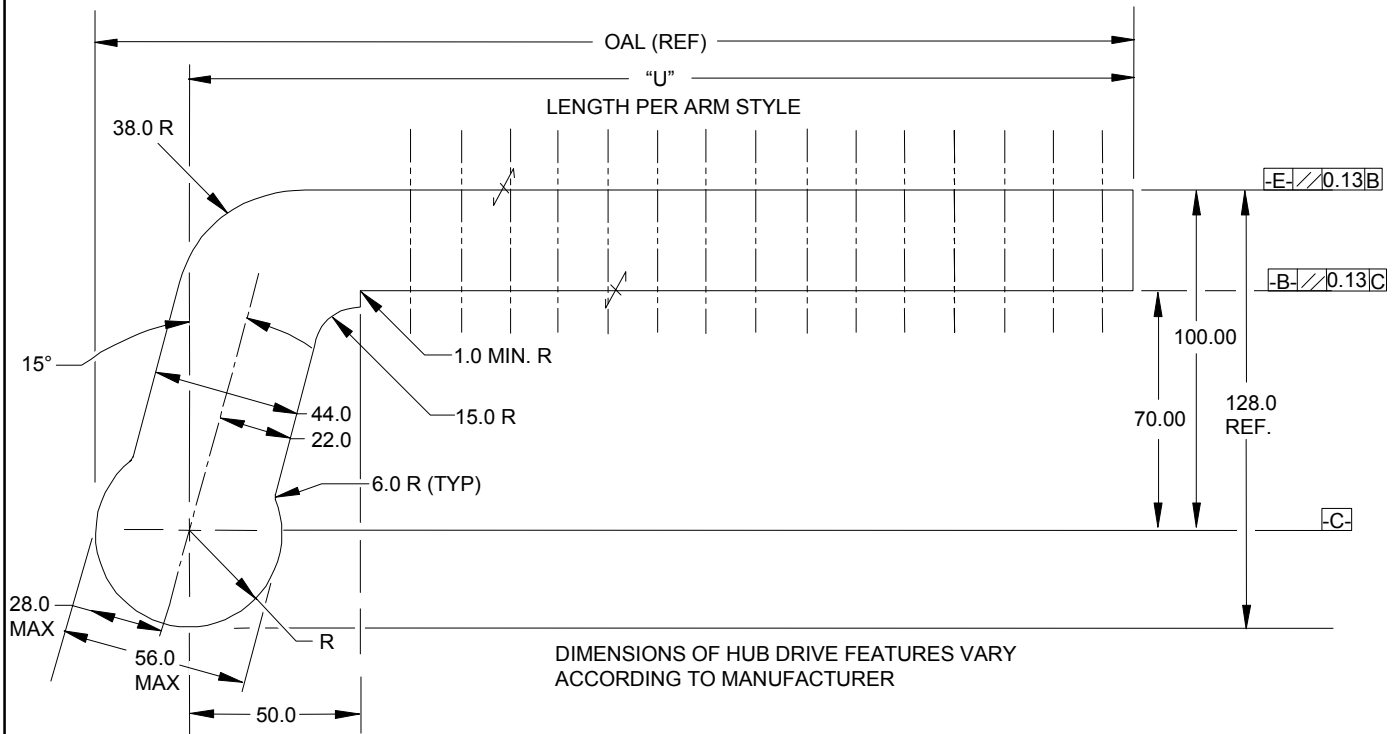

C

STAMP OR ETCH THE NAAMS CODE NUMBER AND THE CLAMP ARM MANUFACTURER'S NUMBER, IF DIFFERENT, ON THE SIDE OF THE ARM.

PAINT AS PRESCRIBED ON PAGE G-1.2

CLEARANCE HOLES G, I, K, M AND O ARE OPTIONAL UNTIL FEBRUARY 1, 2006 AND MANDATORY THEREAFTER.

TABULATED INFORMATION ON FOLLOWING PAGE

E

A

# POWER CLAMP ARMS 60 SERIES

(70mm OFFSET - MACHINED) (FULL METRIC)

GLOBAL STANDARD COMPONENTS



Assembly

11/10/10

F

EXCEPT AS NOTED TOLERANCES SHALL BE:

- 1 PLACE MACHINING  $\pm 0.3$
- 1 PLACE FABRICATION  $\pm 1.5$
- 2 PLACE  $\pm 0.03$  GENERAL
- $\pm 0.03$  BETWEEN DOWELS
- $\pm 0.13$  TO SCREW HOLES

NOTES: ALL DIMENSIONS METRIC UNLESS OTHERWISE NOTED.

MATERIAL: SAE 4140 or SAE 1045

E

NAAMS CODE	DIM "U" +1.5/-0.0	MAX OAL (REF)	Weight kg*	Dim. "A"	Dim. "B"	Dim. "C"	Dim. "D"	Dim. "E"	Dim. "F"	Dim. "G"	Dim. "H"	Dim. "I"	Dim. "J"	Dim. "K"	Dim. "L"	Dim. "M"
ACA031M	135.0	163.0	1.5	125.00	110.00	95.00	80.00	65.00								
ACA032M	165.0	193.0	1.7	155.00	140.00	125.00	110.00	95.00	80.00	65.00						
ACA033M	195.0	223.0	1.7	185.00	170.00	155.00	140.00	125.00	110.00	95.00	80.00	65.00				
ACA034M	225.0	253.0	1.9	215.00	200.00	185.00	170.00	155.00	140.00	125.00	110.00	95.00	80.00	65.00		
ACA035M	255.0	283.0	2.0	245.00	230.00	215.00	200.00	185.00	170.00	155.00	140.00	125.00	110.00	95.00	80.00	65.00
ACA036M	285.0	313.0	2.2	275.00	260.00	245.00	230.00	215.00	200.00	185.00	170.00	155.00	140.00	125.00	110.00	95.00

A

B

C



D

NAAMS CODE	Dim. "N"	Dim. "O"
ACA036M	80.00	65.00



\* Weight of arm as shown. Actual weight may vary due to variations in mounting details.

SEE DRAWING ON PREVIOUS PAGE

# POWER CLAMP ARMS 60 SERIES

(120mm OFFSET - MACHINED) (FULL METRIC)

GLOBAL STANDARD COMPONENTS



Assembly

11/10/10

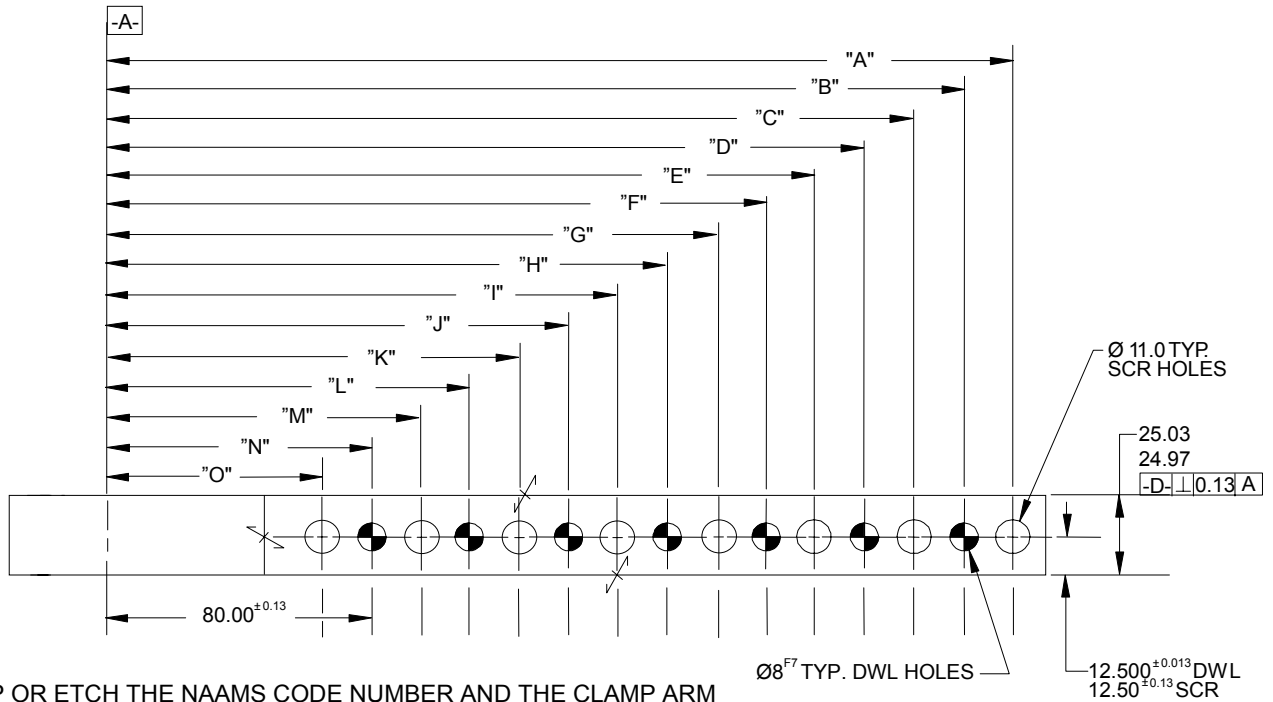
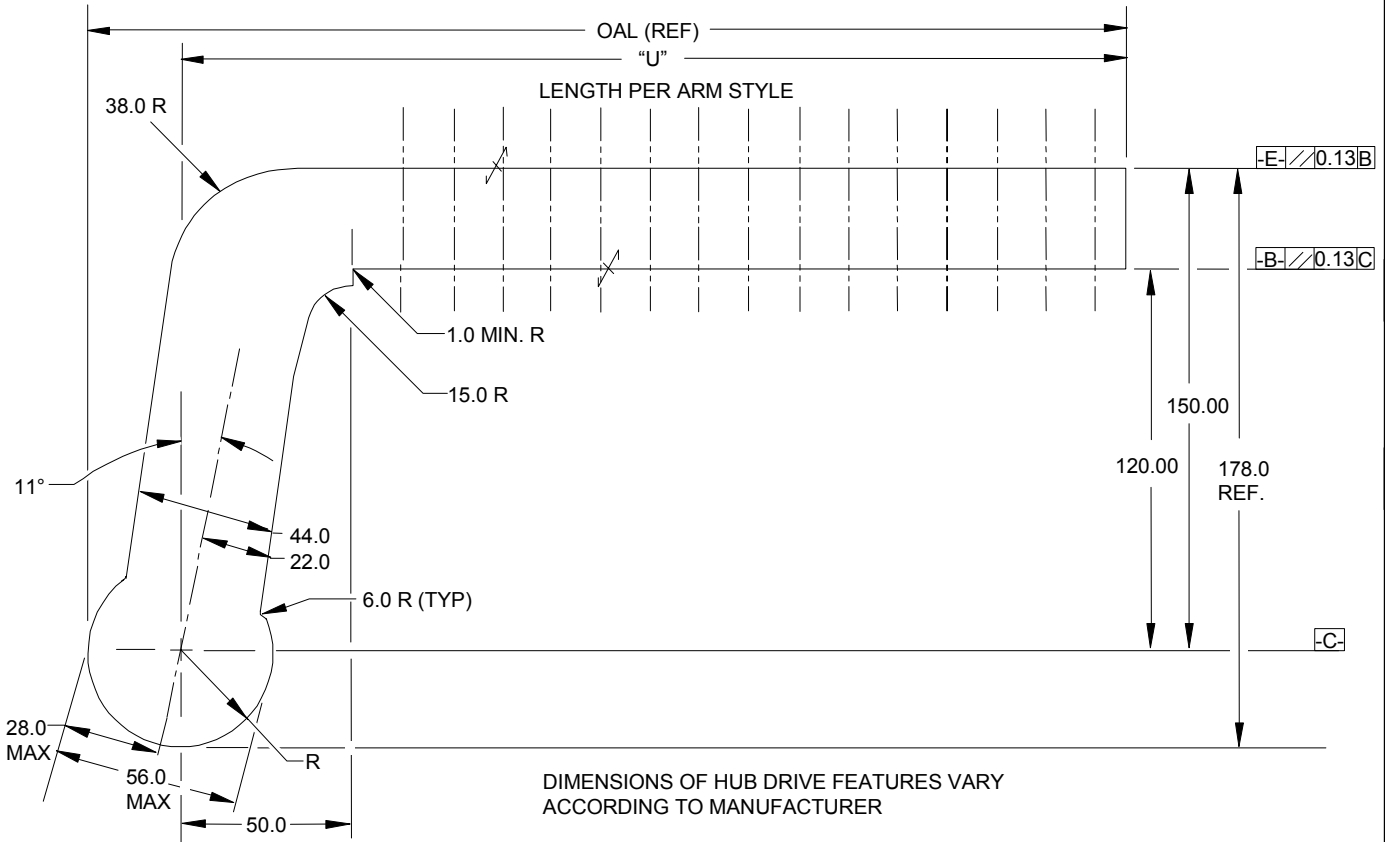

STAMP OR ETCH THE NAAMS CODE NUMBER AND THE CLAMP ARM MANUFACTURER'S NUMBER, IF DIFFERENT, ON THE SIDE OF THE ARM.

PAINT AS PRESCRIBED ON PAGE G-1.2

CLEARANCE HOLES G, I, K, M AND O ARE OPTIONAL UNTIL FEBRUARY 1, 2006 AND MANDATORY THEREAFTER.

TABULATED INFORMATION ON FOLLOWING PAGE



# POWER CLAMP ARMS 60 SERIES

(120mm OFFSET - MACHINED) (FULL METRIC)

GLOBAL STANDARD COMPONENTS



TM

Assembly

11/10/10

F

EXCEPT AS NOTED TOLERANCES SHALL BE:

- 1 PLACE MACHINING  $\pm 0.3$
- 1 PLACE FABRICATION  $\pm 1.5$
- 2 PLACE  $\pm 0.03$  GENERAL
  - $\pm 0.03$  BETWEEN DOWELS
  - $\pm 0.13$  TO SCREW HOLES

NOTES: ALL DIMENSIONS METRIC UNLESS OTHERWISE NOTED.

MATERIAL: SAE 4140 or SAE 1045

E

NAAMS CODE	DIM "U" +1.5/-0.0	MAX OAL (REF)	Weight kg*	Dim. "A"	Dim. "B"	Dim. "C"	Dim. "D"	Dim. "E"	Dim. "F"	Dim. "G"	Dim. "H"	Dim. "I"	Dim. "J"	Dim. "K"	Dim. "L"	Dim. "M"
ACA043M	135.0	163.0	1.9	125.00	110.00	95.00	80.00	65.00								
ACA044M	165.0	193.0	2.0	155.00	140.00	125.00	110.00	95.00	80.00	65.00						
ACA045M	195.0	223.0	2.1	185.00	170.00	155.00	140.00	125.00	110.00	95.00	80.00	65.00				
ACA046M	225.0	253.0	2.2	215.00	200.00	185.00	170.00	155.00	140.00	125.00	110.00	95.00	80.00	65.00		
ACA047M	255.0	283.0	2.4	245.00	230.00	215.00	200.00	185.00	170.00	155.00	140.00	125.00	110.00	95.00	80.00	65.00
ACA048M	285.0	313.0	2.6	275.00	260.00	245.00	230.00	215.00	200.00	185.00	170.00	155.00	140.00	125.00	110.00	95.00

A

B

C



D

NAAMS CODE	Dim. "N"	Dim. "O"
ACA048M	80.00	65.00

DOWEL

\* Weight of arm as shown. Actual weight may vary due to variations in mounting details.

SEE DRAWING ON PREVIOUS PAGE

# POWER CLAMP ARMS BLANKS 80/90 SERIES

GLOBAL STANDARD COMPONENTS



(STRAIGHT) (INCH AND METRIC DESIGNS)

Assembly

11/10/10

D

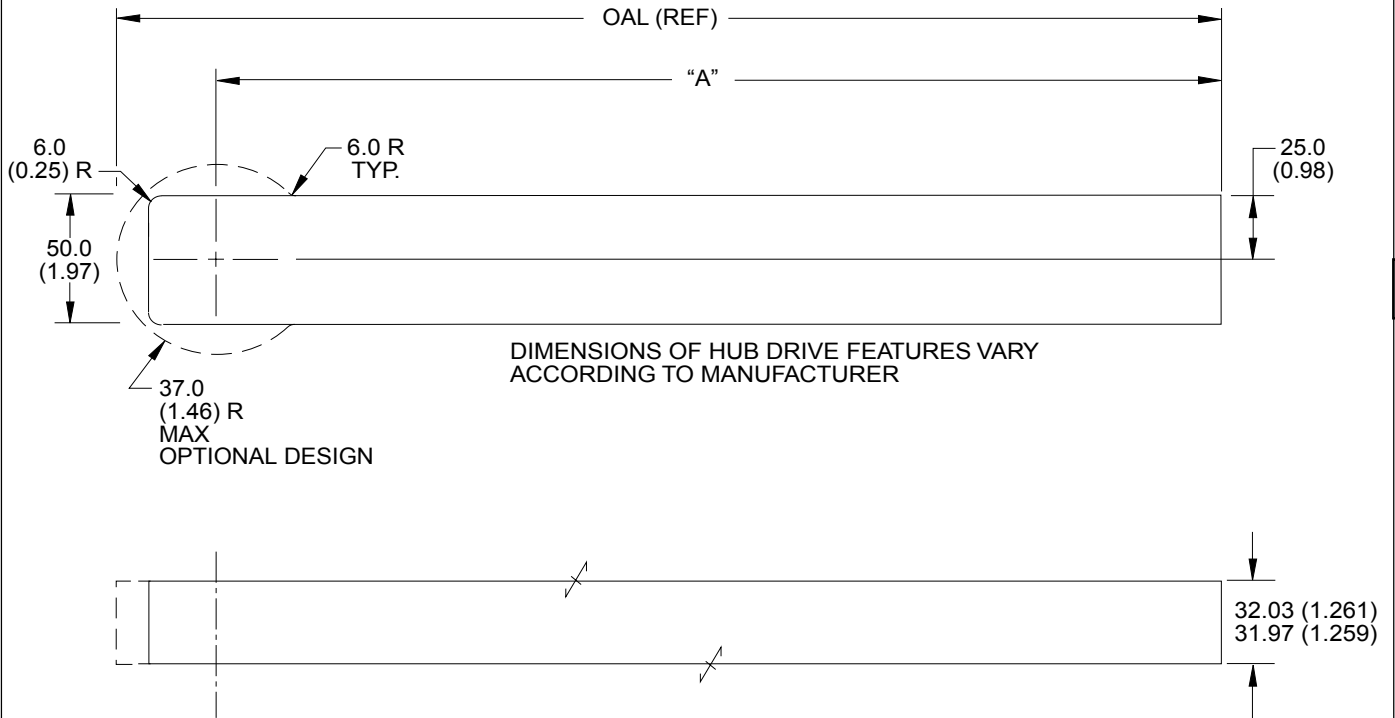

A

STAMP OR ETCH THE NAAMS CODE NUMBER AND THE CLAMP ARM MANUFACTURER'S NUMBER, IF DIFFERENT, ON THE SIDE OF THE ARM.

EXCEPT AS NOTED METRIC TOLERANCES SHALL BE:

- 1 PLACE MACHINING  $\pm 0.3$
- 1 PLACE FABRICATION  $\pm 1.5$

MATERIAL: SAE 4140 or SAE 1045

NOTES: ALL DIMENSIONS METRIC UNLESS OTHERWISE NOTED.  
DIMENSIONS IN PARENTHESES ARE INCH EQUIVALENT.

C

NAAMS CODE	DIM. "A"	MAX OAL (REF)	WEIGHT kg (lb)
ACA100M	155.0 (6.10)	192.0 (7.56)	2.1 (4.6)
ACA101M	185.0 (7.28)	222.0 (8.74)	2.5 (5.5)
ACA102M	215.0 (8.46)	252.0 (9.92)	2.9 (6.4)
ACA103M	245.0 (9.65)	282.0 (11.10)	3.2 (7.1)
ACA104M	275.0 (10.83)	312.0 (12.28)	3.6 (7.9)
ACA105M	305.0 (12.00)	342.0 (13.46)	4.0 (8.8)
ACA106M	335.0 (13.19)	372.0 (14.65)	4.4 (9.7)
ACA107M	365.0 (14.37)	402.0 (15.83)	4.7 (10.4)
ACA108M	395.0 (15.55)	432.0 (17.01)	5.1 (11.2)

B

# POWER CLAMP ARMS BLANKS 80/90 SERIES

GLOBAL STANDARD COMPONENTS



(20mm OFFSET) (INCH AND METRIC DESIGNS)

Assembly

11/10/10

D

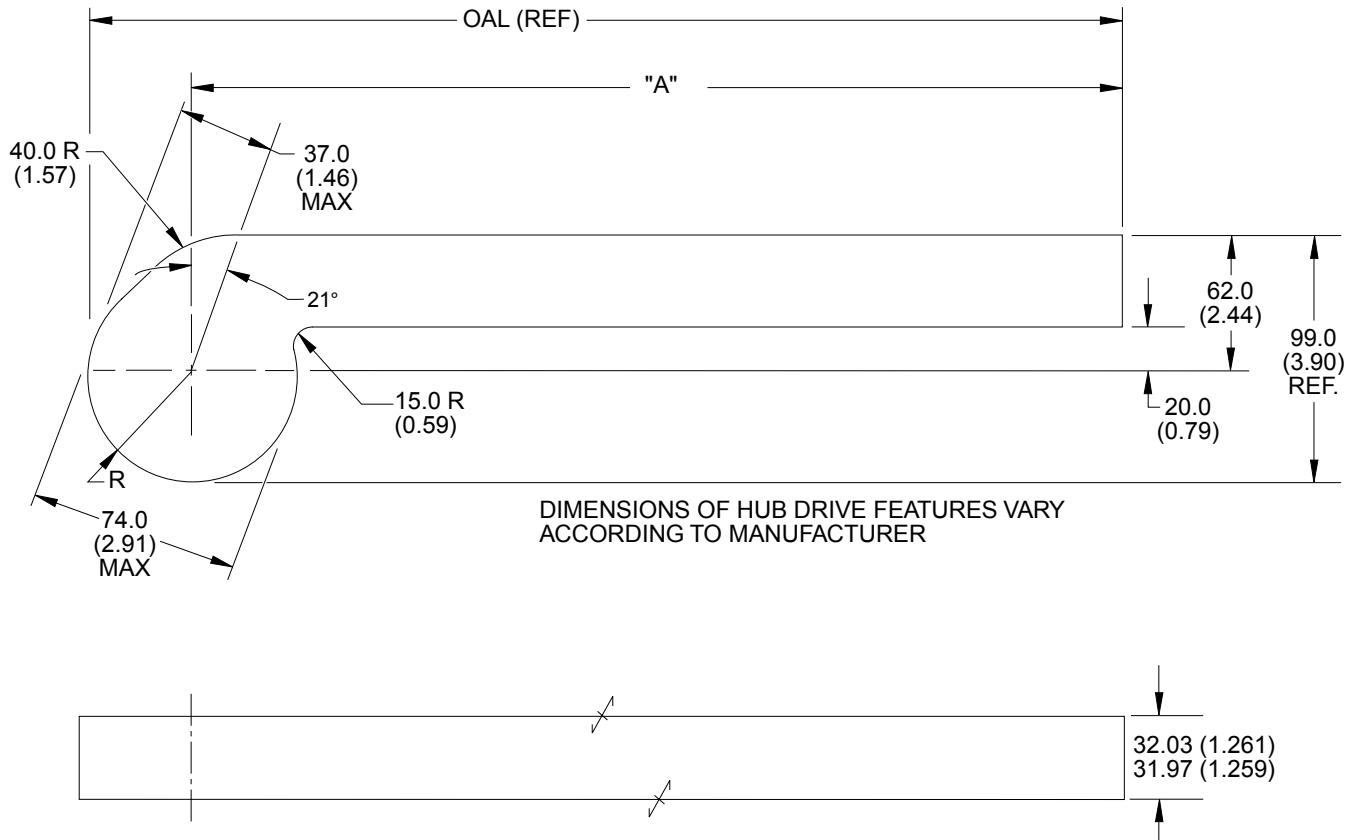

A

STAMP OR ETCH THE NAAMS CODE NUMBER AND THE CLAMP ARM MANUFACTURER'S NUMBER, IF DIFFERENT, ON THE SIDE OF THE ARM.

EXCEPT AS NOTED METRIC TOLERANCES SHALL BE:

- 1 PLACE MACHINING  $\pm 0.3$
- 1 PLACE FABRICATION  $\pm 1.5$

MATERIAL: SAE 4140 or SAE 1045

NOTES: ALL DIMENSIONS METRIC UNLESS OTHERWISE NOTED.  
DIMENSIONS IN PARENTHESES ARE INCH EQUIVALENT.

C

NAAMS CODE	DIM. "A"	MAX OAL (REF)	WEIGHT kg (lb)
ACA120M	155.0 (6.10)	192.0 (7.56)	2.4 (5.3)
ACA121M	185.0 (7.28)	222.0 (8.74)	2.7 (6.0)
ACA122M	215.0 (8.46)	252.0 (9.92)	3.0 (6.6)
ACA123M	245.0 (9.65)	282.0 (11.10)	3.3 (7.3)
ACA124M	275.0 (10.83)	312.0 (12.28)	3.6 (7.9)
ACA125M	305.0 (12.00)	342.0 (13.46)	3.9 (8.6)
ACA126M	335.0 (13.19)	372.0 (14.65)	4.2 (9.3)
ACA127M	365.0 (14.37)	402.0 (15.83)	4.6 (10.1)
ACA128M	395.0 (15.55)	432.0 (17.01)	4.9 (10.8)

B

# POWER CLAMP ARMS BLANKS 80/90 SERIES

GLOBAL STANDARD COMPONENTS



(65mm OFFSET) (INCH AND METRIC DESIGNS)

Assembly

11/10/10

D

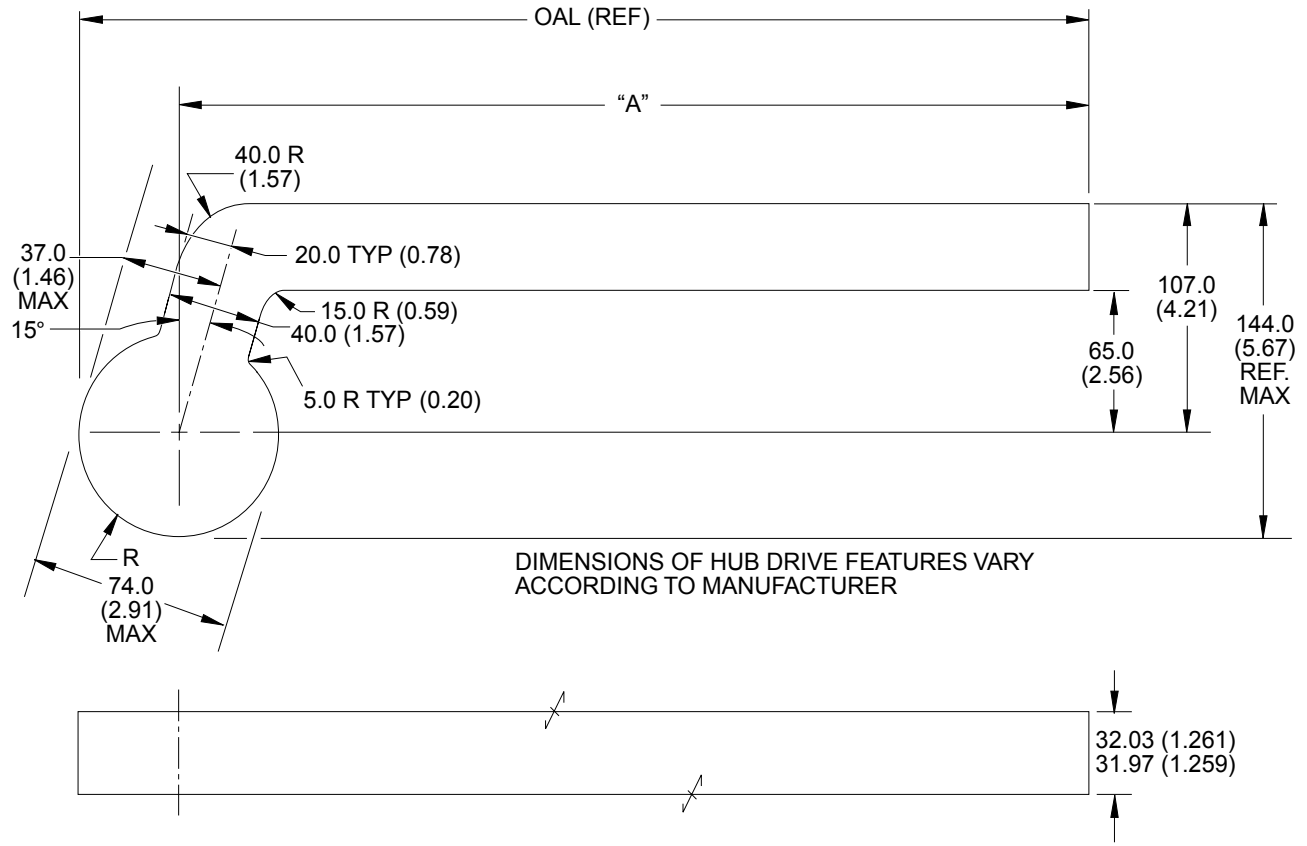

A

STAMP OR ETCH THE NAAMS CODE NUMBER AND THE CLAMP ARM MANUFACTURER'S NUMBER, IF DIFFERENT, ON THE SIDE OF THE ARM.

EXCEPT AS NOTED METRIC TOLERANCES SHALL BE:

- 1 PLACE MACHINING  $\pm 0.3$
- 1 PLACE FABRICATION  $\pm 1.5$

MATERIAL: SAE 4140 or SAE 1045

NOTES: ALL DIMENSIONS METRIC UNLESS OTHERWISE NOTED.  
DIMENSIONS IN PARENTHESES ARE INCH EQUIVALENT.

C

NAAMS CODE	DIM. "A"	MAX OAL (REF)	WEIGHT kg (lb)
ACA140M	155.0 (6.10)	192.0 (7.56)	2.7 (6.0)
ACA141M	185.0 (7.28)	222.0 (8.74)	3.0 (6.6)
ACA142M	215.0 (8.46)	252.0 (9.92)	3.3 (7.3)
ACA143M	245.0 (9.65)	282.0 (11.10)	3.6 (7.9)
ACA144M	275.0 (10.83)	312.0 (12.28)	3.9 (8.6)
ACA145M	305.0 (12.00)	342.0 (13.46)	4.2 (9.3)
ACA146M	335.0 (13.19)	372.0 (14.65)	4.5 (9.9)
ACA147M	365.0 (14.37)	402.0 (15.83)	4.9 (10.8)
ACA148M	395.0 (15.55)	432.0 (17.01)	5.1 (11.2)

B

# POWER CLAMP ARMS BLANKS 80/90 SERIES

GLOBAL STANDARD COMPONENTS



(115mm OFFSET) (INCH AND METRIC DESIGNS)

Assembly

11/10/10

D

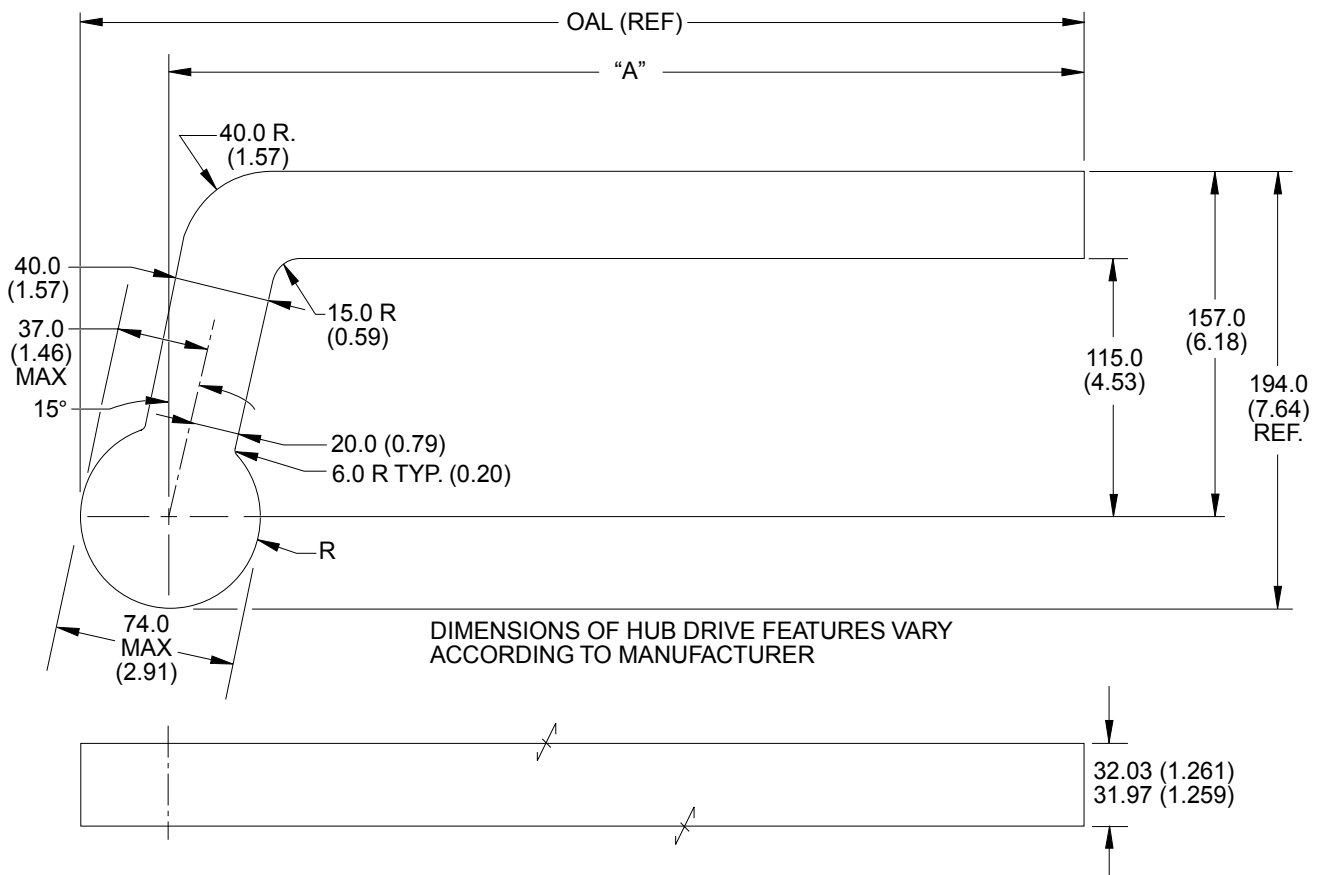

A

STAMP OR ETCH THE NAAMS CODE NUMBER AND THE CLAMP ARM MANUFACTURER'S NUMBER, IF DIFFERENT, ON THE SIDE OF THE ARM.

EXCEPT AS NOTED METRIC TOLERANCES SHALL BE:

- 1 PLACE MACHINING  $\pm 0.3$
- 1 PLACE FABRICATION  $\pm 1.5$

MATERIAL: SAE 4140 or SAE 1045

NOTES: ALL DIMENSIONS METRIC UNLESS OTHERWISE NOTED.  
DIMENSIONS IN PARENTHESES ARE INCH EQUIVALENT.

C

NAAMS CODE	DIM. "A"	MAX OAL (REF)	WEIGHT kg (lb)
ACA160M	155.0 (6.10)	192.0 (7.56)	3.0 (6.6)
ACA161M	185.0 (7.28)	222.0 (8.74)	3.4 (7.5)
ACA162M	215.0 (8.46)	252.0 (9.92)	3.7 (8.2)
ACA163M	245.0 (9.65)	282.0 (11.10)	4.0 (8.8)
ACA164M	275.0 (10.83)	312.0 (12.28)	4.3 (9.5)
ACA165M	305.0 (12.00)	342.0 (13.46)	4.6 (10.1)
ACA166M	335.0 (13.19)	372.0 (14.65)	4.9 (10.8)
ACA167M	365.0 (14.37)	402.0 (15.83)	5.2 (11.5)
ACA168M	395.0 (15.55)	432.0 (17.01)	5.6 (12.3)

B

# POWER CLAMP ARMS 80/90 SERIES (STRAIGHT - MACHINED) (FULL METRIC)

E

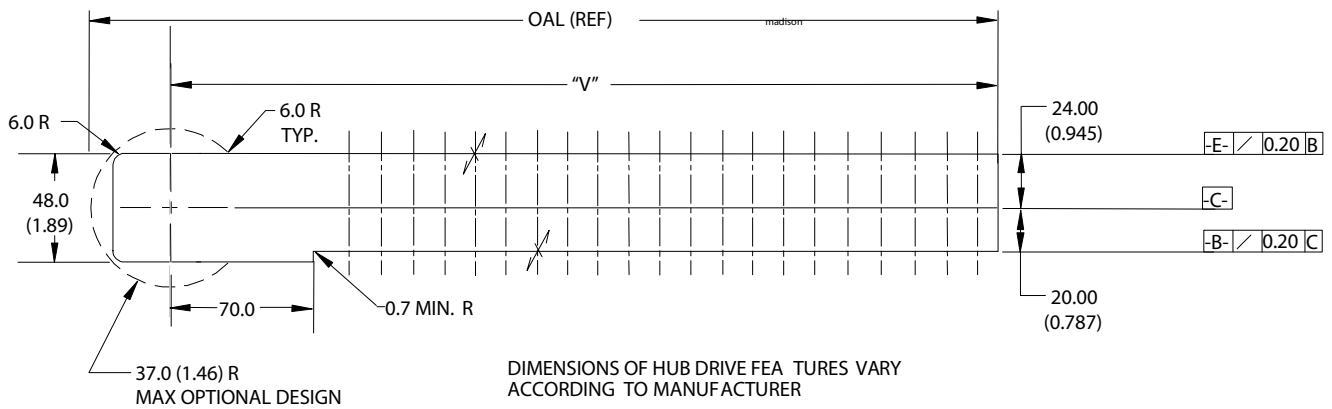

B

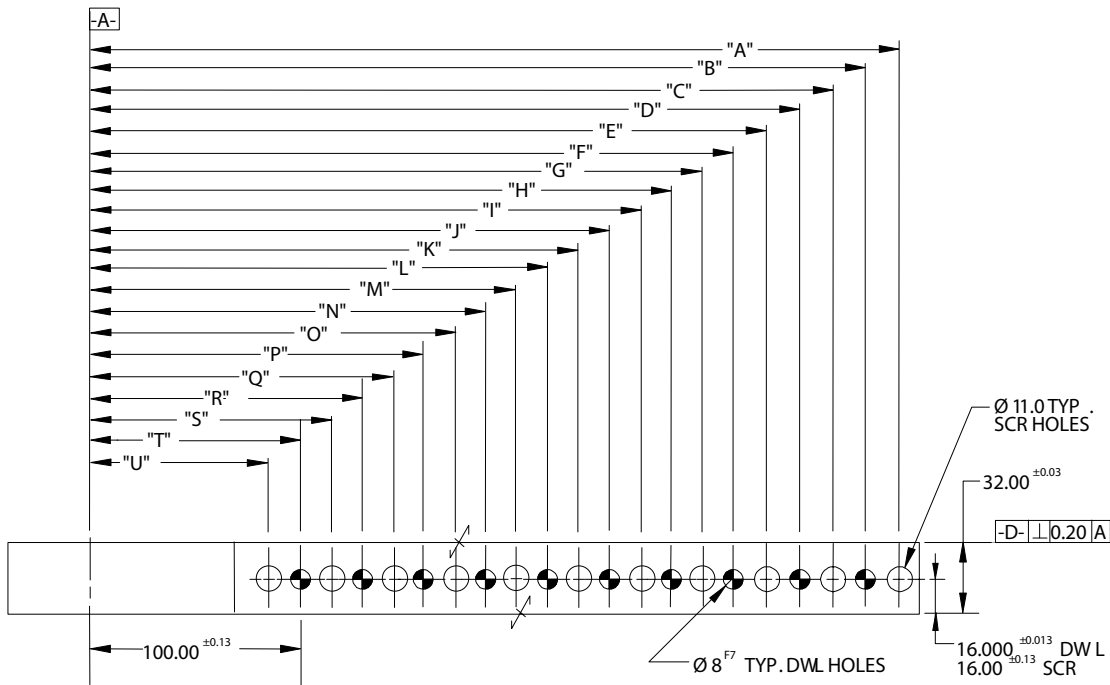

C

STAMP OR ETCH THE NAAMS CODE NUMBER AND THE CLAMP ARM MANUFACTURER'S NUMBER, IF DIFFERENT, ON THE SIDE OF THE ARM.

PAINT AS PRESCRIBED ON PAGE G-1.2

CLEARANCE HOLES G, I, K, M, O, Q, S AND U ARE OPTIONAL UNTIL FEBRUARY 1, 2006 AND MANDATORY THEREAFTER.

TABULATED INFORMATION ON FOLLOWING PAGE

D

A

# POWER CLAMP ARMS 80/90 SERIES

(STRAIGHT - MACHINED) (FULL METRIC)

GLOBAL STANDARD COMPONENTS



Assembly

11/10/10

H

MAXIMUM ALLOWABLE ROUGHNESS SHALL BE:  
 1 PLACE FINISH DIMENSIONS TO BE 6 MICRONS  
 2 PLACE FINISH DIMENSIONS TO BE 3 MICRONS  
 3 PLACE FINISH DIMENSIONS TO BE 1.6 MICRONS

EXCEPT AS NOTED TOLERANCES SHALL BE:

- 1 PLACE MACHINING  $\pm 0.3$
- 1 PLACE FABRICATION  $\pm 1.5$
- 2 PLACE  $\pm 0.03$  GENERAL  
 $\pm 0.03$  BETWEEN DOWELS  
 $\pm 0.13$  TO SCREW HOLES

NOTES: ALL DIMENSIONS METRIC UNLESS OTHERWISE NOTED.

MATERIAL: SAE 4140 or SAE 1045

G

NAAMS CODE	DIM "V" +1.5/-0.0	MAX OAL (REF)	Weight kg*	Dim. "A"	Dim. "B"	Dim. "C"	Dim. "D"	Dim. "E"	Dim. "F"	Dim. "G"	Dim. "H"	Dim. "I"	Dim. "J"	Dim. "K"	Dim. "L"	Dim. "M"
ACA110M	155.00	192.00	1.9	145.00	130.00	115.00	100.00	85.00								
ACA111M	185.00	222.00	2.2	175.00	160.00	145.00	130.00	115.00	100.00	85.00						
ACA112M	215.00	252.00	2.4	205.00	190.00	175.00	160.00	145.00	130.00	115.00	100.00	85.00				
ACA113M	245.00	282.00	2.7	235.00	220.00	205.00	190.00	175.00	160.00	145.00	130.00	115.00	100.00	85.00		
ACA114M	275.00	312.00	3.0	265.00	250.00	235.00	220.00	205.00	190.00	175.00	160.00	145.00	130.00	115.00	100.00	85.00
ACA115M	305.00	342.00	3.2	295.00	280.00	265.00	250.00	235.00	220.00	205.00	190.00	175.00	160.00	145.00	130.00	115.00
ACA116M	335.00	372.00	3.6	325.00	310.00	295.00	280.00	265.00	250.00	235.00	220.00	205.00	190.00	175.00	160.00	145.00
ACA117M	365.00	402.00	3.9	355.00	340.00	325.00	310.00	295.00	280.00	265.00	250.00	235.00	220.00	205.00	190.00	175.00
ACA118M	395.00	432.00	4.1	385.00	370.00	355.00	340.00	325.00	310.00	295.00	280.00	265.00	250.00	235.00	220.00	205.00

C

A

D

E

F

B

DOWEL

NAAMS CODE	Dim. "N"	Dim. "O"	Dim. "P"	Dim. "Q"	Dim. "R"	Dim. "S"	Dim. "T"	Dim. "U"
ACA115M	100.00	85.00						
ACA116M	130.00	115.00	100.00	85.00				
ACA117M	160.00	145.00	130.00	115.00	100.00	85.00		
ACA118M	190.00	175.00	160.00	145.00	130.00	115.00	100.00	85.00

DOWEL

\* Weight of arm as shown. Actual weight may vary due to variations in mounting details.

SEE DRAWING ON PREVIOUS PAGE

# POWER CLAMP ARMS 80/90 SERIES

(25mm OFFSET - MACHINED) (FULL METRIC)

GLOBAL STANDARD COMPONENTS



Assembly

11/10/10

E

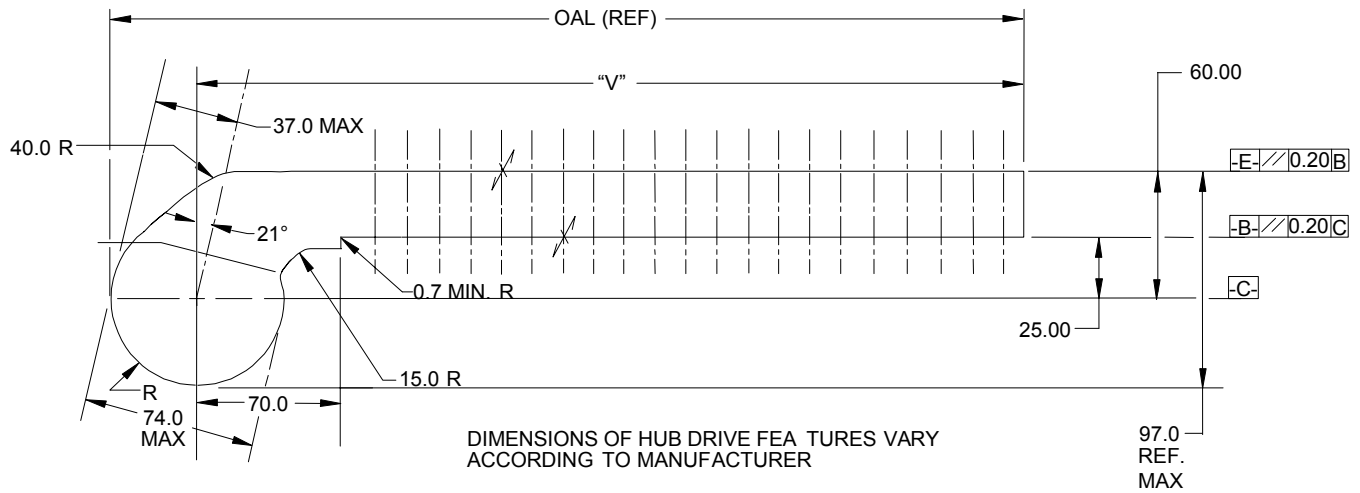

B

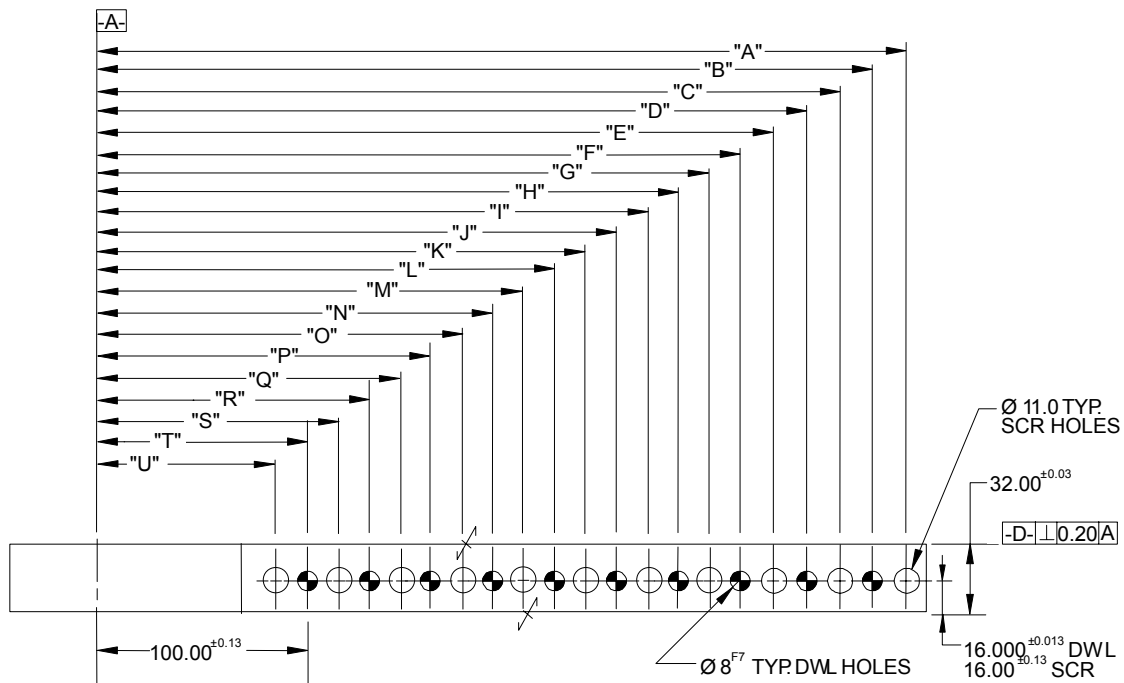

C

STAMP OR ETCH THE NAAMS CODE NUMBER AND THE CLAMP ARM MANUFACTURER'S NUMBER, IF DIFFERENT, ON THE SIDE OF THE ARM.

PAINT AS PRESCRIBED ON PAGE G-1.2

CLEARANCE HOLES G, I, K, M, O, Q, S AND U ARE OPTIONAL UNTIL FEBRUARY 1, 2006 AND MANDATORY THEREAFTER.

TABULATED INFORMATION ON FOLLOWING PAGE

D

A



# POWER CLAMP ARMS 80/90 SERIES

(25mm OFFSET - MACHINED) (FULL METRIC)

H

MAXIMUM ALLOWABLE ROUGHNESS SHALL BE:  
1 PLACE FINISH DIMENSIONS TO BE 6 MICRONS  
2 PLACE FINISH DIMENSIONS TO BE 3 MICRONS  
3 PLACE FINISH DIMENSIONS TO BE 1.6 MICRONS

EXCEPT AS NOTED TOLERANCES SHALL BE:

- 1 PLACE MACHINING ±0.3
- 1 PLACE FABRICATION ±1.5
- 2 PLACE ±0.03 GENERAL  
±0.03 BETWEEN DOWELS  
±0.13 TO SCREW HOLES

NOTES: ALL DIMENSIONS METRIC UNLESS OTHERWISE NOTED.

MATERIAL: SAE 4140 or SAE 1045

G

NAAMS CODE	DIM "V" +1.5/-0.0	MAX OAL (REF)	Weight kg*	Dim. "A"	Dim. "B"	Dim. "C"	Dim. "D"	Dim. "E"	Dim. "F"	Dim. "G"	Dim. "H"	Dim. "I"	Dim. "J"	Dim. "K"	Dim. "L"	Dim. "M"
ACA130M	155.00	192.00	2.1	145.00	130.00	115.00	100.00	85.00								
ACA131M	185.00	222.00	2.3	175.00	160.00	145.00	130.00	115.00	100.00	85.00						
ACA132M	215.00	252.00	2.5	205.00	190.00	175.00	160.00	145.00	130.00	115.00	100.00	85.00				
ACA133M	245.00	282.00	2.7	235.00	220.00	205.00	190.00	175.00	160.00	145.00	130.00	115.00	100.00	85.00		
ACA134M	275.00	312.00	3.0	265.00	250.00	235.00	220.00	205.00	190.00	175.00	160.00	145.00	130.00	115.00	100.00	85.00
ACA135M	305.00	342.00	3.2	295.00	280.00	265.00	250.00	235.00	220.00	205.00	190.00	175.00	160.00	145.00	130.00	115.00
ACA136M	335.00	372.00	3.4	325.00	310.00	295.00	280.00	265.00	250.00	235.00	220.00	205.00	190.00	175.00	160.00	145.00
ACA137M	365.00	402.00	3.6	355.00	340.00	325.00	310.00	295.00	280.00	265.00	250.00	235.00	220.00	205.00	190.00	175.00
ACA138M	395.00	432.00	3.9	385.00	370.00	355.00	340.00	325.00	310.00	295.00	280.00	265.00	250.00	235.00	220.00	205.00

C

A

D

E

F

B



NAAMS CODE	Dim. "N"	Dim. "O"	Dim. "P"	Dim. "Q"	Dim. "R"	Dim. "S"	Dim. "T"	Dim. "U"
ACA135M	100.00	85.00						
ACA136M	130.00	115.00	100.00	85.00				
ACA137M	160.00	145.00	130.00	115.00	100.00	85.00		
ACA138M	190.00	175.00	160.00	145.00	130.00	115.00	100.00	85.00



\* Weight of arm as shown. Actual weight may vary due to variations in mounting details.

SEE DRAWING ON PREVIOUS PAGE

# POWER CLAMP ARMS 80/90 SERIES

(70mm OFFSET - MACHINED) (FULL METRIC)

GLOBAL STANDARD COMPONENTS



Assembly

11/10/10

E

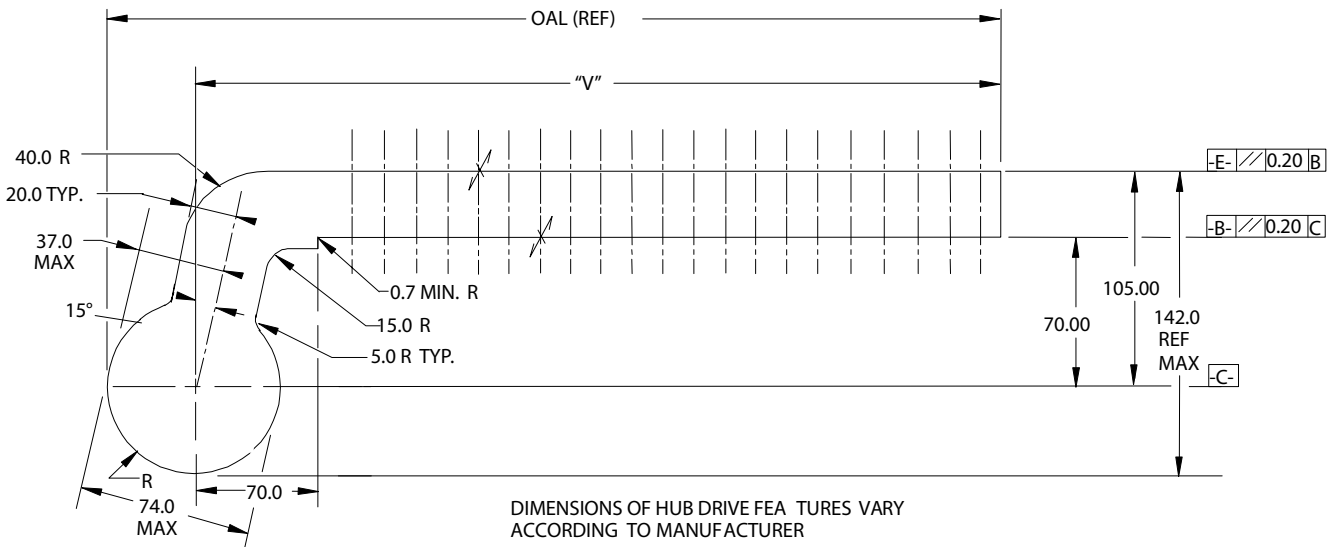

B

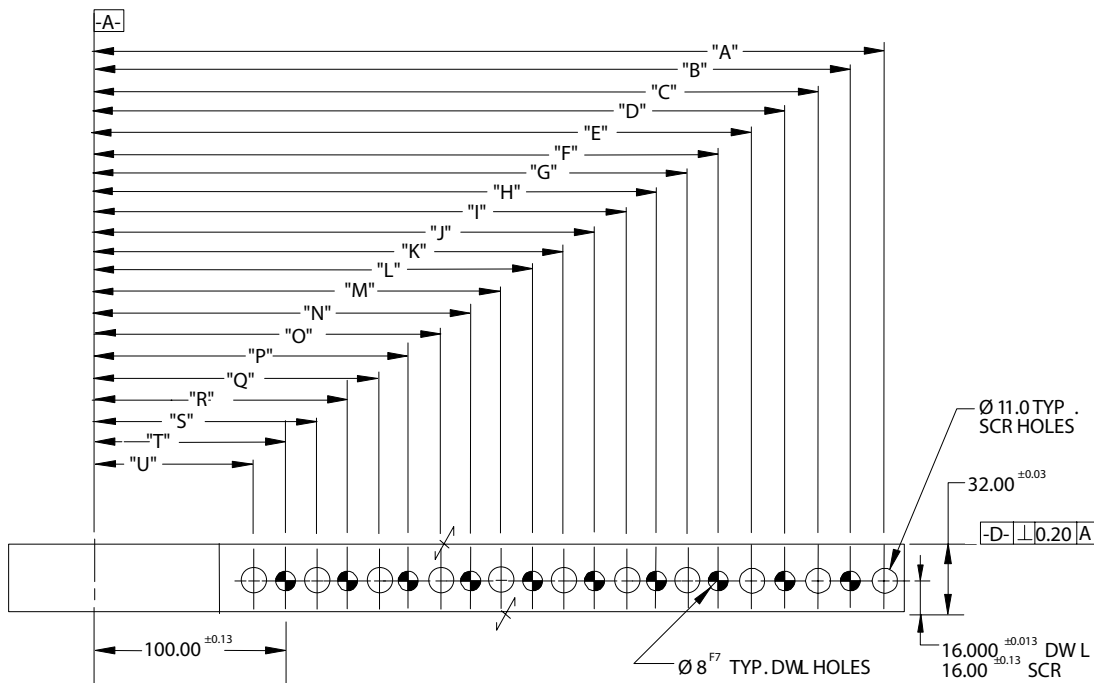

C

STAMP OR ETCH THE NAAMS CODE NUMBER AND THE CLAMP ARM MANUFACTURER'S NUMBER, IF DIFFERENT, ON THE SIDE OF THE ARM.

PAINT AS PRESCRIBED ON PAGE G-1.2

CLEARANCE HOLES G, I, K, M, O, Q, S AND U ARE OPTIONAL UNTIL FEBRUARY 1, 2006 AND MANDATORY THEREAFTER.

TABULATED INFORMATION ON FOLLOWING PAGE

D

A

# POWER CLAMP ARMS 80/90 SERIES

(70mm OFFSET - MACHINED) (FULL METRIC)

GLOBAL STANDARD COMPONENTS



Assembly

11/10/10

H

MAXIMUM ALLOWABLE ROUGHNESS SHALL BE:  
 1 PLACE FINISH DIMENSIONS TO BE 6 MICRONS  
 2 PLACE FINISH DIMENSIONS TO BE 3 MICRONS  
 3 PLACE FINISH DIMENSIONS TO BE 1.6 MICRONS

EXCEPT AS NOTED TOLERANCES SHALL BE:

- 1 PLACE MACHINING  $\pm 0.3$
- 1 PLACE FABRICATION  $\pm 1.5$
- 2 PLACE  $\pm 0.03$  GENERAL  
 $\pm 0.03$  BETWEEN DOWELS  
 $\pm 0.13$  TO SCREW HOLES

NOTES: ALL DIMENSIONS METRIC UNLESS OTHERWISE NOTED.

MATERIAL: SAE 4140 or SAE 1045

G

NAAMS CODE	DIM "V" +1.5/-0.0	MAX OAL (REF)	Weight kg*	Dim. "A"	Dim. "B"	Dim. "C"	Dim. "D"	Dim. "E"	Dim. "F"	Dim. "G"	Dim. "H"	Dim. "I"	Dim. "J"	Dim. "K"	Dim. "L"	Dim. "M"
ACA150M	155.00	192.00	2.4	145.00	130.00	115.00	100.00	85.00								
ACA151M	185.00	222.00	2.6	175.00	160.00	145.00	130.00	115.00	100.00	85.00						
ACA152M	215.00	252.00	2.8	205.00	190.00	175.00	160.00	145.00	130.00	115.00	100.00	85.00				
ACA153M	245.00	282.00	3.0	235.00	220.00	205.00	190.00	175.00	160.00	145.00	130.00	115.00	100.00	85.00		
ACA154M	275.00	312.00	3.3	265.00	250.00	235.00	220.00	205.00	190.00	175.00	160.00	145.00	130.00	115.00	100.00	85.00
ACA155M	305.00	342.00	3.5	295.00	280.00	265.00	250.00	235.00	220.00	205.00	190.00	175.00	160.00	145.00	130.00	115.00
ACA156M	335.00	372.00	3.7	325.00	310.00	295.00	280.00	265.00	250.00	235.00	220.00	205.00	190.00	175.00	160.00	145.00
ACA157M	365.00	402.00	3.9	355.00	340.00	325.00	310.00	295.00	280.00	265.00	250.00	235.00	220.00	205.00	190.00	175.00
ACA158M	395.00	432.00	4.2	385.00	370.00	355.00	340.00	325.00	310.00	295.00	280.00	265.00	250.00	235.00	220.00	205.00

C

A

D

E

F

B

DOWEL

NAAMS CODE	Dim. "N"	Dim. "O"	Dim. "P"	Dim. "Q"	Dim. "R"	Dim. "S"	Dim. "T"	Dim. "U"
ACA155M	100.00	85.00						
ACA156M	130.00	115.00	100.00	85.00				
ACA157M	160.00	145.00	130.00	115.00	100.00	85.00		
ACA158M	190.00	175.00	160.00	145.00	130.00	115.00	100.00	85.00

DOWEL

\* Weight of arm as shown. Actual weight may vary due to variations in mounting details.

SEE DRAWING ON PREVIOUS PAGE

# POWER CLAMP ARMS 80/90 SERIES

(120mm OFFSET - MACHINED) (FULL METRIC)

GLOBAL STANDARD COMPONENTS



Assembly

11/10/10

E

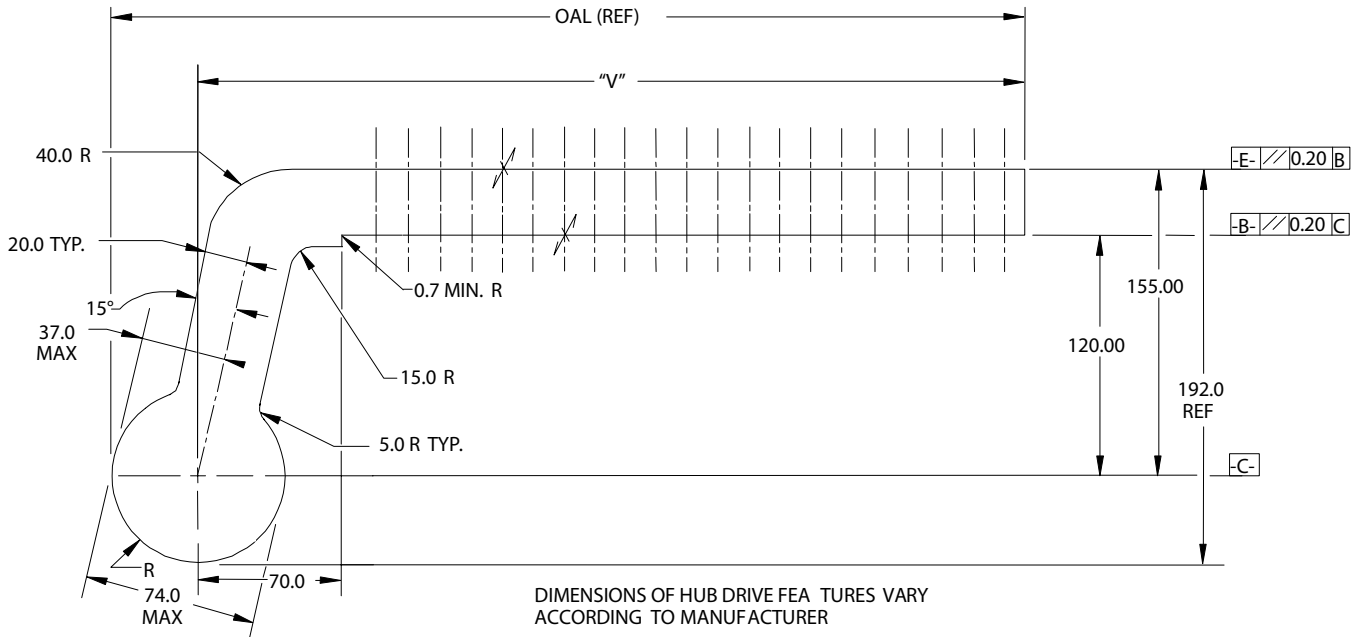

B

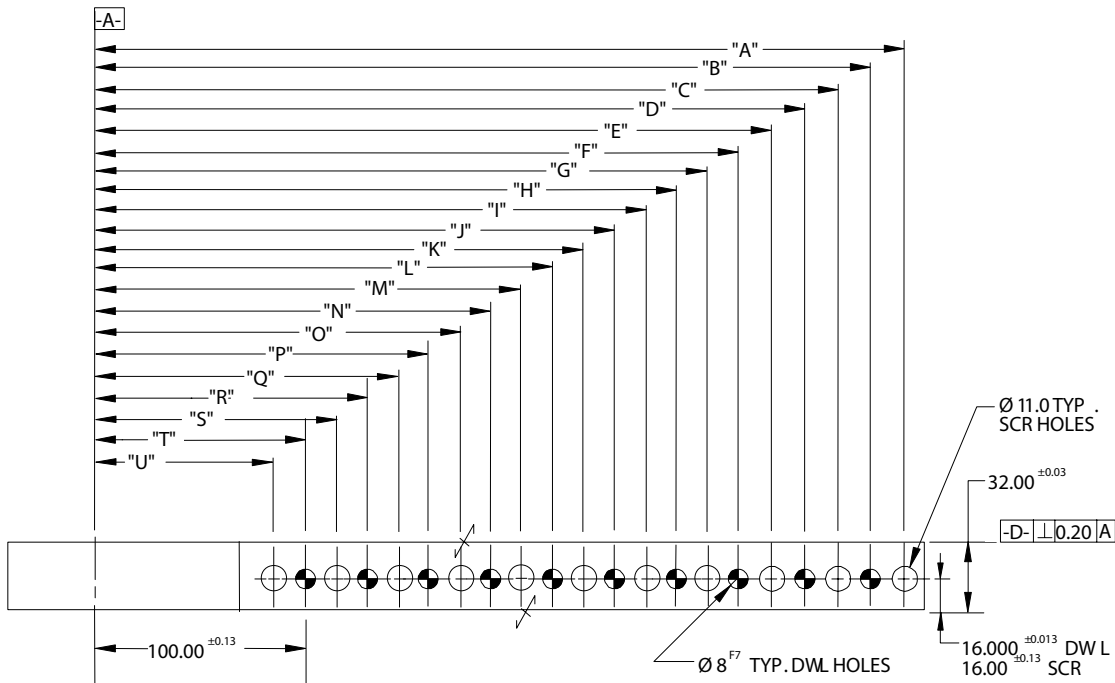

C

STAMP OR ETCH THE NAAMS CODE NUMBER AND THE CLAMP ARM MANUFACTURER'S NUMBER, IF DIFFERENT, ON THE SIDE OF THE ARM.

PAINT AS PRESCRIBED ON PAGE G-1.2

CLEARANCE HOLES G, I, K, M, O, Q, S AND U ARE OPTIONAL UNTIL FEBRUARY 1, 2006 AND MANDATORY THEREAFTER.

TABULATED INFORMATION ON FOLLOWING PAGE

D

A

# POWER CLAMP ARMS 80/90 SERIES

(120mm OFFSET - MACHINED) (FULL METRIC)

GLOBAL STANDARD COMPONENTS



Assembly

11/10/10

H

MAXIMUM ALLOWABLE ROUGHNESS SHALL BE:  
 1 PLACE FINISH DIMENSIONS TO BE 6 MICRONS  
 2 PLACE FINISH DIMENSIONS TO BE 3 MICRONS  
 3 PLACE FINISH DIMENSIONS TO BE 1.6 MICRONS

EXCEPT AS NOTED TOLERANCES SHALL BE:

- 1 PLACE MACHINING  $\pm 0.3$
- 1 PLACE FABRICATION  $\pm 1.5$
- 2 PLACE  $\pm 0.03$  GENERAL  
 $\pm 0.03$  BETWEEN DOWELS  
 $\pm 0.13$  TO SCREW HOLES

NOTES: ALL DIMENSIONS METRIC UNLESS OTHERWISE NOTED.

MATERIAL: SAE 4140 or SAE 1045

G

NAAMS CODE	DIM "V" +1.5/-0.0	MAX OAL (REF)	Weight kg*	Dim. "A"	Dim. "B"	Dim. "C"	Dim. "D"	Dim. "E"	Dim. "F"	Dim. "G"	Dim. "H"	Dim. "I"	Dim. "J"	Dim. "K"	Dim. "L"	Dim. "M"
ACA170M	155.00	192.00	2.8	145.00	130.00	115.00	100.00	85.00								
ACA171M	185.00	222.00	3.0	175.00	160.00	145.00	130.00	115.00	100.00	85.00						
ACA172M	215.00	252.00	3.2	205.00	190.00	175.00	160.00	145.00	130.00	115.00	100.00	85.00				
ACA173M	245.00	282.00	3.4	235.00	220.00	205.00	190.00	175.00	160.00	145.00	130.00	115.00	100.00	85.00		
ACA174M	275.00	312.00	3.7	265.00	250.00	235.00	220.00	205.00	190.00	175.00	160.00	145.00	130.00	115.00	100.00	85.00
ACA175M	305.00	342.00	3.9	295.00	280.00	265.00	250.00	235.00	220.00	205.00	190.00	175.00	160.00	145.00	130.00	115.00
ACA176M	335.00	372.00	4.1	325.00	310.00	295.00	280.00	265.00	250.00	235.00	220.00	205.00	190.00	175.00	160.00	145.00
ACA177M	365.00	402.00	4.3	355.00	340.00	325.00	310.00	295.00	280.00	265.00	250.00	235.00	220.00	205.00	190.00	175.00
ACA178M	395.00	432.00	4.6	385.00	370.00	355.00	340.00	325.00	310.00	295.00	280.00	265.00	250.00	235.00	220.00	205.00

C

A

D

E

F

B

DOWEL

NAAMS CODE	Dim. "N"	Dim. "O"	Dim. "P"	Dim. "Q"	Dim. "R"	Dim. "S"	Dim. "T"	Dim. "U"
ACA175M	100.00	85.00						
ACA176M	130.00	115.00	100.00	85.00				
ACA177M	160.00	145.00	130.00	115.00	100.00	85.00		
ACA178M	190.00	175.00	160.00	145.00	130.00	115.00	100.00	85.00

DOWEL

\* Weight of arm as shown. Actual weight may vary due to variations in mounting details.

SEE DRAWING ON PREVIOUS PAGE

# POWER CLAMP ARMS BLANKS 60 SERIES

(STRAIGHT) (INCH AND METRIC DESIGNS)

GLOBAL STANDARD COMPONENTS



Assembly

11/10/10

E  
A

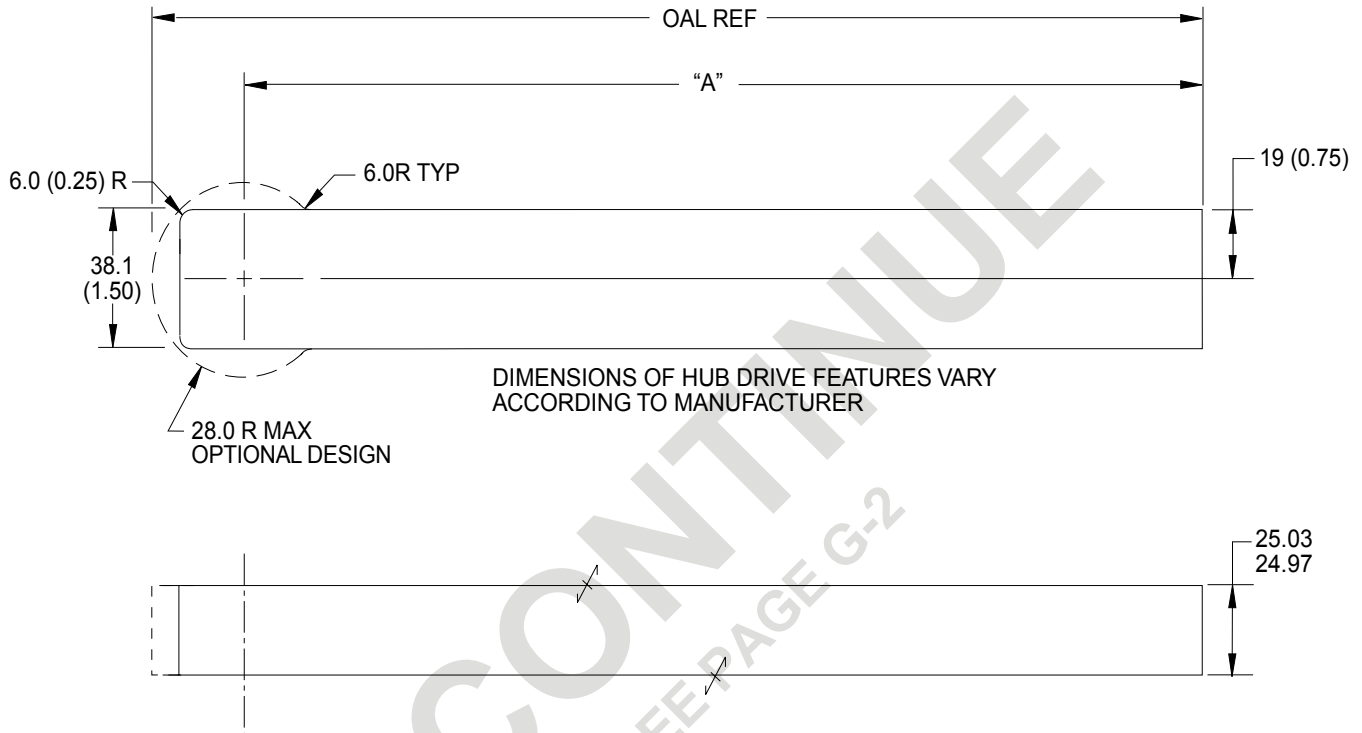

B

STAMP OR ETCH THE NAAMS CODE NUMBER AND THE CLAMP ARM MANUFACTURER'S NUMBER, IF DIFFERENT, ON THE SIDE OF THE ARM.

EXCEPT AS NOTED METRIC TOLERANCES SHALL BE:

- 1 PLACE MACHINING  $\pm 0.3$
- 1 PLACE FABRICATION  $\pm 1.5$

MATERIAL: SAE 4140 or SAE 1045

NOTES: ALL DIMENSIONS METRIC UNLESS OTHERWISE NOTED.  
DIMENSIONS IN PARENTHESES ARE INCH EQUIVALENT.

D

NAAMS CODE	DIM. "A"	MAX OAL (REF)	WEIGHT kg (lb)
ACA001	135.0 (5.31)	163.0 (6.42)	1.2 (2.6)
ACA002	165.0 (6.50)	193.0 (7.60)	1.4 (3.1)
ACA003	195.0 (7.68)	223.0 (8.78)	1.6 (3.5)
ACA004	225.0 (8.86)	253.0 (9.96)	1.9 (4.2)
ACA005	255.0 (10.04)	283.0 (11.14)	2.1 (4.6)
ACA006	285.0 (11.22)	313.0 (12.32)	2.3 (5.1)

C

# POWER CLAMP ARMS BLANKS 60 SERIES

GLOBAL STANDARD COMPONENTS



(20mm OFFSET) (INCH AND METRIC DESIGNS)

Assembly

11/10/10

E

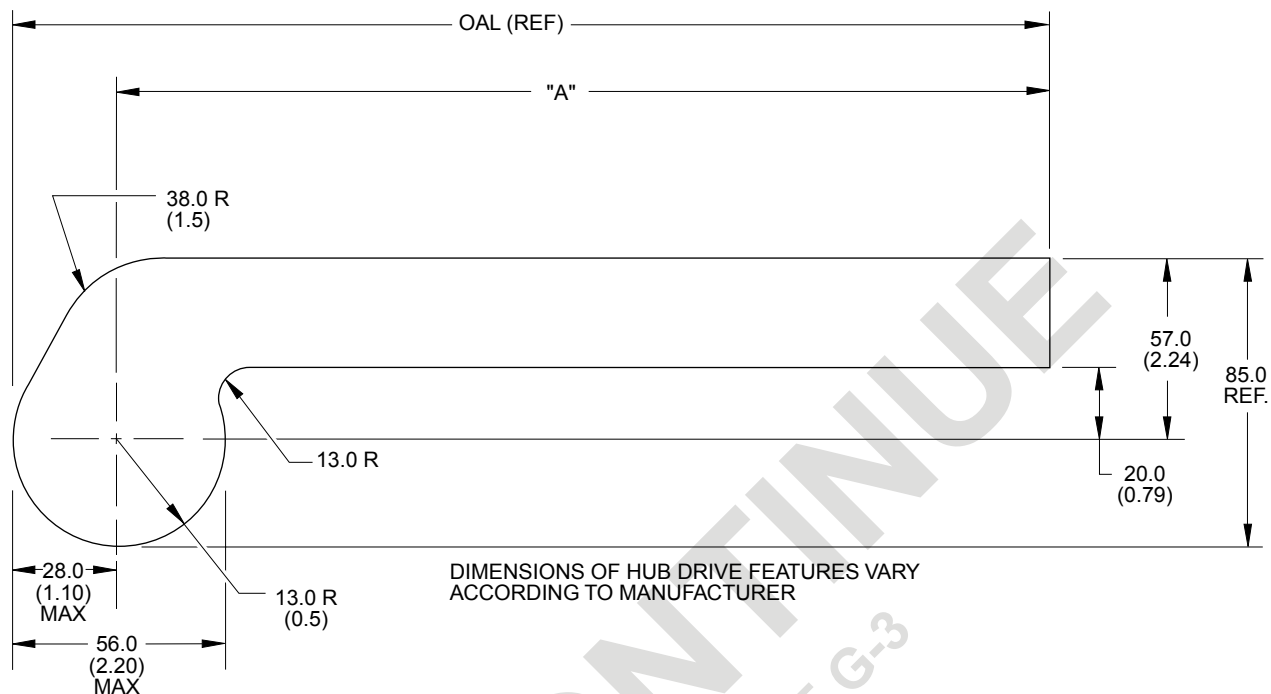

A

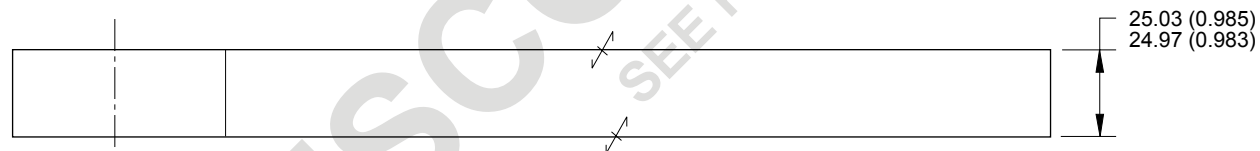

C

STAMP OR ETCH THE NAAMS CODE NUMBER AND THE CLAMP ARM MANUFACTURER'S NUMBER, IF DIFFERENT, ON THE SIDE OF THE ARM.

EXCEPT AS NOTED METRIC TOLERANCES SHALL BE:

- 1 PLACE MACHINING  $\pm 0.3$
- 1 PLACE FABRICATION  $\pm 1.5$

MATERIAL: SAE 4140 or SAE 1045

NOTES: ALL DIMENSIONS METRIC UNLESS OTHERWISE NOTED.  
DIMENSIONS IN PARENTHESES ARE INCH EQUIVALENT.

D

NAAMS CODE	DIM. "A"	MAX OAL (REF)	WEIGHT kg (lb)
ACA013	135.0 (5.31)	163.0 (6.42)	1.3 (2.9)
ACA014	165.0 (6.50)	193.0 (7.60)	1.6 (3.5)
ACA015	195.0 (7.68)	223.0 (8.78)	1.8 (4.0)
ACA016	225.0 (8.86)	253.0 (9.96)	2.0 (4.4)
ACA017	255.0 (10.04)	283.0 (11.14)	2.2 (4.9)
ACA018	285.0 (11.22)	313.0 (12.32)	2.4 (5.3)

B

# POWER CLAMP ARMS BLANKS 60 SERIES

(60mm OFFSET) (INCH AND METRIC DESIGNS)

GLOBAL STANDARD COMPONENTS



Assembly

11/10/10

F

A

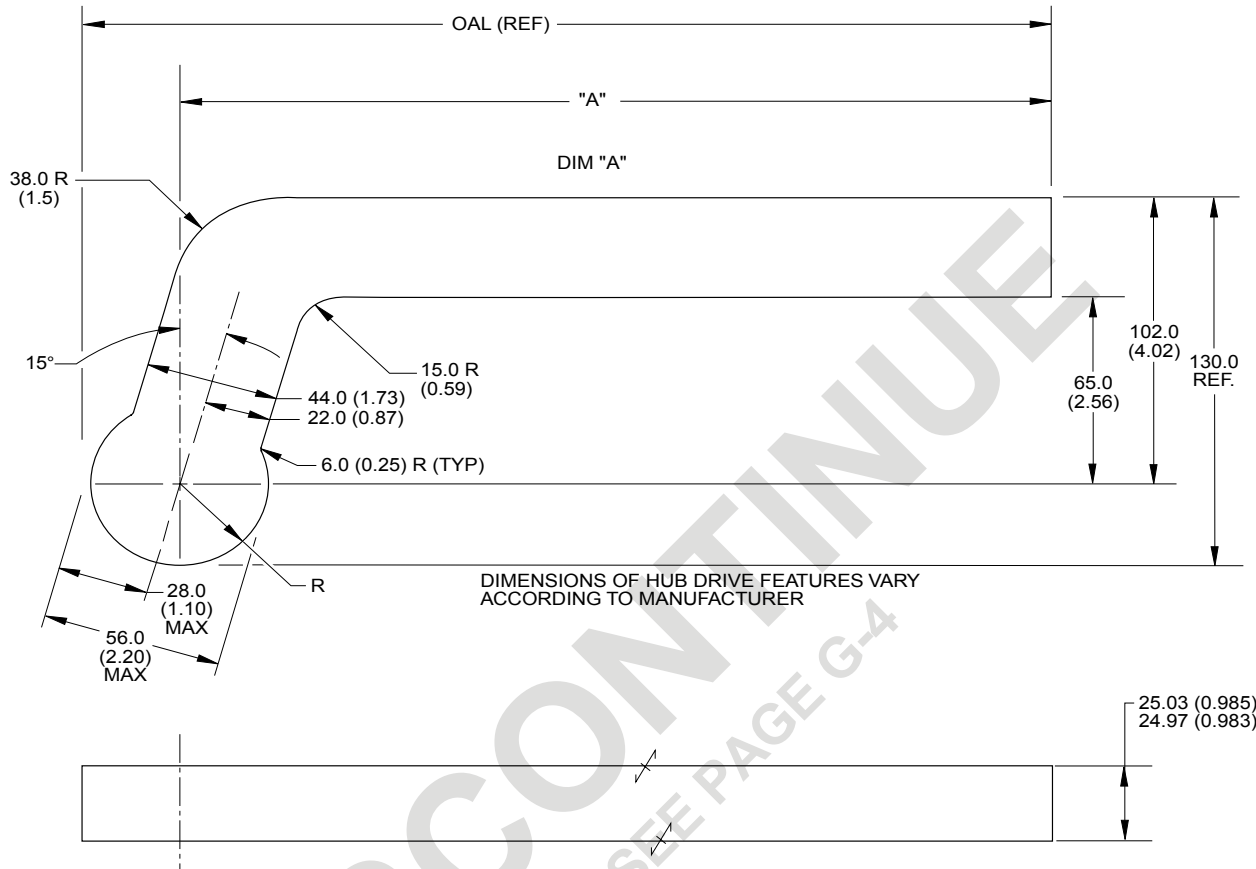

B

D

STAMP OR ETCH THE NAAMS CODE NUMBER AND THE CLAMP ARM MANUFACTURER'S NUMBER, IF DIFFERENT, ON THE SIDE OF THE ARM.

EXCEPT AS NOTED METRIC TOLERANCES SHALL BE:

- 1 PLACE MACHINING  $\pm 0.3$
- 1 PLACE FABRICATION  $\pm 1.5$

MATERIAL: SAE 4140 or SAE 1045

NOTES: ALL DIMENSIONS METRIC UNLESS OTHERWISE NOTED.  
DIMENSIONS IN PARENTHESES ARE INCH EQUIVALENT.

E

NAAMS CODE	DIM. "A"	MAX OAL (REF)	WEIGHT kg (lb)
ACA025	135.0 (5.31)	163.0 (6.42)	1.7 (3.7)
ACA026	165.0 (6.50)	193.0 (7.60)	1.9 (4.2)
ACA027	195.0 (7.68)	223.0 (8.78)	2.1 (4.6)
ACA028	225.0 (8.86)	253.0 (9.96)	2.4 (5.3)
ACA029	255.0 (10.04)	283.0 (11.14)	2.6 (5.7)
ACA030	285.0 (11.22)	313.0 (12.32)	2.8 (6.2)

C



# POWER CLAMP ARMS BLANKS 60 SERIES

GLOBAL STANDARD COMPONENTS



(115mm OFFSET) (INCH AND METRIC DESIGNS)

Assembly

11/10/10

F  
A

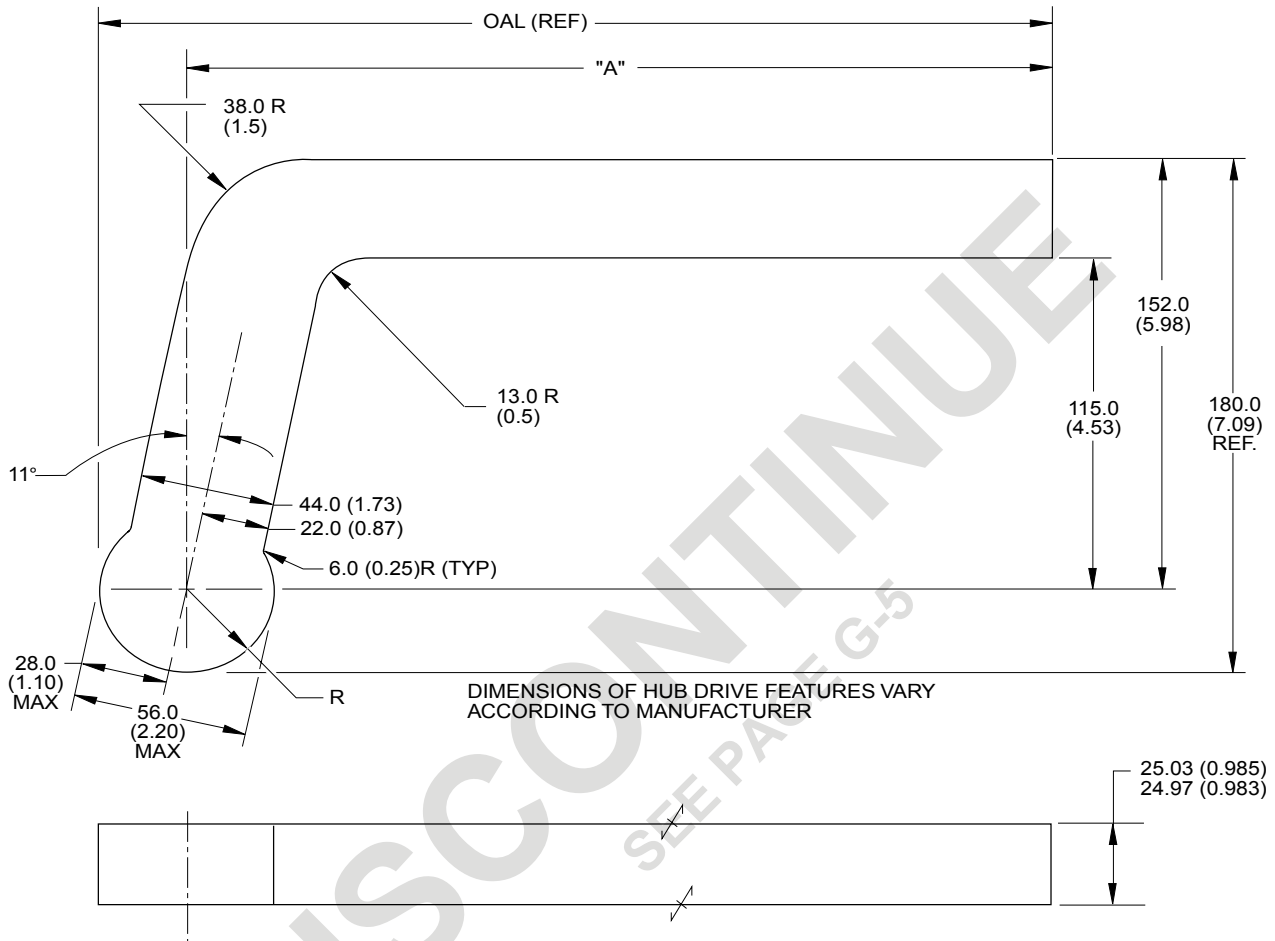

B

D

STAMP OR ETCH THE NAAMS CODE NUMBER AND THE CLAMP ARM MANUFACTURER'S NUMBER, IF DIFFERENT, ON THE SIDE OF THE ARM.

EXCEPT AS NOTED METRIC TOLERANCES SHALL BE:

- 1 PLACE MACHINING  $\pm 0.3$
- 1 PLACE FABRICATION  $\pm 1.5$

MATERIAL: SAE 4140 or SAE 1045

NOTES: ALL DIMENSIONS METRIC UNLESS OTHERWISE NOTED.  
DIMENSIONS IN PARENTHESES ARE INCH EQUIVALENT.

E

NAAMS CODE	DIM. "A"	MAX OAL (REF)	WEIGHT kg (lb)
ACA037	135.0 (5.31)	163.0 (6.42)	2.1 (4.6)
ACA038	165.0 (6.50)	193.0 (7.60)	2.3 (5.1)
ACA039	195.0 (7.68)	223.0 (8.78)	2.5 (5.5)
ACA040	225.0 (8.86)	253.0 (9.96)	2.7 (6.0)
ACA041	255.0 (10.04)	283.0 (11.14)	2.9 (6.4)
ACA042	285.0 (11.22)	313.0 (12.32)	3.2 (7.1)

C

# POWER CLAMP ARMS 60 SERIES (STRAIGHT - MACHINED)

I  
B

H  
A

D

F

E

D

G

C

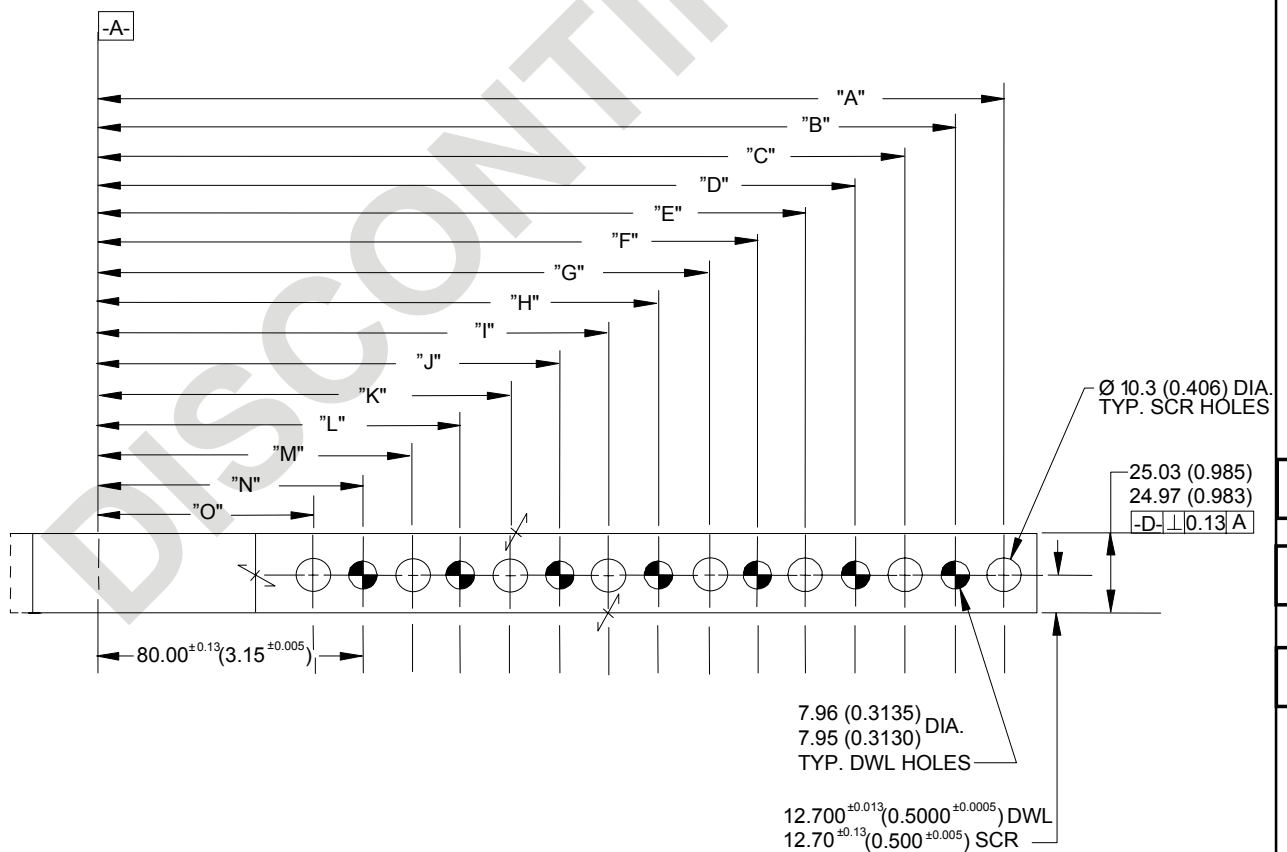
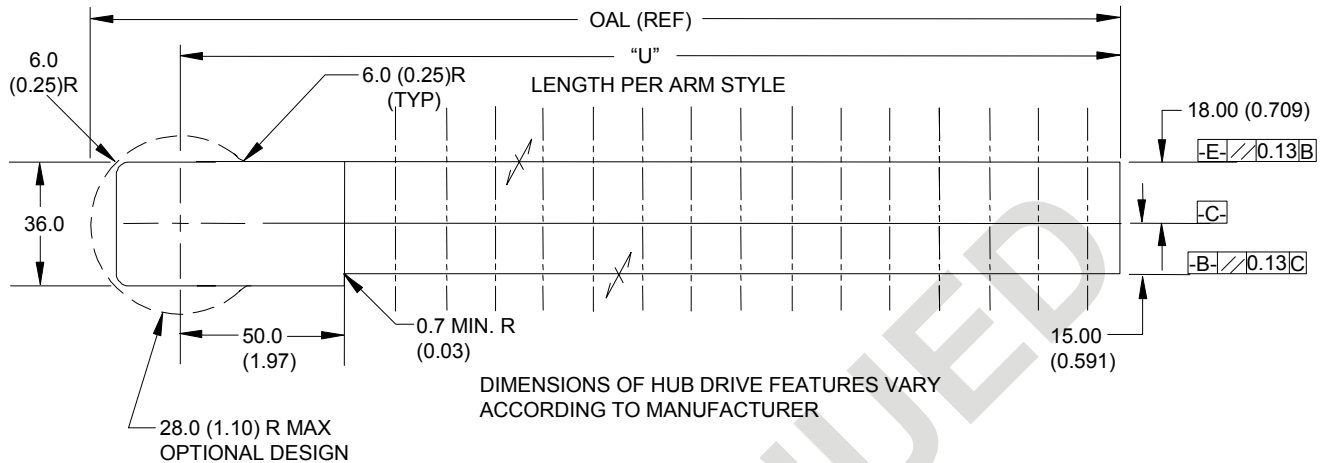

STAMP OR ETCH THE NAAMS CODE NUMBER AND THE CLAMP ARM MANUFACTURER'S NUMBER, IF DIFFERENT, ON THE SIDE OF THE ARM.

PAINT AS PRESCRIBED ON PAGE G-1.2

CLEARANCE HOLES G, I, K, M AND O ARE OPTIONAL UNTIL FEBRUARY 1, 2006 AND MANDATORY THEREAFTER.

TABULATED INFORMATION ON FOLLOWING PAGE

# POWER CLAMP ARMS 60 SERIES (STRAIGHT - MACHINED)

E

EXCEPT AS NOTED METRIC TOLERANCES SHALL BE:

- 1 PLACE MACHINING  $\pm 0.3$
- 1 PLACE FABRICATION  $\pm 1.5$
- 2 PLACE  $\pm 0.03$  GENERAL
  - $\pm 0.03$  BETWEEN DOWELS
  - $\pm 0.13$  TO SCREW HOLES

NOTES: ALL DIMENSIONS METRIC UNLESS OTHERWISE NOTED.  
DIMENSIONS IN PARENTHESES ARE INCH EQUIVALENT.

MATERIAL: 4140 OR EQUIVALENT

NAAMS CODE	DIM "U" +1.5/-0.0	MAX OAL (REF)	Weight kg*	Dim. "A"	Dim. "B"	Dim. "C"	Dim. "D"	Dim. "E"	Dim. "F"	Dim. "G"	Dim. "H"	Dim. "I"	Dim. "J"	Dim. "K"	Dim. "L"	Dim. "M"
ACA007	135.0 (5.31)	163.0 (6.42)	1.0 (2.2)	125.00 (4.921)	110.00 (4.331)	95.00 (3.740)	80.00 (3.150)	65.00 (2.559)								
ACA008	165.0 (6.50)	193.0 (7.60)	1.2 (2.6)	155.00 (6.102)	140.00 (5.512)	125.00 (4.921)	110.00 (4.331)	95.00 (3.740)	80.00 (3.150)	65.00 (2.559)						
ACA009	195.0 (7.68)	223.0 (8.78)	1.3 (2.9)	185.00 (7.283)	170.00 (6.693)	155.00 (6.102)	140.00 (5.512)	125.00 (4.921)	110.00 (4.331)	95.00 (3.740)	80.00 (3.150)	65.00 (2.559)				
ACA010	225.0 (8.86)	253.0 (9.96)	1.4 (3.1)	215.00 (8.464)	200.00 (7.874)	185.00 (7.283)	170.00 (6.693)	155.00 (6.102)	140.00 (5.512)	125.00 (4.921)	110.00 (4.331)	95.00 (3.740)	80.00 (3.150)	65.00 (2.559)		
ACA011	255.0 (10.04)	283.0 (11.14)	1.6 (3.5)	245.00 (9.646)	230.00 (9.055)	215.00 (8.464)	200.00 (7.874)	185.00 (7.283)	170.00 (6.693)	155.00 (6.102)	140.00 (5.512)	125.00 (4.921)	110.00 (4.331)	95.00 (3.740)	80.00 (3.150)	65.00 (2.559)
ACA012	285.0 (11.22)	313.0 (12.32)	1.8 (4.0)	275.00 (10.827)	260.00 (10.236)	245.00 (9.646)	230.00 (9.055)	215.00 (8.464)	200.00 (7.874)	185.00 (7.283)	170.00 (6.693)	155.00 (6.102)	140.00 (5.512)	125.00 (4.921)	110.00 (4.331)	95.00 (3.740)

A

B

C

DOWEL

D

NAAMS CODE	Dim. "N"	Dim. "O"
ACA012	80.00 (3.150)	65.00 (2.559)

DOWEL

\* Weight of arm as shown. Actual weight may vary due to variations in mounting details.

SEE DRAWING ON PREVIOUS PAGE

# POWER CLAMP ARMS 60 SERIES

(25mm OFFSET - MACHINED)

G

F

B

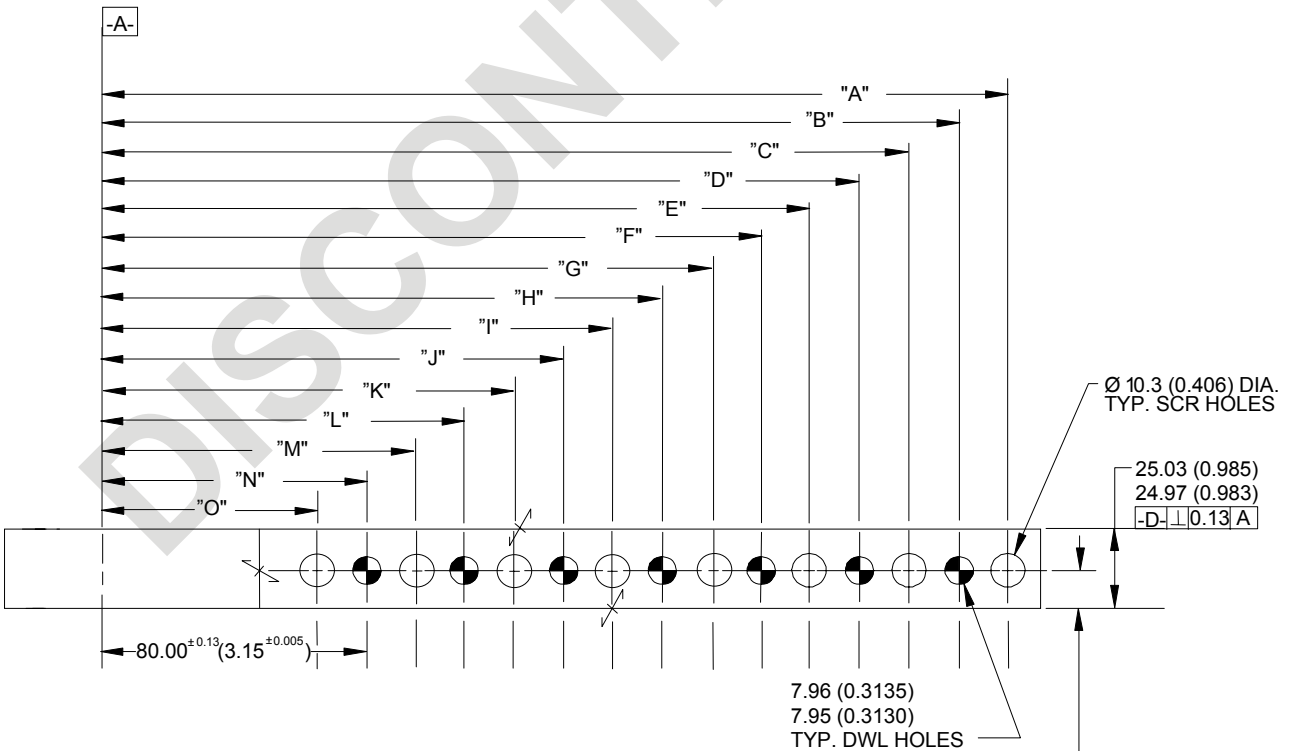
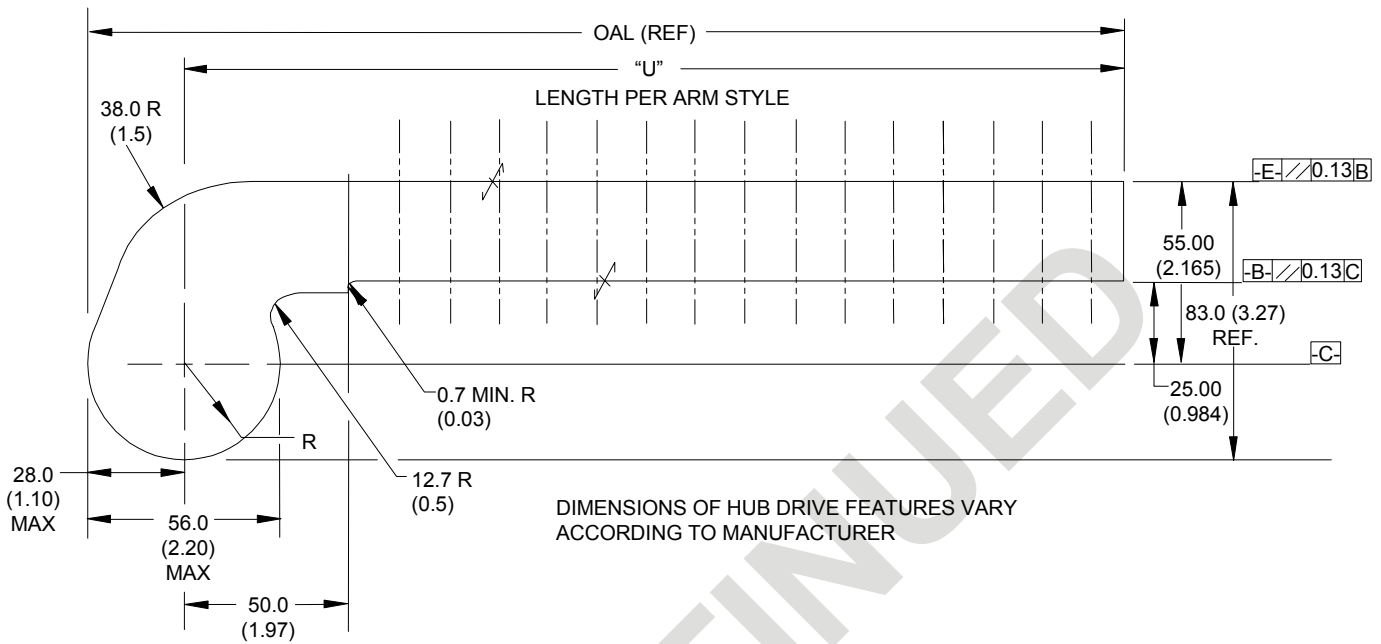

D

C

E

A

STAMP OR ETCH THE NAAMS CODE NUMBER AND THE CLAMP ARM MANUFACTURER'S NUMBER, IF DIFFERENT, ON THE SIDE OF THE ARM.

PAINT AS PRESCRIBED ON PAGE G-1.2

CLEARANCE HOLES G, I, K, M AND O ARE OPTIONAL UNTIL FEBRUARY 1, 2006 AND MANDATORY THEREAFTER.

TABULATED INFORMATION ON FOLLOWING PAGE

# POWER CLAMP ARMS 60 SERIES (25mm OFFSET - MACHINED)

E

EXCEPT AS NOTED METRIC TOLERANCES SHALL BE:

- 1 PLACE MACHINING  $\pm 0.3$
- 1 PLACE FABRICATION  $\pm 1.5$
- 2 PLACE  $\pm 0.03$  GENERAL
  - $\pm 0.03$  BETWEEN DOWELS
  - $\pm 0.13$  TO SCREW HOLES

NOTES: ALL DIMENSIONS METRIC UNLESS OTHERWISE NOTED.  
DIMENSIONS IN PARENTHESES ARE INCH EQUIVALENT.

MATERIAL: 4140 OR EQUIVALENT

NAAMS CODE	DIM "U" +1.5/-0.0	MAX OAL (REF)	Weight kg*	Dim. "A"	Dim. "B"	Dim. "C"	Dim. "D"	Dim. "E"	Dim. "F"	Dim. "G"	Dim. "H"	Dim. "I"	Dim. "J"	Dim. "K"	Dim. "L"	Dim. "M"
ACA019	135.0 (5.31)	163.0 (6.42)	1.1 (2.4)	125.00 (4.921)	110.00 (4.331)	95.00 (3.740)	80.00 (3.150)	65.00 (2.559)								
ACA020	165.0 (6.50)	193.0 (7.60)	1.3 (2.9)	155.00 (6.102)	140.00 (5.512)	125.00 (4.921)	110.00 (4.331)	95.00 (3.740)	80.00 (3.150)	65.00 (2.559)						
ACA021	195.0 (7.68)	223.0 (8.78)	1.4 (3.1)	185.00 (7.283)	170.00 (6.693)	155.00 (6.102)	140.00 (5.512)	125.00 (4.921)	110.00 (4.331)	95.00 (3.740)	80.00 (3.150)	65.00 (2.559)				
ACA022	225.0 (8.86)	253.0 (9.96)	1.5 (3.3)	215.00 (8.464)	200.00 (7.874)	185.00 (7.283)	170.00 (6.693)	155.00 (6.102)	140.00 (5.512)	125.00 (4.921)	110.00 (4.331)	95.00 (3.740)	80.00 (3.150)	65.00 (2.559)		
ACA023	255.0 (10.04)	283.0 (11.14)	1.6 (3.5)	245.00 (9.646)	230.00 (9.055)	215.00 (8.464)	200.00 (7.874)	185.00 (7.283)	170.00 (6.693)	155.00 (6.102)	140.00 (5.512)	125.00 (4.921)	110.00 (4.331)	95.00 (3.740)	80.00 (3.150)	65.00 (2.559)
ACA024	285.0 (11.22)	313.0 (12.32)	1.9 (4.2)	275.00 (10.827)	260.00 (10.236)	245.00 (9.646)	230.00 (9.055)	215.00 (8.464)	200.00 (7.874)	185.00 (7.283)	170.00 (6.693)	155.00 (6.102)	140.00 (5.512)	125.00 (4.921)	110.00 (4.331)	95.00 (3.740)

A

B

C

DOWEL

D

NAAMS CODE	Dim. "N"	Dim. "O"
ACA024	80.00 (3.150)	65.00 (2.559)

DOWEL

\* Weight of arm as shown. Actual weight may vary due to variations in mounting details.

SEE DRAWING ON PREVIOUS PAGE

# POWER CLAMP ARMS 60 SERIES (70mm OFFSET - MACHINED)

H  
A

G

C

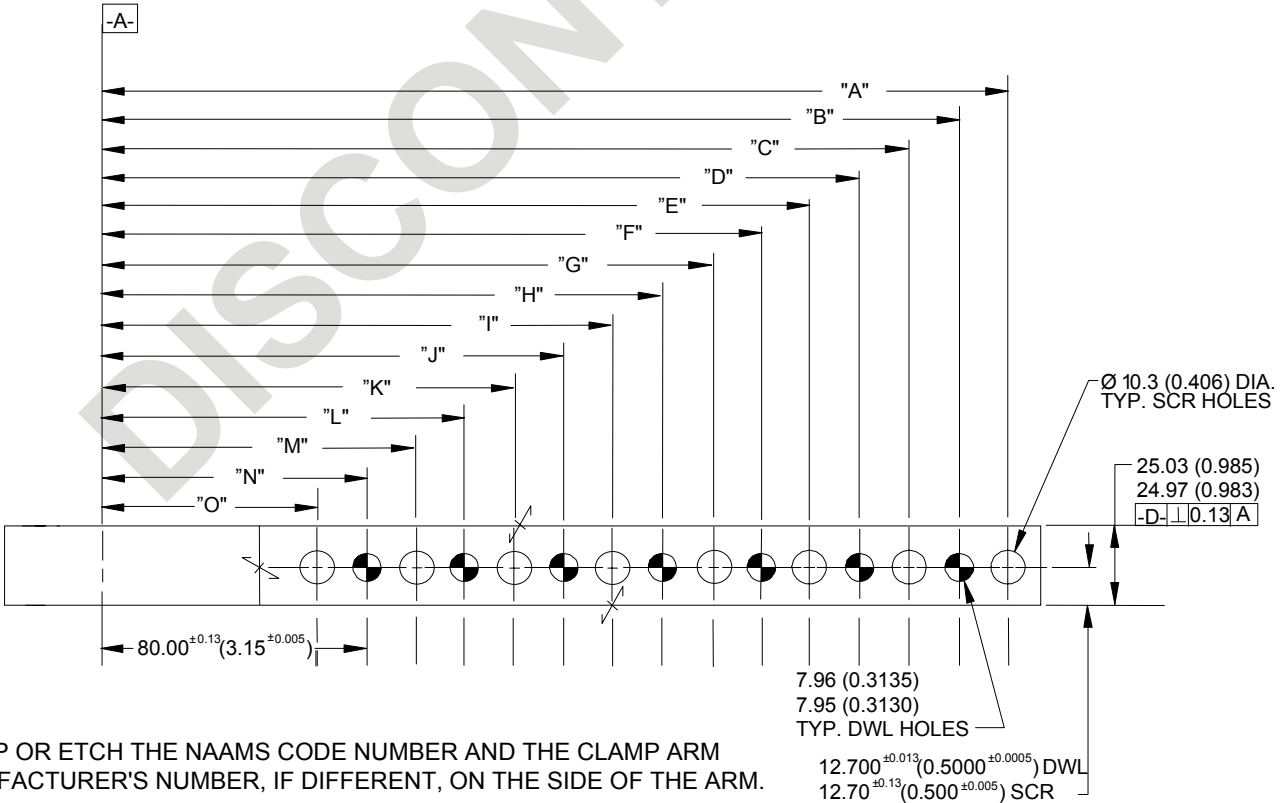
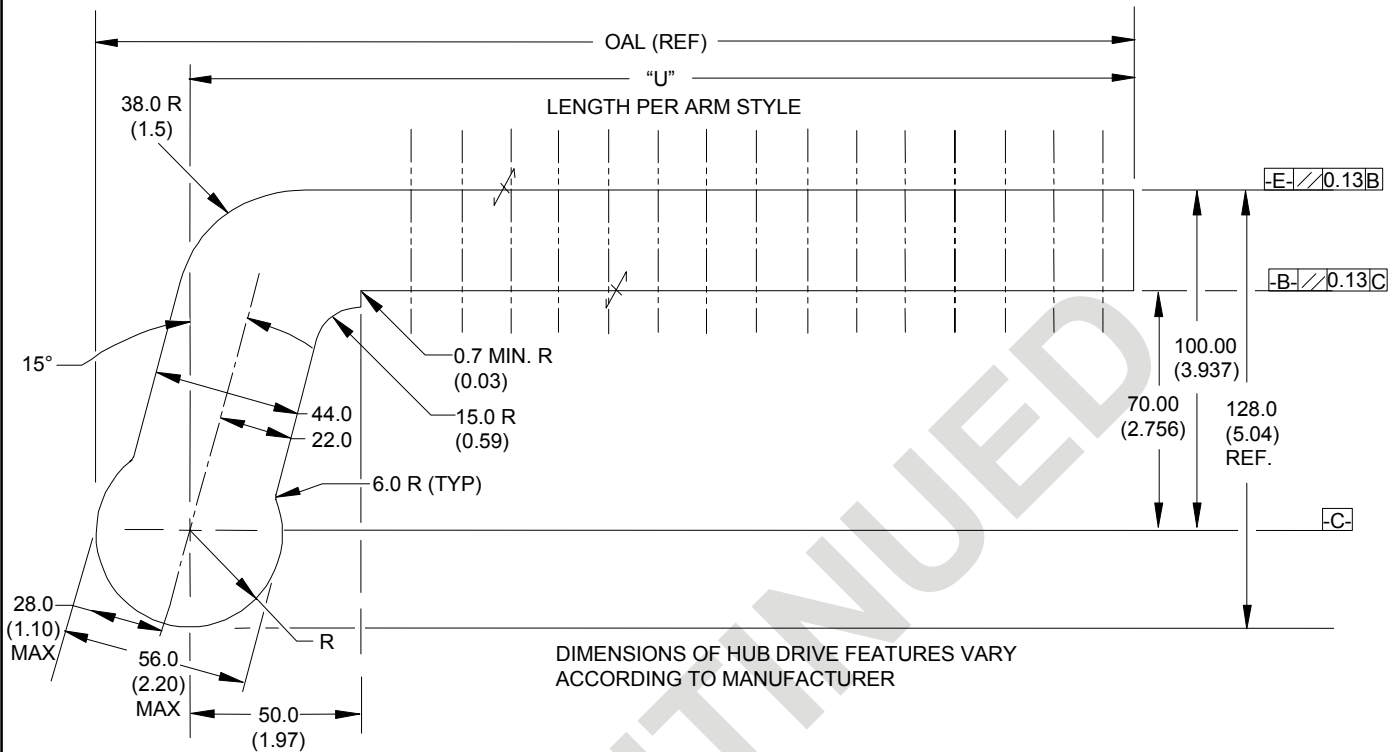

E

D

F

B

STAMP OR ETCH THE NAAMS CODE NUMBER AND THE CLAMP ARM MANUFACTURER'S NUMBER, IF DIFFERENT, ON THE SIDE OF THE ARM.

PAINT AS PRESCRIBED ON PAGE G-1.2

CLEARANCE HOLES G, I, K, M AND O ARE OPTIONAL UNTIL FEBRUARY 1, 2006 AND MANDATORY THEREAFTER.

TABULATED INFORMATION ON FOLLOWING PAGE

# POWER CLAMP ARMS 60 SERIES (70mm OFFSET - MACHINED)

EXCEPT AS NOTED METRIC TOLERANCES SHALL BE:

- 1 PLACE MACHINING  $\pm 0.3$
- 1 PLACE FABRICATION  $\pm 1.5$
- 2 PLACE  $\pm 0.03$  GENERAL
- $\pm 0.03$  BETWEEN DOWELS
- $\pm 0.13$  TO SCREW HOLES

NOTES: ALL DIMENSIONS METRIC UNLESS OTHERWISE NOTED.  
DIMENSIONS IN PARENTHESES ARE INCH EQUIVALENT.

MATERIAL: 4140 OR EQUIVALENT

NAAMS CODE	DIM "U" +1.5/-0.0	MAX OAL (REF)	Weight kg*	Dim. "A"	Dim. "B"	Dim. "C"	Dim. "D"	Dim. "E"	Dim. "F"	Dim. "G"	Dim. "H"	Dim. "I"	Dim. "J"	Dim. "K"	Dim. "L"	Dim. "M"
ACA031	135.0 (5.31)	163.0 (6.42)	1.5 (3.3)	125.00 (4.921)	110.00 (4.331)	95.00 (3.740)	80.00 (3.150)	65.00 (2.559)								
ACA032	165.0 (6.50)	193.0 (7.60)	1.7 (3.7)	155.00 (6.102)	140.00 (5.512)	125.00 (4.921)	110.00 (4.331)	95.00 (3.740)	80.00 (3.150)	65.00 (2.559)						
ACA033	195.0 (7.68)	223.0 (8.78)	1.8 (4.0)	185.00 (7.283)	170.00 (6.693)	155.00 (6.102)	140.00 (5.512)	125.00 (4.921)	110.00 (4.331)	95.00 (3.740)	80.00 (3.150)	65.00 (2.559)				
ACA034	225.0 (8.86)	253.0 (9.96)	1.9 (4.2)	215.00 (8.464)	200.00 (7.874)	185.00 (7.283)	170.00 (6.693)	155.00 (6.102)	140.00 (5.512)	125.00 (4.921)	110.00 (4.331)	95.00 (3.740)	80.00 (3.150)	65.00 (2.559)		
ACA035	255.0 (10.04)	283.0 (11.14)	2.0 (4.4)	245.00 (9.646)	230.00 (9.055)	215.00 (8.464)	200.00 (7.874)	185.00 (7.283)	170.00 (6.693)	155.00 (6.102)	140.00 (5.512)	125.00 (4.921)	110.00 (4.331)	95.00 (3.740)	80.00 (3.150)	65.00 (2.559)
ACA036	285.0 (11.22)	313.0 (12.32)	2.2 (4.9)	275.00 (10.827)	260.00 (10.236)	245.00 (9.646)	230.00 (9.055)	215.00 (8.464)	200.00 (7.874)	185.00 (7.283)	170.00 (6.693)	155.00 (6.102)	140.00 (5.512)	125.00 (4.921)	110.00 (4.331)	95.00 (3.740)

DOWEL

A

B

C

D

NAAMS CODE	Dim. "N"	Dim. "O"
ACA036	80.00 (3.150)	65.00 (2.559)

DOWEL

\* Weight of arm as shown. Actual weight may vary due to variations in mounting details.

SEE DRAWING ON PREVIOUS PAGE

# POWER CLAMP ARMS 60 SERIES (120mm OFFSET - MACHINED)

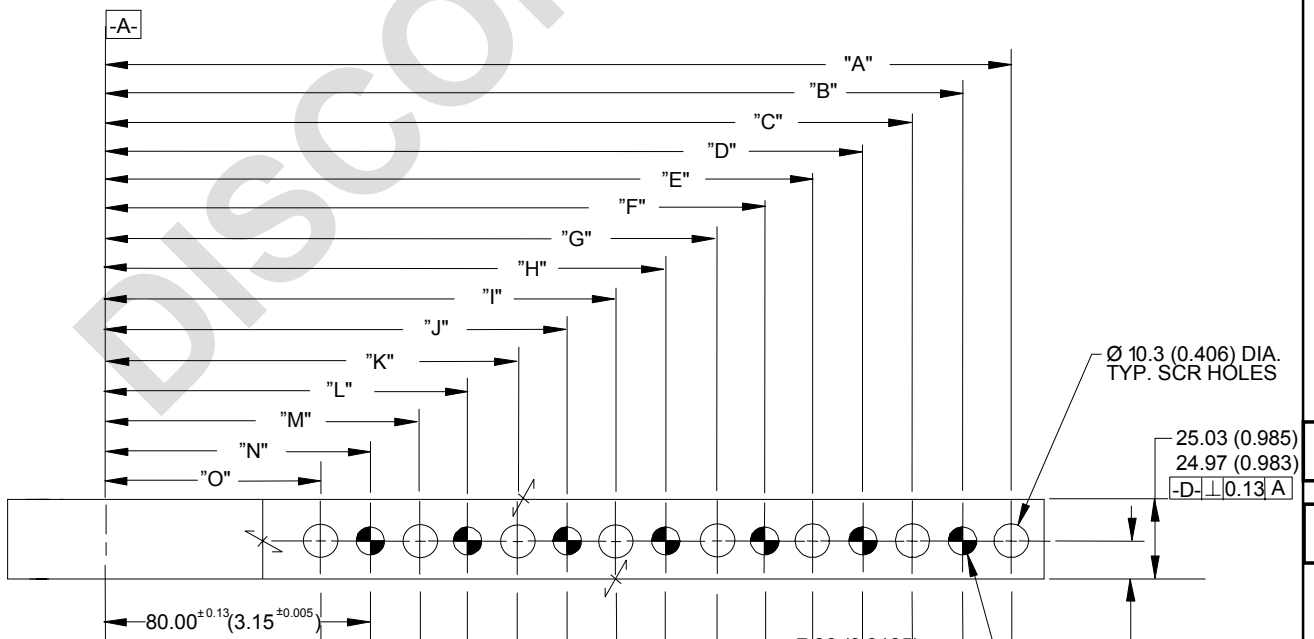
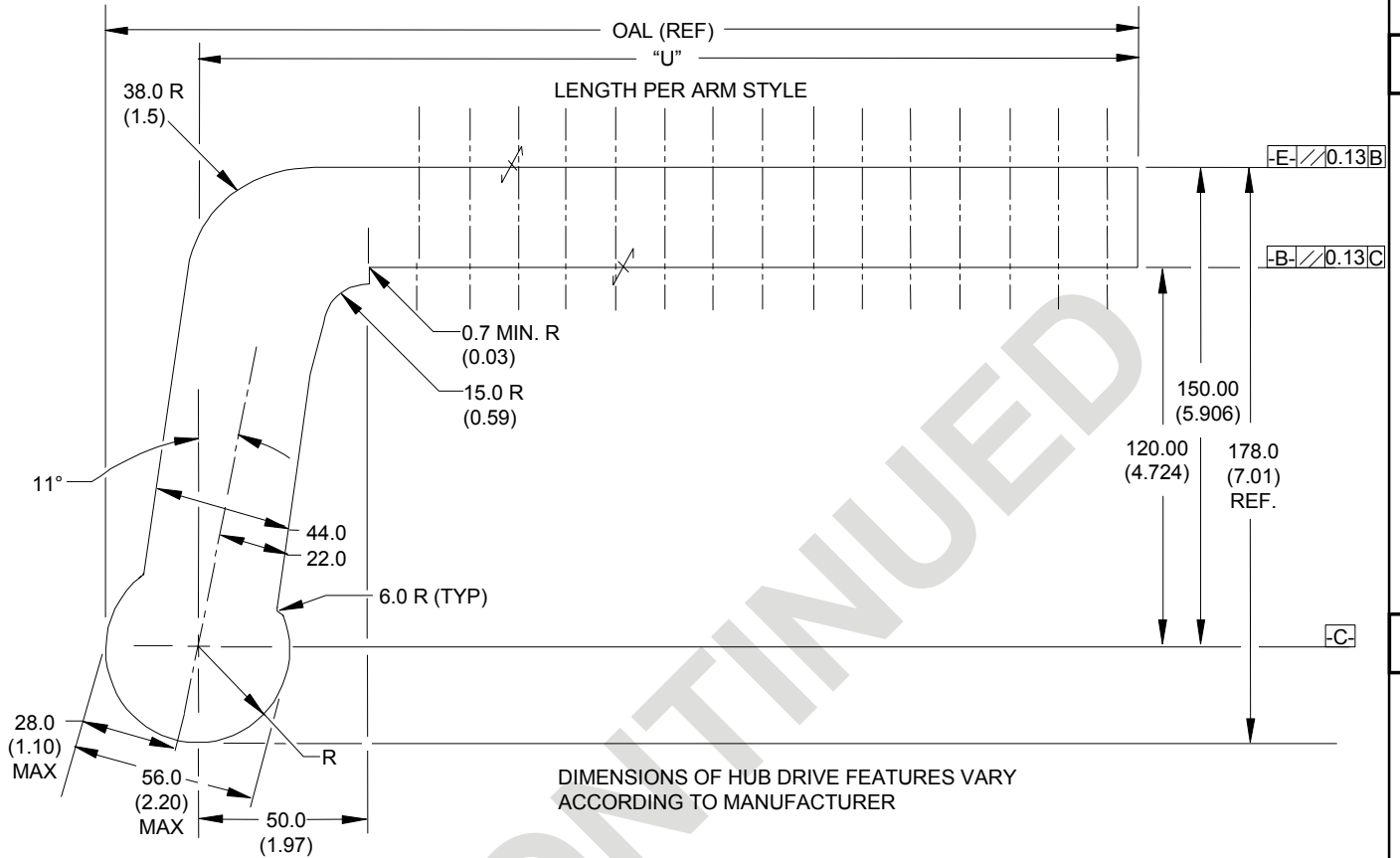

STAMP OR ETCH THE NAAMS CODE NUMBER AND THE CLAMP ARM MANUFACTURER'S NUMBER, IF DIFFERENT, ON THE SIDE OF THE ARM.

PAINT AS PRESCRIBED ON PAGE G-1.2

CLEARANCE HOLES G, I, K, M AND O ARE OPTIONAL UNTIL FEBRUARY 1, 2006 AND MANDATORY THEREAFTER.

TABULATED INFORMATION ON FOLLOWING PAGE



# POWER CLAMP ARMS 60 SERIES (120mm OFFSET - MACHINED)

E

EXCEPT AS NOTED METRIC TOLERANCES SHALL BE:

- 1 PLACE MACHINING  $\pm 0.3$
- 1 PLACE FABRICATION  $\pm 1.5$
- 2 PLACE  $\pm 0.03$  GENERAL
  - $\pm 0.03$  BETWEEN DOWELS
  - $\pm 0.13$  TO SCREW HOLES

NOTES: ALL DIMENSIONS METRIC UNLESS OTHERWISE NOTED.  
DIMENSIONS IN PARENTHESES ARE INCH EQUIVALENT.

MATERIAL: 4140 OR EQUIVALENT

NAAMS CODE	DIM "U" +1.5/-0.0	MAX OAL (REF)	Weight kg*	Dim. "A"	Dim. "B"	Dim. "C"	Dim. "D"	Dim. "E"	Dim. "F"	Dim. "G"	Dim. "H"	Dim. "I"	Dim. "J"	Dim. "K"	Dim. "L"	Dim. "M"
ACA043	135.0 (5.31)	163.0 (6.42)	1.9 (4.2)	125.00 (4.921)	110.00 (4.331)	95.00 (3.740)	80.00 (3.150)	65.00 (2.559)								
ACA044	165.0 (6.50)	193.0 (7.60)	2.0 (4.4)	155.00 (6.102)	140.00 (5.512)	125.00 (4.921)	110.00 (4.331)	95.00 (3.740)	80.00 (3.150)	65.00 (2.559)						
ACA045	195.0 (7.68)	223.0 (8.78)	2.1 (4.6)	185.00 (7.283)	170.00 (6.693)	155.00 (6.102)	140.00 (5.512)	125.00 (4.921)	110.00 (4.331)	95.00 (3.740)	80.00 (3.150)	65.00 (2.559)				
ACA046	225.0 (8.86)	253.0 (9.96)	2.2 (4.9)	215.00 (8.464)	200.00 (7.874)	185.00 (7.283)	170.00 (6.693)	155.00 (6.102)	140.00 (5.512)	125.00 (4.921)	110.00 (4.331)	95.00 (3.740)	80.00 (3.150)	65.00 (2.559)		
ACA047	255.0 (10.04)	283.0 (11.14)	2.4 (5.3)	245.00 (9.646)	230.00 (9.055)	215.00 (8.464)	200.00 (7.874)	185.00 (7.283)	170.00 (6.693)	155.00 (6.102)	140.00 (5.512)	125.00 (4.921)	110.00 (4.331)	95.00 (3.740)	80.00 (3.150)	65.00 (2.559)
ACA048	285.0 (11.22)	313.0 (12.32)	2.6 (5.7)	275.00 (10.827)	260.00 (10.236)	245.00 (9.646)	230.00 (9.055)	215.00 (8.464)	200.00 (7.874)	185.00 (7.283)	170.00 (6.693)	155.00 (6.102)	140.00 (5.512)	125.00 (4.921)	110.00 (4.331)	95.00 (3.740)

A  
B  
C

DOWEL

D

NAAMS CODE	Dim. "N"	Dim. "O"
ACA048	80.00 (3.150)	65.00 (2.559)

DOWEL

\* Weight of arm as shown. Actual weight may vary due to variations in mounting details.

SEE DRAWING ON PREVIOUS PAGE

# POWER CLAMP ARMS 80/90 SERIES (STRAIGHT - MACHINED)

E

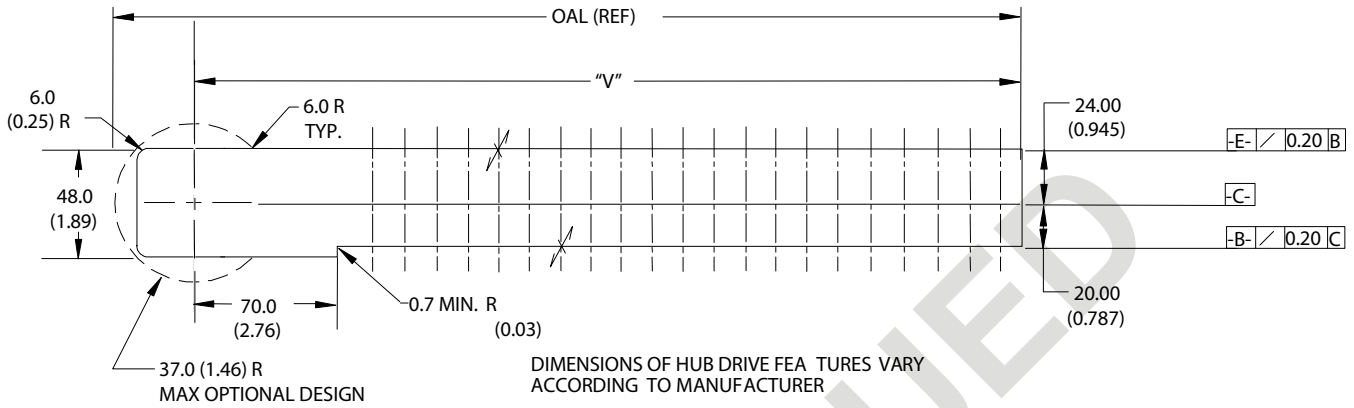

B

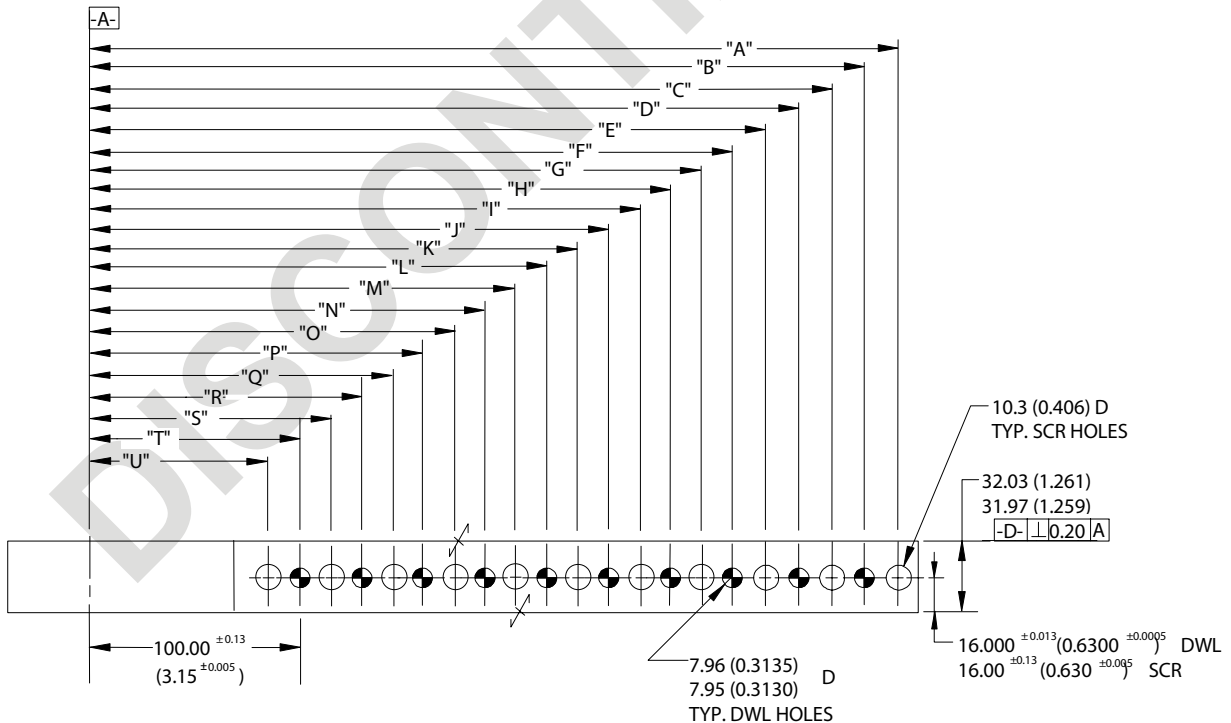

C

STAMP OR ETCH THE NAAMS CODE NUMBER AND THE CLAMP ARM MANUFACTURER'S NUMBER, IF DIFFERENT, ON THE SIDE OF THE ARM.

PAINT AS PRESCRIBED ON PAGE G-1.2

CLEARANCE HOLES G, I, K, M, O, Q, S AND U ARE OPTIONAL UNTIL FEBRUARY 1, 2006 AND MANDATORY THEREAFTER.

TABULATED INFORMATION ON FOLLOWING PAGE

D

A

# POWER CLAMP ARMS 80/90 SERIES (STRAIGHT - MACHINED)

G

MAXIMUM ALLOWABLE ROUGHNESS SHALL BE:  
1 PLACE FINISH DIMENSIONS TO BE 6 MICRONS  
2 PLACE FINISH DIMENSIONS TO BE 3 MICRONS  
3 PLACE FINISH DIMENSIONS TO BE 1.6 MICRONS

EXCEPT AS NOTED TOLERANCES SHALL BE:  
1 PLACE MACHINING  $\pm 0.3$   
1 PLACE FABRICATION  $\pm 1.5$   
2 PLACE  $\pm 0.03$  GENERAL  
 $\pm 0.03$  BETWEEN DOWELS  
 $\pm 0.13$  TO SCREW HOLES

NOTES: ALL DIMENSIONS METRIC UNLESS OTHERWISE NOTED.

MATERIAL: 4140 OR EQUIVALENT

NAAMS CODE	DIM "V" +1.5/-0.0	MAX OAL (REF)	Weight kg*	Dim. "A"	Dim. "B"	Dim. "C"	Dim. "D"	Dim. "E"	Dim. "F"	Dim. "G"	Dim. "H"	Dim. "I"	Dim. "J"	Dim. "K"	Dim. "L"	Dim. "M"
ACA110	155.0 (6.10)	192.0 (7.56)	1.9 (4.2)	145.0 (5.709)	130.00 (5.118)	115.00 (4.528)	100.00 (3.937)	85.00 (3.346)								
ACA111	185.0 (7.28)	222.0 (8.84)	2.2 (4.8)	175.00 (6.890)	160.00 (6.299)	145.00 (5.709)	130.00 (5.118)	115.00 (4.528)	100.00 (3.937)	85.00 (3.346)						
ACA112	215.0 (8.46)	252.0 (9.92)	2.4 (5.4)	205.00 (8.071)	190.00 (7.480)	175.00 (6.890)	160.00 (6.299)	145.00 (5.709)	130.00 (5.118)	115.00 (4.528)	100.00 (3.937)	85.00 (3.346)				
ACA113	245.0 (9.65)	282.0 (11.10)	2.7 (6.0)	235.00 (9.252)	220.00 (8.661)	205.00 (8.071)	190.00 (7.480)	175.00 (6.890)	160.00 (6.299)	145.00 (5.709)	130.00 (5.118)	115.00 (4.528)	100.00 (3.937)	85.00 (3.346)		
ACA114	275.0 (10.83)	312.0 (12.28)	3.0 (6.5)	265.00 (10.433)	250.00 (9.843)	235.00 (9.252)	220.00 (8.661)	205.00 (8.071)	190.00 (7.480)	175.00 (6.890)	160.00 (6.299)	145.00 (5.709)	130.00 (5.118)	115.00 (4.528)	100.00 (3.937)	85.00 (3.346)
ACA115	305.0 (12.00)	342.0 (13.46)	3.2 (7.1)	295.00 (11.614)	280.00 (11.024)	265.00 (10.433)	250.00 (9.843)	235.00 (9.252)	220.00 (8.661)	205.00 (8.071)	190.00 (7.480)	175.00 (6.890)	160.00 (6.299)	145.00 (5.709)	130.00 (5.118)	115.00 (4.528)
ACA116	335.0 (13.19)	372.0 (14.65)	3.6 (7.9)	325.00 (12.795)	310.00 (12.205)	295.00 (11.614)	280.00 (11.024)	265.00 (10.433)	250.00 (9.843)	235.00 (9.252)	220.00 (8.661)	205.00 (8.071)	190.00 (7.480)	175.00 (6.890)	160.00 (6.299)	145.00 (5.709)
ACA117	365.0 (14.37)	402.0 (15.83)	3.9 (8.5)	355.00 (13.976)	340.00 (13.386)	325.00 (12.795)	310.00 (12.205)	295.00 (11.614)	280.00 (11.024)	265.00 (10.433)	250.00 (9.843)	235.00 (9.252)	220.00 (8.661)	205.00 (8.071)	190.00 (7.480)	175.00 (6.890)
ACA118	395.0 (15.55)	432.0 (17.01)	4.1 (9.1)	385.00 (15.157)	370.00 (14.567)	355.00 (13.976)	340.00 (13.386)	325.00 (12.795)	310.00 (12.205)	295.00 (11.614)	280.00 (11.024)	265.00 (10.433)	250.00 (9.843)	235.00 (9.252)	220.00 (8.661)	205.00 (8.071)

A

B

D

E

F

C

DOWEL

NAAMS CODE	Dim. "N"	Dim. "O"	Dim. "P"	Dim. "Q"	Dim. "R"	Dim. "S"	Dim. "T"	Dim. "U"
ACA115	100.00 (3.937)	85.00 (3.346)						
ACA116	130.00 (5.118)	115.00 (4.528)	100.00 (3.937)	85.00 (3.346)				
ACA117	160.00 (6.299)	145.00 (5.709)	130.00 (5.118)	115.00 (4.528)	100.00 (3.937)	85.00 (3.346)		
ACA118	190.00 (7.480)	175.00 (6.890)	160.00 (6.299)	145.00 (5.709)	130.00 (5.118)	115.00 (4.528)	100.00 (3.937)	85.00 (3.346)

DOWEL

\* Weight of arm as shown. Actual weight may vary due to variations in mounting details.

SEE DRAWING ON PREVIOUS PAGE

# POWER CLAMP ARMS 80/90 SERIES (25mm OFFSET - MACHINED)

E

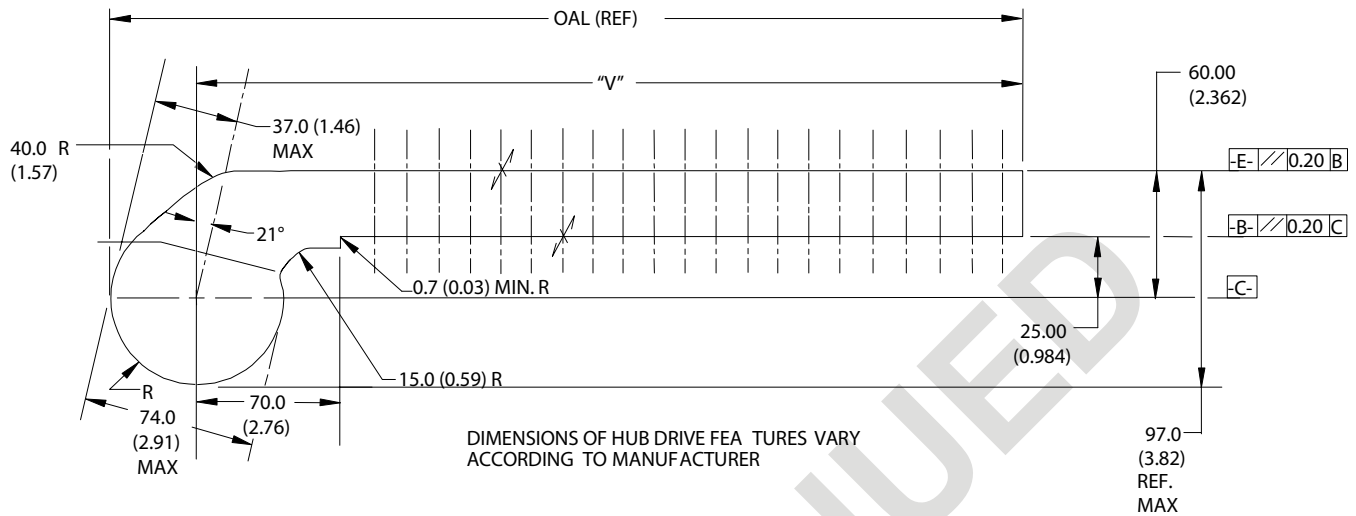

B

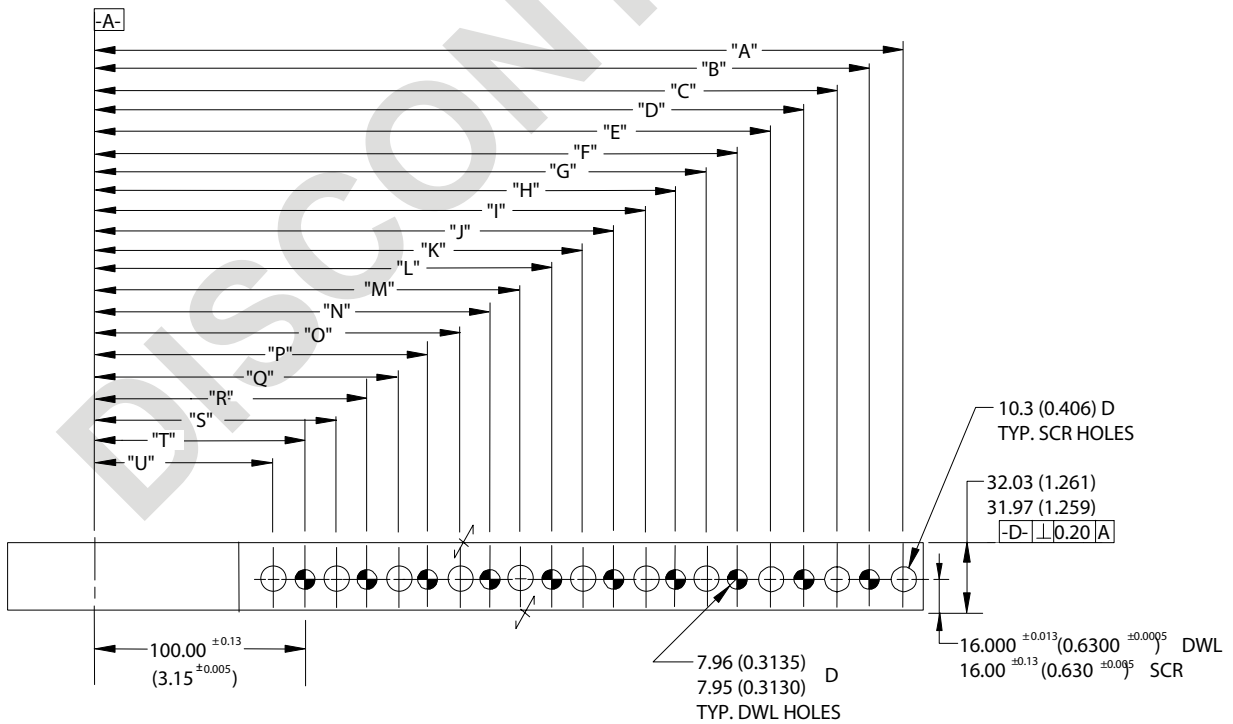

C

STAMP OR ETCH THE NAAMS CODE NUMBER AND THE CLAMP ARM MANUFACTURER'S NUMBER, IF DIFFERENT, ON THE SIDE OF THE ARM.

PAINT AS PRESCRIBED ON PAGE G-1.2

CLEARANCE HOLES G, I, K, M, O, Q, S AND U ARE OPTIONAL UNTIL FEBRUARY 1, 2006 AND MANDATORY THEREAFTER.

TABULATED INFORMATION ON FOLLOWING PAGE

D

A

# POWER CLAMP ARMS 80/90 SERIES (25mm OFFSET - MACHINED)

G

MAXIMUM ALLOWABLE ROUGHNESS SHALL BE:  
1 PLACE FINISH DIMENSIONS TO BE 6 MICRONS  
2 PLACE FINISH DIMENSIONS TO BE 3 MICRONS  
3 PLACE FINISH DIMENSIONS TO BE 1.6 MICRONS

EXCEPT AS NOTED TOLERANCES SHALL BE:  
1 PLACE MACHINING  $\pm 0.3$   
1 PLACE FABRICATION  $\pm 1.5$   
2 PLACE  $\pm 0.03$  GENERAL  
 $\pm 0.03$  BETWEEN DOWELS  
 $\pm 0.13$  TO SCREW HOLES

NOTES: ALL DIMENSIONS METRIC UNLESS OTHERWISE NOTED.

MATERIAL: 4140 OR EQUIVALENT

NAAMS CODE	DIM "V" +1.5/-0.0	MAX OAL (REF)	Weight kg*	Dim. "A"	Dim. "B"	Dim. "C"	Dim. "D"	Dim. "E"	Dim. "F"	Dim. "G"	Dim. "H"	Dim. "I"	Dim. "J"	Dim. "K"	Dim. "L"	Dim. "M"
ACA130	155.0 (6.10)	192.0 (7.56)	2.1 (4.6)	145.0 (5.709)	130.00 (5.118)	115.00 (4.528)	100.00 (3.937)	85.00 (3.346)								
ACA131	185.0 (7.28)	222.0 (8.84)	2.3 (5.0)	175.00 (6.890)	160.00 (6.299)	145.00 (5.709)	130.00 (5.118)	115.00 (4.528)	100.00 (3.937)	85.00 (3.346)						
ACA132	215.0 (8.46)	252.0 (9.92)	2.5 (5.6)	205.00 (8.071)	190.00 (7.480)	175.00 (6.890)	160.00 (6.299)	145.00 (5.709)	130.00 (5.118)	115.00 (4.528)	100.00 (3.937)	85.00 (3.346)				
ACA133	245.0 (9.65)	282.0 (11.10)	2.7 (6.0)	235.00 (9.252)	220.00 (8.661)	205.00 (8.071)	190.00 (7.480)	175.00 (6.890)	160.00 (6.299)	145.00 (5.709)	130.00 (5.118)	115.00 (4.528)	100.00 (3.937)	85.00 (3.346)		
ACA134	275.0 (10.83)	312.0 (12.28)	3.0 (6.6)	265.00 (10.433)	250.00 (9.843)	235.00 (9.252)	220.00 (8.661)	205.00 (8.071)	190.00 (7.480)	175.00 (6.890)	160.00 (6.299)	145.00 (5.709)	130.00 (5.118)	115.00 (4.528)	100.00 (3.937)	85.00 (3.346)
ACA135	305.0 (12.00)	342.0 (13.46)	3.2 (7.0)	295.00 (11.614)	280.00 (11.024)	265.00 (10.433)	250.00 (9.843)	235.00 (9.252)	220.00 (8.661)	205.00 (8.071)	190.00 (7.480)	175.00 (6.890)	160.00 (6.299)	145.00 (5.709)	130.00 (5.118)	115.00 (4.528)
ACA136	335.0 (13.19)	372.0 (14.65)	3.4 (7.6)	325.00 (12.795)	310.00 (12.205)	295.00 (11.614)	280.00 (11.024)	265.00 (10.433)	250.00 (9.843)	235.00 (9.252)	220.00 (8.661)	205.00 (8.071)	190.00 (7.480)	175.00 (6.890)	160.00 (6.299)	145.00 (5.709)
ACA137	365.0 (14.37)	402.0 (15.83)	3.8 (8.0)	355.00 (13.976)	340.00 (13.386)	325.00 (12.795)	310.00 (12.205)	295.00 (11.614)	280.00 (11.024)	265.00 (10.433)	250.00 (9.843)	235.00 (9.252)	220.00 (8.661)	205.00 (8.071)	190.00 (7.480)	175.00 (6.890)
ACA138	395.0 (15.55)	432.0 (17.01)	3.9 (8.6)	385.00 (15.157)	370.00 (14.567)	355.00 (13.976)	340.00 (13.386)	325.00 (12.795)	310.00 (12.205)	295.00 (11.614)	280.00 (11.024)	265.00 (10.433)	250.00 (9.843)	235.00 (9.252)	220.00 (8.661)	205.00 (8.071)

A  
B  
D  
E  
F

C

DOWEL

NAAMS CODE	Dim. "N"	Dim. "O"	Dim. "P"	Dim. "Q"	Dim. "R"	Dim. "S"	Dim. "T"	Dim. "U"
ACA135	100.00 (3.937)	85.00 (3.346)						
ACA136	130.00 (5.118)	115.00 (4.528)	100.00 (3.937)	85.00 (3.346)				
ACA137	160.00 (6.299)	145.00 (5.709)	130.00 (5.118)	115.00 (4.528)	100.00 (3.937)	85.00 (3.346)		
ACA138	190.00 (7.480)	175.00 (6.890)	160.00 (6.299)	145.00 (5.709)	130.00 (5.118)	115.00 (4.528)	100.00 (3.937)	85.00 (3.346)

DOWEL

\* Weight of arm as shown. Actual weight may vary due to variations in mounting details.

SEE DRAWING ON PREVIOUS PAGE

# POWER CLAMP ARMS 80/90 SERIES (70mm OFFSET - MACHINED)

E

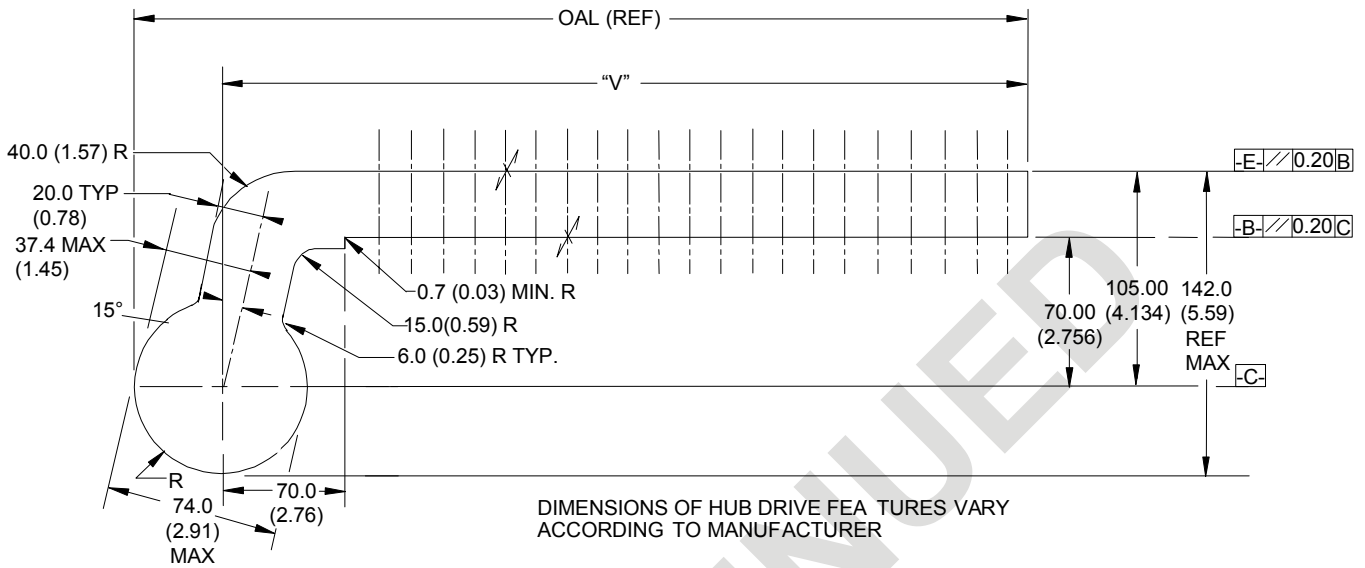

B

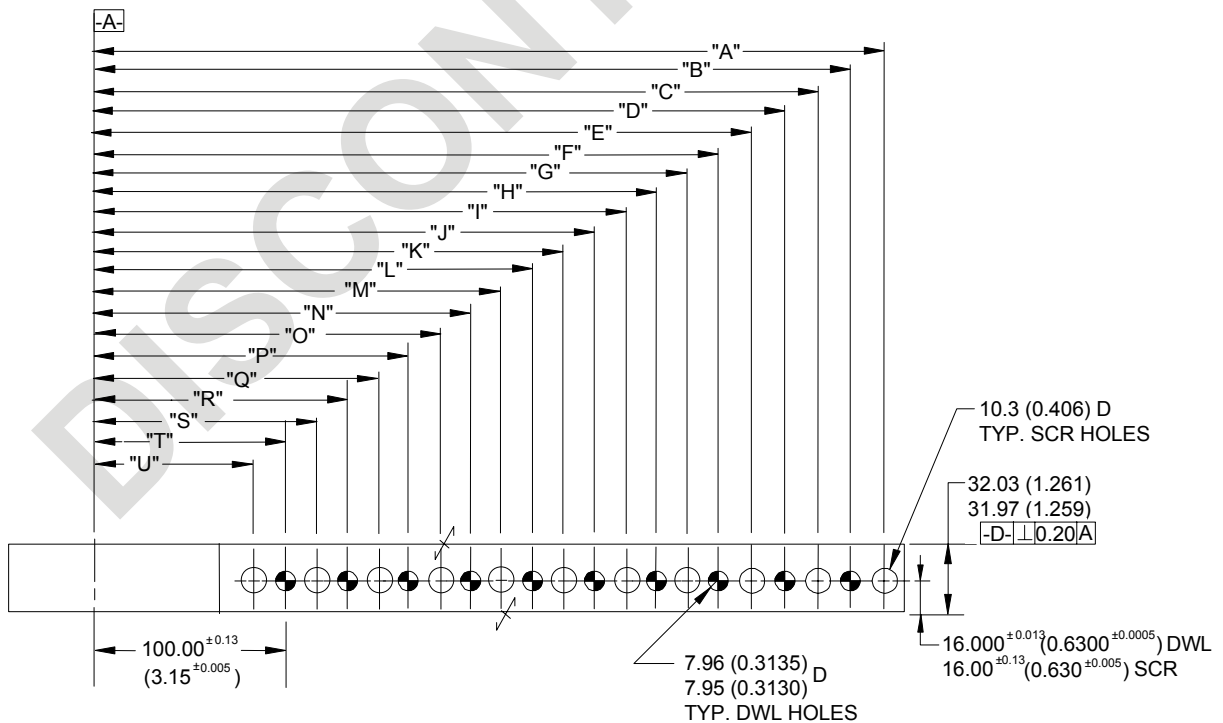

C

STAMP OR ETCH THE NAAMS CODE NUMBER AND THE CLAMP ARM MANUFACTURER'S NUMBER, IF DIFFERENT, ON THE SIDE OF THE ARM.

PAINT AS PRESCRIBED ON PAGE G-1.2

CLEARANCE HOLES G, I, K, M, O, Q, S AND U ARE OPTIONAL UNTIL FEBRUARY 1, 2006 AND MANDATORY THEREAFTER.

TABULATED INFORMATION ON FOLLOWING PAGE

D

A

# POWER CLAMP ARMS 80/90 SERIES (70mm OFFSET - MACHINED)

GLOBAL STANDARD COMPONENTS



TM

Assembly

11/10/10

G

MAXIMUM ALLOWABLE ROUGHNESS SHALL BE:  
 1 PLACE FINISH DIMENSIONS TO BE 6 MICRONS  
 2 PLACE FINISH DIMENSIONS TO BE 3 MICRONS  
 3 PLACE FINISH DIMENSIONS TO BE 1.6 MICRONS

EXCEPT AS NOTED TOLERANCES SHALL BE:

- 1 PLACE MACHINING  $\pm 0.3$
- 1 PLACE FABRICATION  $\pm 1.5$
- 2 PLACE  $\pm 0.03$  GENERAL  
 $\pm 0.03$  BETWEEN DOWELS  
 $\pm 0.13$  TO SCREW HOLES

NOTES: ALL DIMENSIONS METRIC UNLESS OTHERWISE NOTED.

MATERIAL: 4140 OR EQUIVALENT

NAAMS CODE	DIM "V" +1.5/-0.0	MAX OAL (REF)	Weight kg*	Dim. "A"	Dim. "B"	Dim. "C"	Dim. "D"	Dim. "E"	Dim. "F"	Dim. "G"	Dim. "H"	Dim. "I"	Dim. "J"	Dim. "K"	Dim. "L"	Dim. "M"
ACA150	155.0 (6.10)	192.0 (7.56)	2.4 (5.3)	145.0 (5.709)	130.00 (5.118)	115.00 (4.528)	100.00 (3.937)	85.00 (3.346)								
ACA151	185.0 (7.28)	222.0 (8.84)	2.6 (5.7)	175.00 (6.890)	160.00 (6.299)	145.00 (5.709)	130.00 (5.118)	115.00 (4.528)	100.00 (3.937)	85.00 (3.346)						
ACA152	215.0 (8.46)	252.0 (9.92)	2.8 (6.3)	205.00 (8.071)	190.00 (7.480)	175.00 (6.890)	160.00 (6.299)	145.00 (5.709)	130.00 (5.118)	115.00 (4.528)	100.00 (3.937)	85.00 (3.346)				
ACA153	245.0 (9.65)	282.0 (11.10)	3.0 (6.7)	235.00 (9.252)	220.00 (8.661)	205.00 (8.071)	190.00 (7.480)	175.00 (6.890)	160.00 (6.299)	145.00 (5.709)	130.00 (5.118)	115.00 (4.528)	100.00 (3.937)	85.00 (3.346)		
ACA154	275.0 (10.83)	312.0 (12.28)	3.3 (7.3)	265.00 (10.433)	250.00 (9.843)	235.00 (9.252)	220.00 (8.661)	205.00 (8.071)	190.00 (7.480)	175.00 (6.890)	160.00 (6.299)	145.00 (5.709)	130.00 (5.118)	115.00 (4.528)	100.00 (3.937)	85.00 (3.346)
ACA155	305.0 (12.00)	342.0 (13.46)	3.5 (7.7)	295.00 (11.614)	280.00 (11.024)	265.00 (10.433)	250.00 (9.843)	235.00 (9.252)	220.00 (8.661)	205.00 (8.071)	190.00 (7.480)	175.00 (6.890)	160.00 (6.299)	145.00 (5.709)	130.00 (5.118)	115.00 (4.528)
ACA156	335.0 (13.19)	372.0 (14.65)	3.7 (8.3)	325.00 (12.795)	310.00 (12.205)	295.00 (11.614)	280.00 (11.024)	265.00 (10.433)	250.00 (9.843)	235.00 (9.252)	220.00 (8.661)	205.00 (8.071)	190.00 (7.480)	175.00 (6.890)	160.00 (6.299)	145.00 (5.709)
ACA157	365.0 (14.37)	402.0 (15.83)	3.9 (8.6)	355.00 (13.976)	340.00 (13.386)	325.00 (12.795)	310.00 (12.205)	295.00 (11.614)	280.00 (11.024)	265.00 (10.433)	250.00 (9.843)	235.00 (9.252)	220.00 (8.661)	205.00 (8.071)	190.00 (7.480)	175.00 (6.890)
ACA158	395.0 (15.55)	432.0 (17.01)	4.2 (9.2)	385.00 (15.157)	370.00 (14.567)	355.00 (13.976)	340.00 (13.386)	325.00 (12.795)	310.00 (12.205)	295.00 (11.614)	280.00 (11.024)	265.00 (10.433)	250.00 (9.843)	235.00 (9.252)	220.00 (8.661)	205.00 (8.071)

A

B

D

E

F

C

DOWEL

NAAMS CODE	Dim. "N"	Dim. "O"	Dim. "P"	Dim. "Q"	Dim. "R"	Dim. "S"	Dim. "T"	Dim. "U"
ACA155	100.00 (3.937)	85.00 (3.346)						
ACA156	130.00 (5.118)	115.00 (4.528)	100.00 (3.937)	85.00 (3.346)				
ACA157	160.00 (6.299)	145.00 (5.709)	130.00 (5.118)	115.00 (4.528)	100.00 (3.937)	85.00 (3.346)		
ACA158	190.00 (7.480)	175.00 (6.890)	160.00 (6.299)	145.00 (5.709)	130.00 (5.118)	115.00 (4.528)	100.00 (3.937)	85.00 (3.346)

DOWEL

\* Weight of arm as shown. Actual weight may vary due to variations in mounting details.

SEE DRAWING ON PREVIOUS PAGE

# POWER CLAMP ARMS 80/90 SERIES (120mm OFFSET - MACHINED)

E

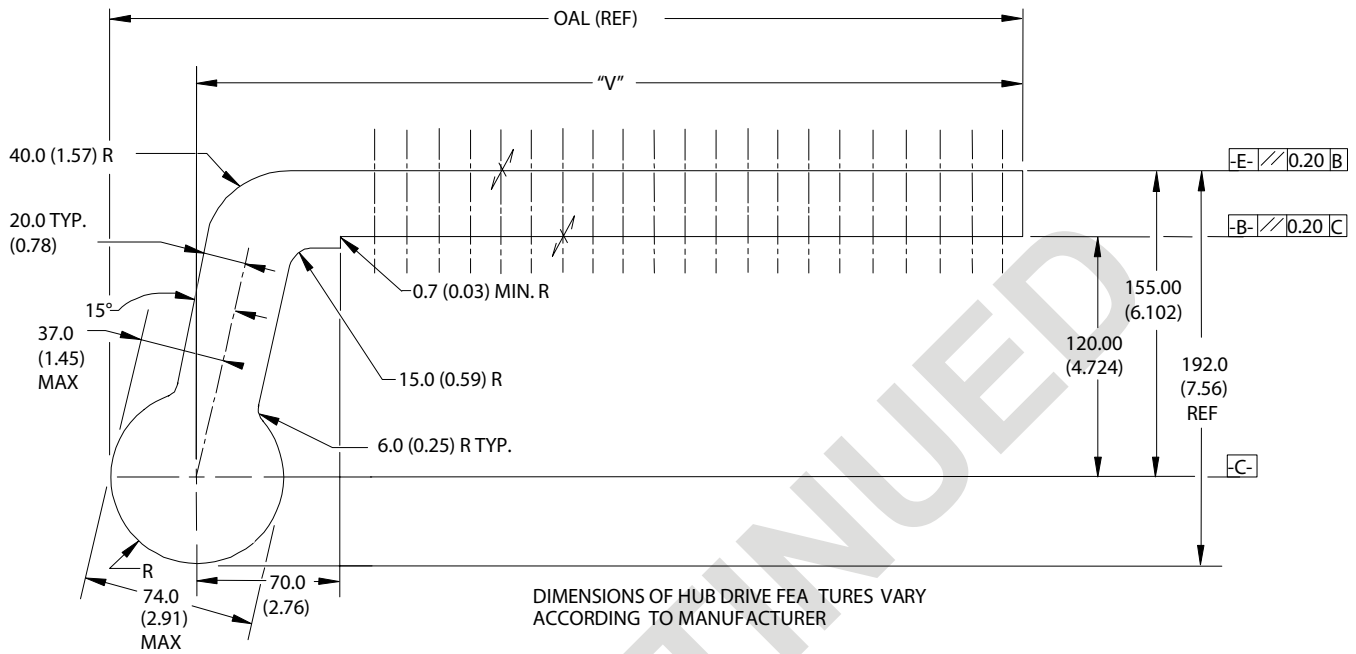

B

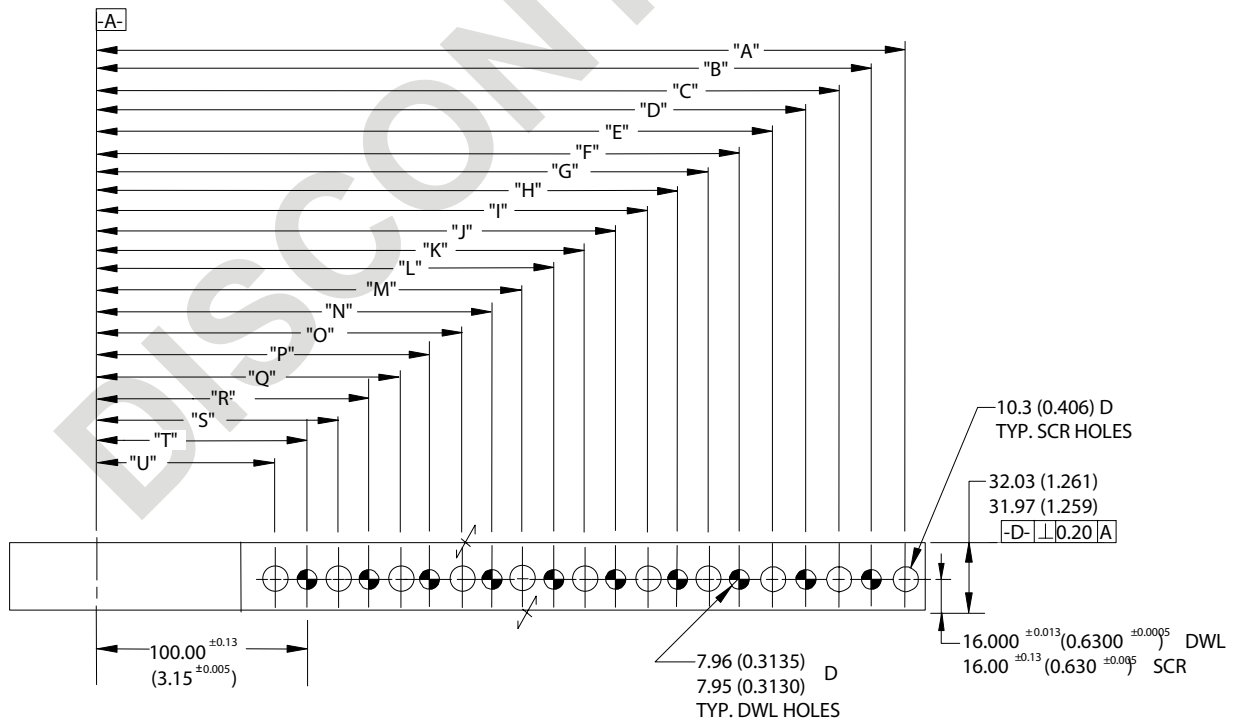

C

STAMP OR ETCH THE NAAMS CODE NUMBER AND THE CLAMP ARM MANUFACTURER'S NUMBER, IF DIFFERENT, ON THE SIDE OF THE ARM.

PAINT AS PRESCRIBED ON PAGE G-1.2

CLEARANCE HOLES G, I, K, M, O, Q, S AND U ARE OPTIONAL UNTIL FEBRUARY 1, 2006 AND MANDATORY THEREAFTER.

TABULATED INFORMATION ON FOLLOWING PAGE

D

A



# POWER CLAMP ARMS 80/90 SERIES (120mm OFFSET - MACHINED)

GLOBAL STANDARD COMPONENTS



Assembly

11/10/10

G

MAXIMUM ALLOWABLE ROUGHNESS SHALL BE:  
 1 PLACE FINISH DIMENSIONS TO BE 6 MICRONS  
 2 PLACE FINISH DIMENSIONS TO BE 3 MICRONS  
 3 PLACE FINISH DIMENSIONS TO BE 1.6 MICRONS

EXCEPT AS NOTED TOLERANCES SHALL BE:

- 1 PLACE MACHINING  $\pm 0.3$
- 1 PLACE FABRICATION  $\pm 1.5$
- 2 PLACE  $\pm 0.03$  GENERAL  
 $\pm 0.03$  BETWEEN DOWELS  
 $\pm 0.13$  TO SCREW HOLES

NOTES: ALL DIMENSIONS METRIC UNLESS OTHERWISE NOTED.

MATERIAL: 4140 OR EQUIVALENT

NAAMS CODE	DIM "V" +1.5/-0.0	MAX OAL (REF)	Weight kg*	Dim. "A"	Dim. "B"	Dim. "C"	Dim. "D"	Dim. "E"	Dim. "F"	Dim. "G"	Dim. "H"	Dim. "I"	Dim. "J"	Dim. "K"	Dim. "L"	Dim. "M"
ACA170	155.0 (6.10)	192.0 (7.56)	2.8 (6.2)	145.0 (5.709)	130.00 (5.118)	115.00 (4.528)	100.00 (3.937)	85.00 (3.346)								
ACA171	185.0 (7.28)	222.0 (8.84)	3.0 (6.6)	175.00 (6.890)	160.00 (6.299)	145.00 (5.709)	130.00 (5.118)	115.00 (4.528)	100.00 (3.937)	85.00 (3.346)						
ACA172	215.0 (8.46)	252.0 (9.92)	3.2 (7.2)	205.00 (8.071)	190.00 (7.480)	175.00 (6.890)	160.00 (6.299)	145.00 (5.709)	130.00 (5.118)	115.00 (4.528)	100.00 (3.937)	85.00 (3.346)				
ACA173	245.0 (9.65)	282.0 (11.10)	3.4 (7.5)	235.00 (9.252)	220.00 (8.661)	205.00 (8.071)	190.00 (7.480)	175.00 (6.890)	160.00 (6.299)	145.00 (5.709)	130.00 (5.118)	115.00 (4.528)	100.00 (3.937)	85.00 (3.346)		
ACA174	275.0 (10.83)	312.0 (12.28)	3.7 (8.1)	265.00 (10.433)	250.00 (9.843)	235.00 (9.252)	220.00 (8.661)	205.00 (8.071)	190.00 (7.480)	175.00 (6.890)	160.00 (6.299)	145.00 (5.709)	130.00 (5.118)	115.00 (4.528)	100.00 (3.937)	85.00 (3.346)
ACA175	305.0 (12.00)	342.0 (13.46)	3.9 (8.5)	295.00 (11.614)	280.00 (11.024)	265.00 (10.433)	250.00 (9.843)	235.00 (9.252)	220.00 (8.661)	205.00 (8.071)	190.00 (7.480)	175.00 (6.890)	160.00 (6.299)	145.00 (5.709)	130.00 (5.118)	115.00 (4.528)
ACA176	335.0 (13.19)	372.0 (14.65)	4.1 (9.1)	325.00 (12.795)	310.00 (12.205)	295.00 (11.614)	280.00 (11.024)	265.00 (10.433)	250.00 (9.843)	235.00 (9.252)	220.00 (8.661)	205.00 (8.071)	190.00 (7.480)	175.00 (6.890)	160.00 (6.299)	145.00 (5.709)
ACA177	365.0 (14.37)	402.0 (15.83)	4.3 (9.5)	355.00 (13.976)	340.00 (13.386)	325.00 (12.795)	310.00 (12.205)	295.00 (11.614)	280.00 (11.024)	265.00 (10.433)	250.00 (9.843)	235.00 (9.252)	220.00 (8.661)	205.00 (8.071)	190.00 (7.480)	175.00 (6.890)
ACA178	395.0 (15.55)	432.0 (17.01)	4.6 (10.1)	385.00 (15.157)	370.00 (14.567)	355.00 (13.976)	340.00 (13.386)	325.00 (12.795)	310.00 (12.205)	295.00 (11.614)	280.00 (11.024)	265.00 (10.433)	250.00 (9.843)	235.00 (9.252)	220.00 (8.661)	205.00 (8.071)

A

B

D

E

F

C

DOWEL

NAAMS CODE	Dim. "N"	Dim. "O"	Dim. "P"	Dim. "Q"	Dim. "R"	Dim. "S"	Dim. "T"	Dim. "U"
ACA175	100.00 (3.937)	85.00 (3.346)						
ACA176	130.00 (5.118)	115.00 (4.528)	100.00 (3.937)	85.00 (3.346)				
ACA177	160.00 (6.299)	145.00 (5.709)	130.00 (5.118)	115.00 (4.528)	100.00 (3.937)	85.00 (3.346)		
ACA178	190.00 (7.480)	175.00 (6.890)	160.00 (6.299)	145.00 (5.709)	130.00 (5.118)	115.00 (4.528)	100.00 (3.937)	85.00 (3.346)

DOWEL

\* Weight of arm as shown. Actual weight may vary due to variations in mounting details.

SEE DRAWING ON PREVIOUS PAGE

# ENCLOSED CLAMP HOLE 50 SERIES PATTERN #1

B

EXCEPT AS NOTED METRIC TOLERANCES SHALL BE:  
 2 PLACE ± 0.03 GENERAL  
 ± 0.03 BETWEEN DOWELS  
 ± 0.13 TO SCREW HOLES

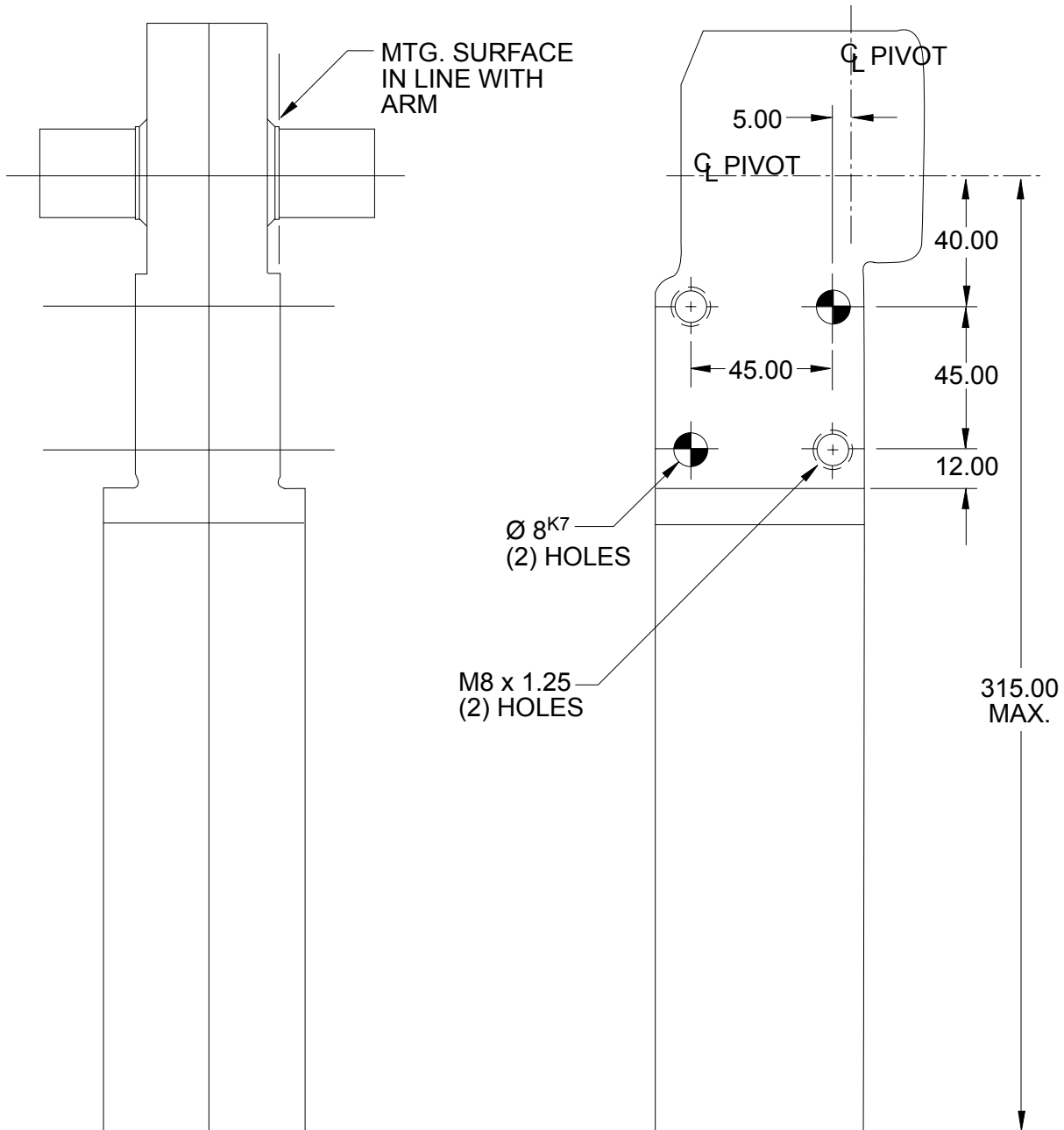

A

# ENCLOSED CLAMP HOLE 60 SERIES PATTERN #2

**B**

EXCEPT AS NOTED METRIC TOLERANCES SHALL BE:  
 2 PLACE ± 0.03 GENERAL  
 ± 0.03 BETWEEN DOWELS  
 ± 0.13 TO SCREW HOLES

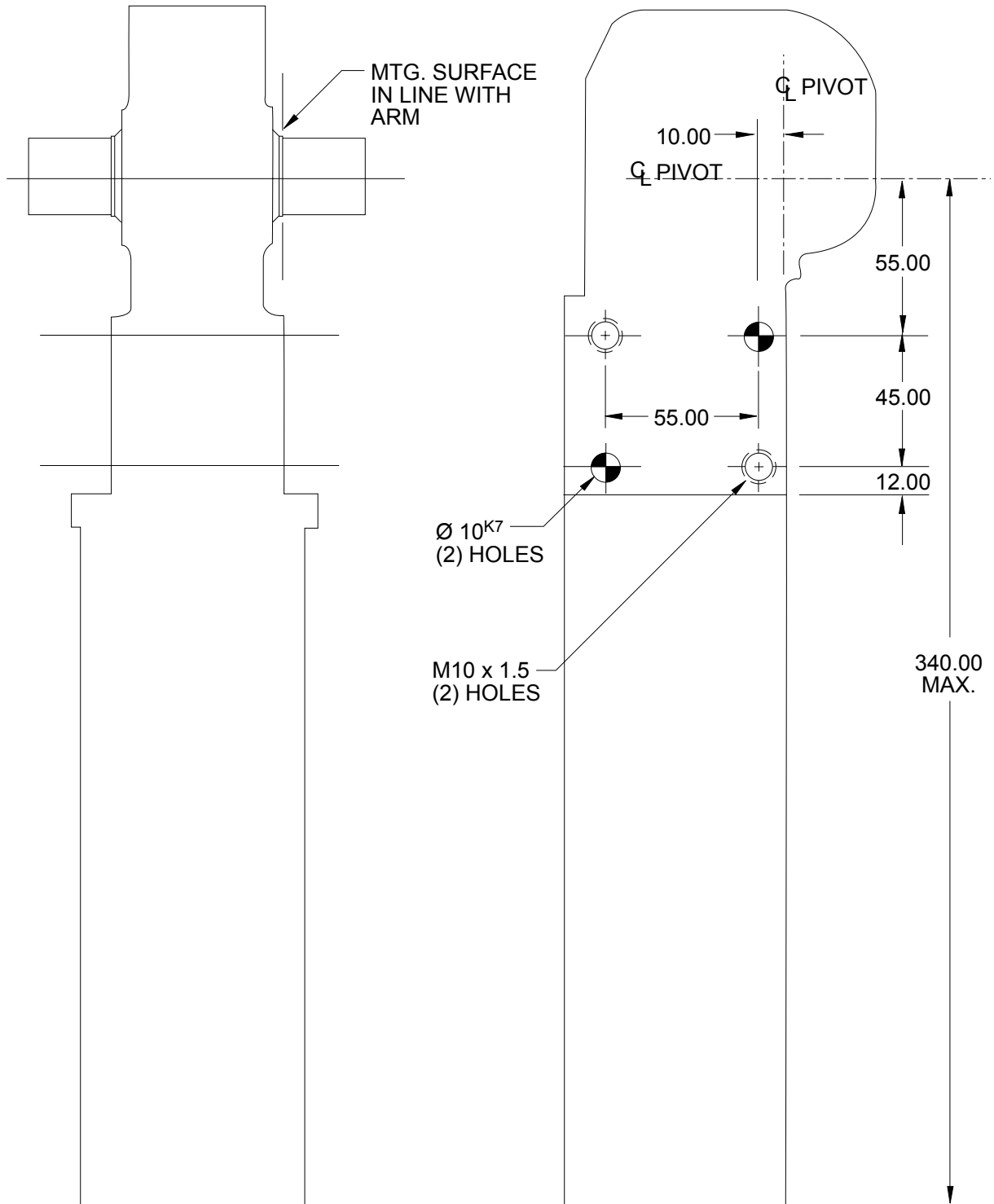

**A**

# ENCLOSED CLAMP HOLE 80/90 SERIES PATTERN #3

B

EXCEPT AS NOTED METRIC TOLERANCES SHALL BE:  
 2 PLACE ± 0.03 GENERAL  
 ± 0.03 BETWEEN DOWELS  
 ± 0.13 TO SCREW HOLES

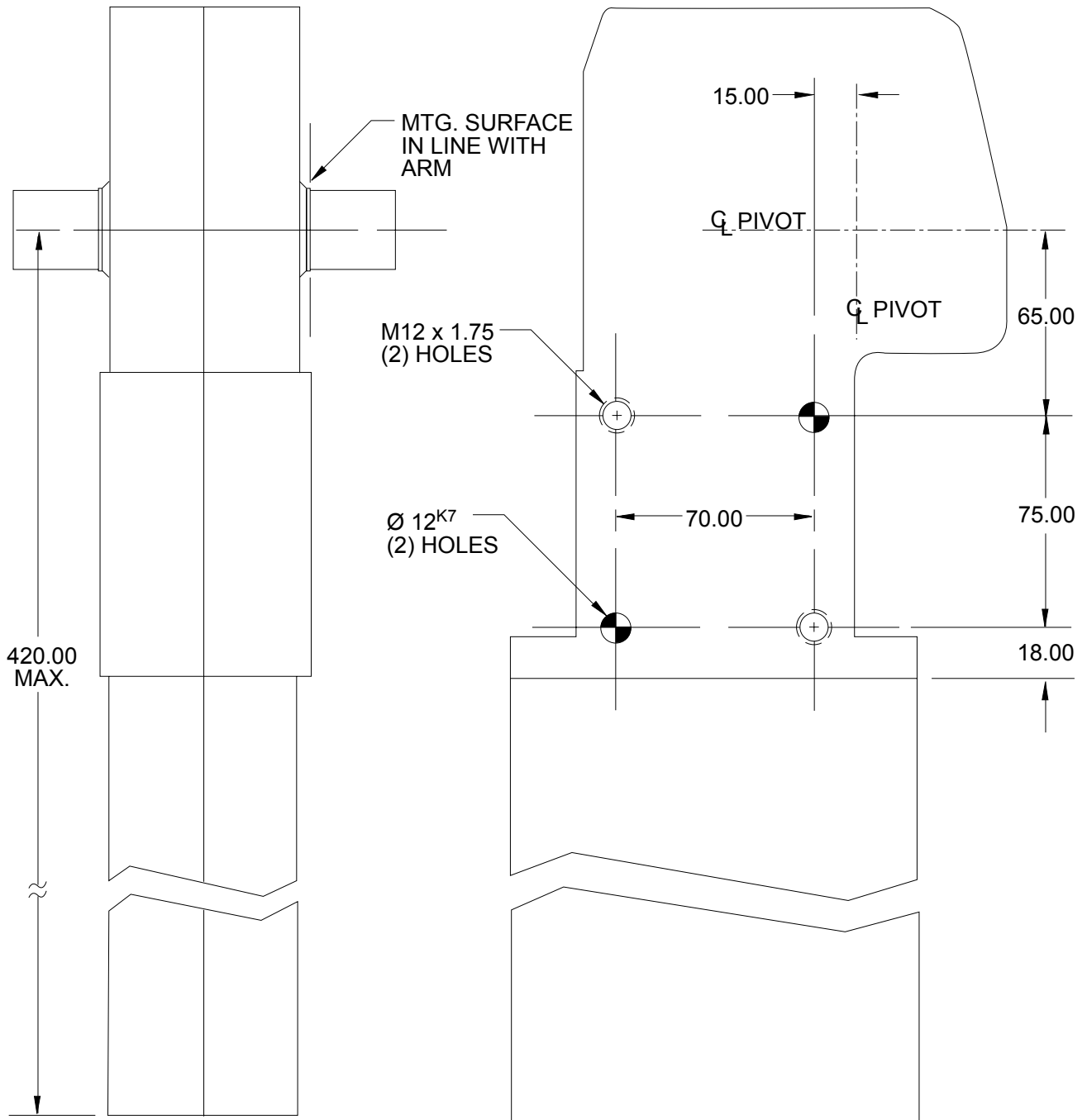

A

# POWER CLAMP ARMS BLANKS

## 50 SERIES

(STRAIGHT) (FULL METRIC)

GLOBAL STANDARD COMPONENTS



Assembly

11/10/10

D

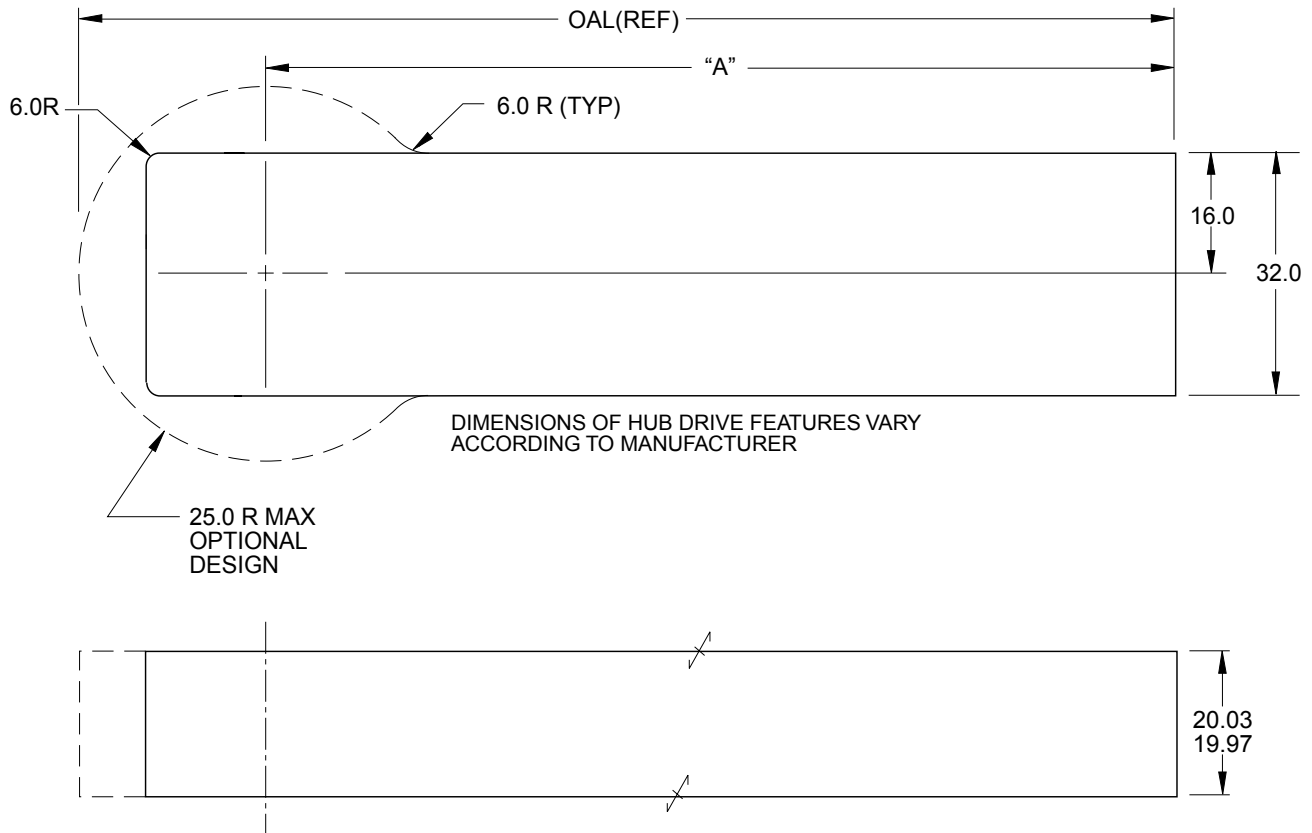

A

STAMP OR ETCH THE NAAMS CODE NUMBER AND THE CLAMP ARM MANUFACTURER'S NUMBER, IF DIFFERENT, ON THE SIDE OF THE ARM.

EXCEPT AS NOTED TOLERANCES SHALL BE:  
1 PLACE FABRICATION  $\pm 1.5$

MATERIAL: SAE 4140 or SAE 1045

NOTES: ALL DIMENSIONS METRIC UNLESS OTHERWISE NOTED.

C

NAAMS CODE	DIM. "A"	MAX OAL (REF)	WEIGHT kg
ACA201M	90.0	115.0	0.5
ACA202M	120.0	145.0	0.7
ACA203M	150.0	175.0	0.8

B

# POWER CLAMP ARMS BLANKS

## 50 SERIES

(20mm OFFSET) (FULL METRIC)

GLOBAL STANDARD COMPONENTS



Assembly

11/10/10

D

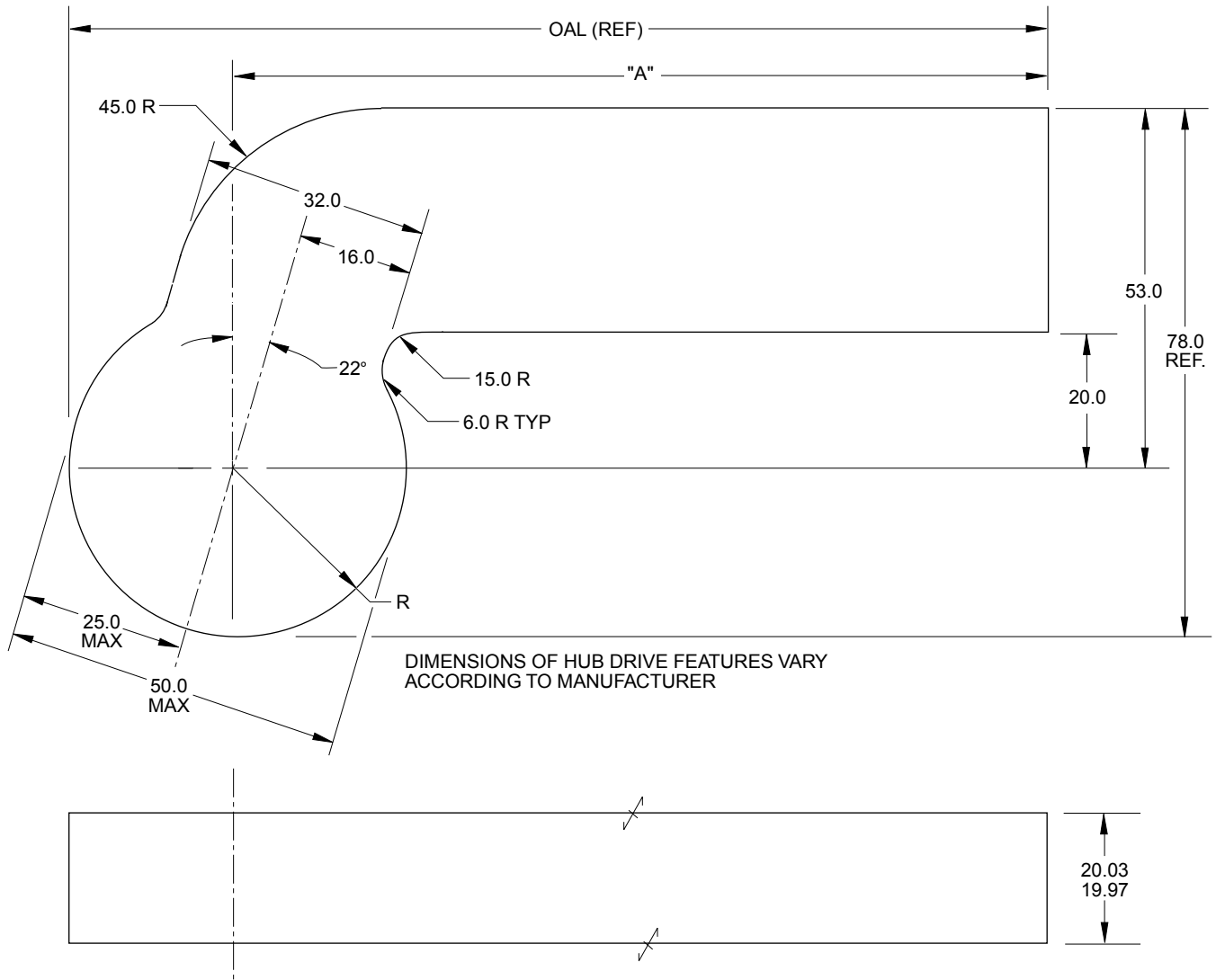

A

STAMP OR ETCH THE NAAMS CODE NUMBER AND THE CLAMP ARM MANUFACTURER'S NUMBER, IF DIFFERENT, ON THE SIDE OF THE ARM.

EXCEPT AS NOTED TOLERANCES SHALL BE:

1 PLACE FABRICATION  $\pm 1.5$

MATERIAL: SAE 4140 or SAE 1045

NOTES: ALL DIMENSIONS METRIC UNLESS OTHERWISE NOTED.

C

NAAMS CODE	DIM. "A"	MAX OAL (REF)	WEIGHT kg
ACA211M	90.0	115.0	0.6
ACA212M	120.0	145.0	0.8
ACA213M	150.0	175.0	0.9

B

# POWER CLAMP ARMS BLANKS

## 50 SERIES

(45mm OFFSET) (FULL METRIC)

GLOBAL STANDARD COMPONENTS



Assembly

11/10/10

D

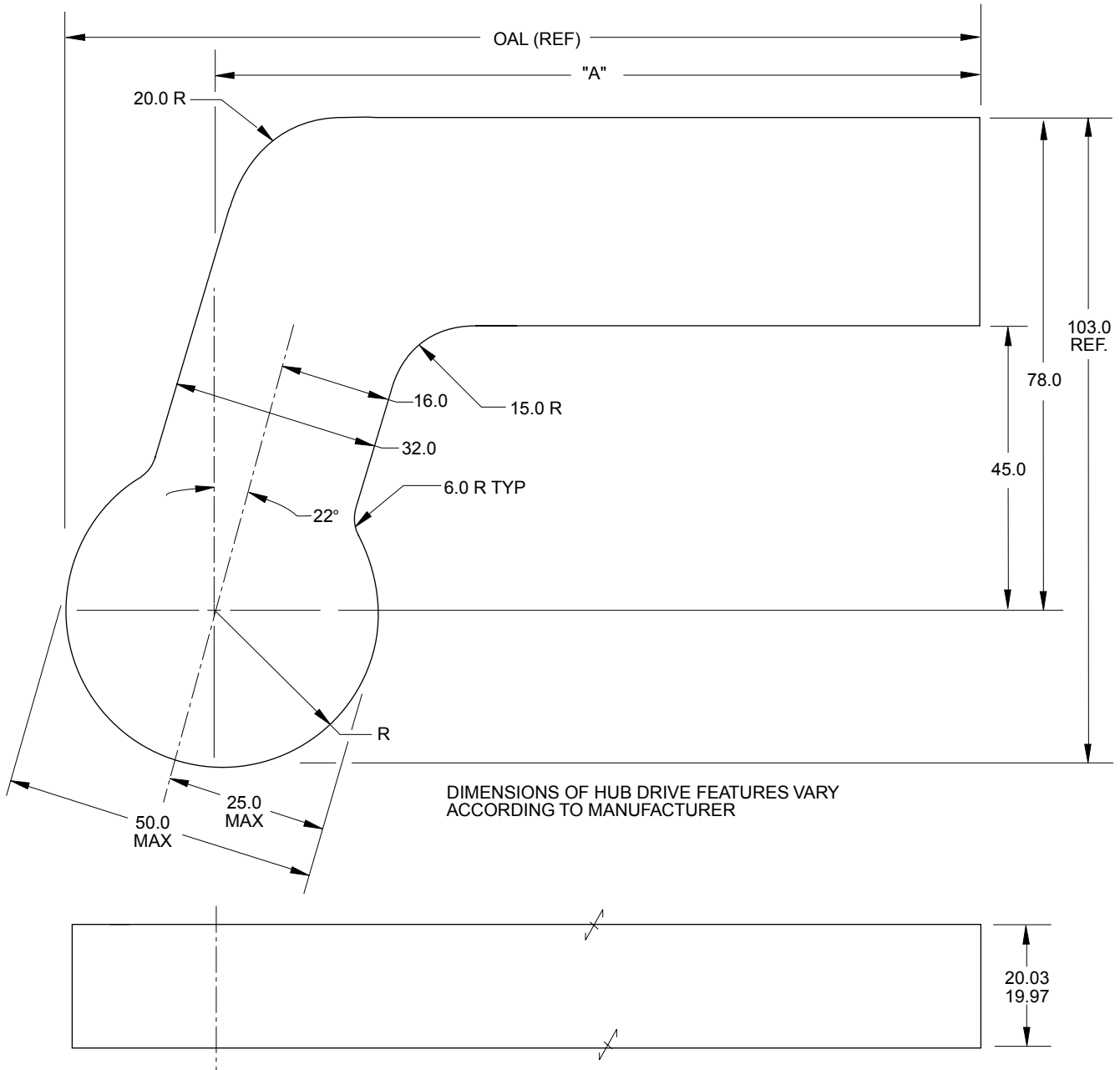

A

STAMP OR ETCH THE NAAMS CODE NUMBER AND THE CLAMP ARM MANUFACTURER'S NUMBER, IF DIFFERENT, ON THE SIDE OF THE ARM.

MATERIAL: SAE 4140 or SAE 1045

EXCEPT AS NOTED TOLERANCES SHALL BE:

1 PLACE FABRICATION  $\pm 1.5$

NOTES: ALL DIMENSIONS METRIC UNLESS OTHERWISE NOTED.

NAAMS CODE	DIM. "A"	MAX OAL (REF)	WEIGHT kg
ACA221M	90.0	115.0	0.7
ACA222M	120.0	145.0	0.9
ACA223M	150.0	175.0	1.0

C

B

# POWER CLAMP ARMS 50 SERIES

(STRAIGHT) (MACHINED - FULL METRIC)

GLOBAL STANDARD COMPONENTS



Assembly

11/10/10

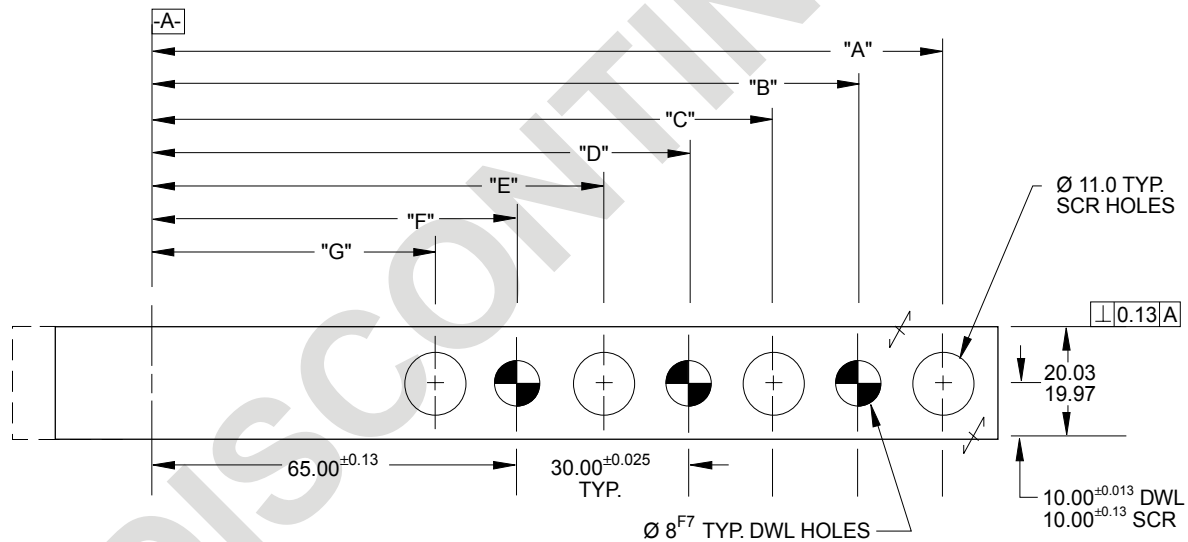
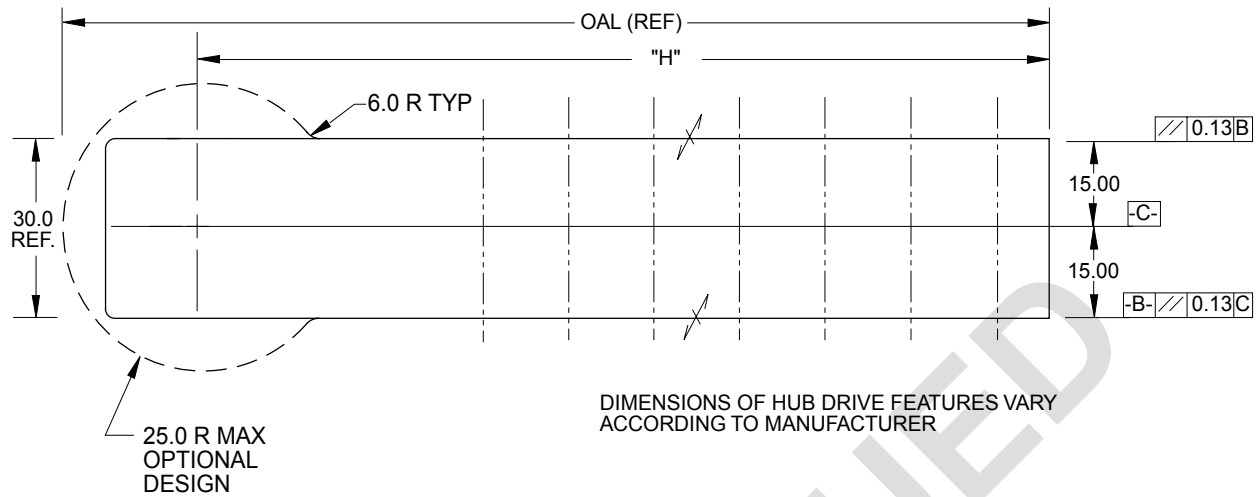

EXCEPT AS NOTED TOLERANCES SHALL BE:

- 1 PLACE MACHINING  $\pm 0.3$
- 1 PLACE FABRICATION  $\pm 1.5$
- 2 PLACE  $\pm 0.03$  GENERAL
- $\pm 0.03$  BETWEEN DOWELS
- $\pm 0.13$  TO SCREW HOLES

STAMP OR ETCH THE NAAMS CODE NUMBER AND THE CLAMP ARM MANUFACTURER'S NUMBER, IF DIFFERENT, ON THE SIDE OF THE ARM.

NOTES: ALL DIMENSIONS METRIC UNLESS OTHERWISE NOTED.

MATERIAL: SAE 4140 or SAE 1045

PAINT AS PRESCRIBED ON PAGE G-1.2

NAAMS CODE	DIM. "A"	DIM. "B"	DIM. "C"	DIM. "D"	DIM. "E"	DIM. "F"	DIM. "G"	DIM. "H" +1.5/-0.0	MAX OAL (REF)	WEIGHT kg
ACA206M	80.00	65.00	50.00					90.0	115.0	0.4
ACA207M	110.00	95.00	80.00	65.00	50.00			120.0	145.0	0.5
ACA208M	140.00	125.00	110.00	95.00	80.00	65.00	50.00	150.0	175.0	0.6



I  
D  
J  
A  
G  
F  
B  
H  
C  
E



# POWER CLAMP ARMS 50 SERIES

(25mm OFFSET) (MACHINED - FULL METRIC)

GLOBAL STANDARD COMPONENTS



Assembly

11/10/10

H

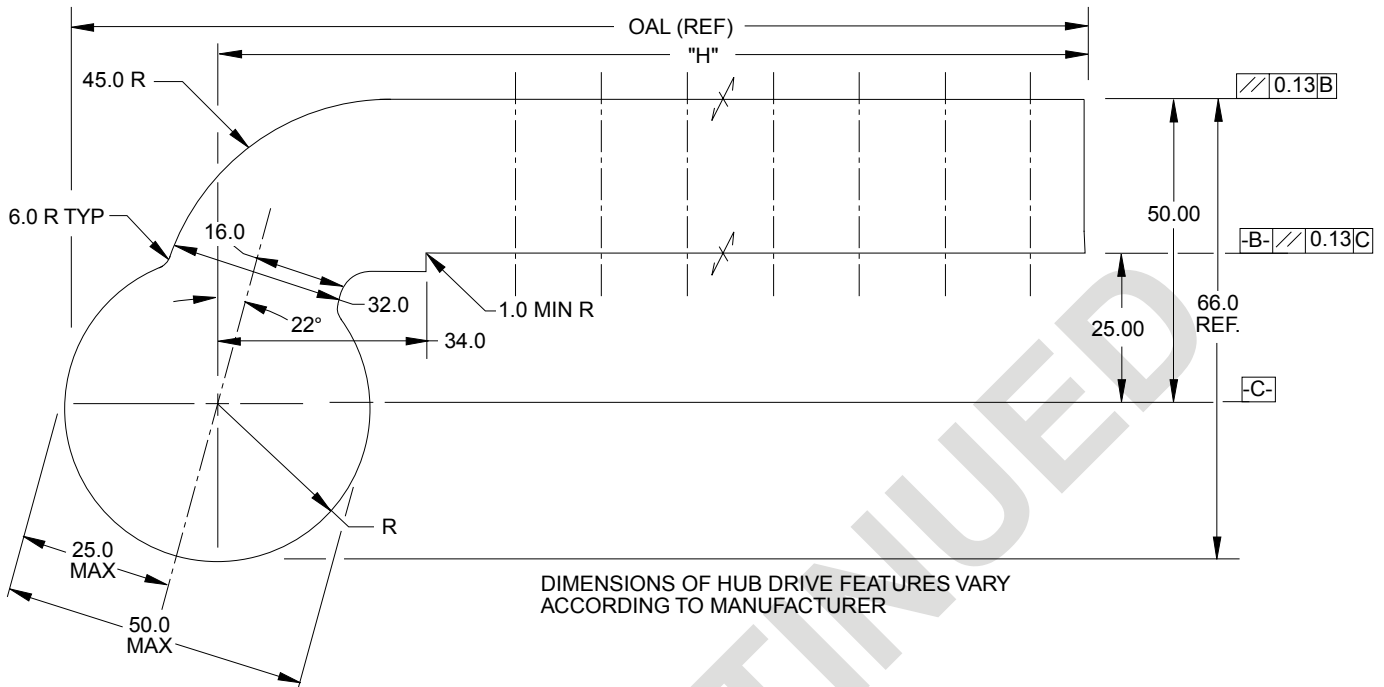

D

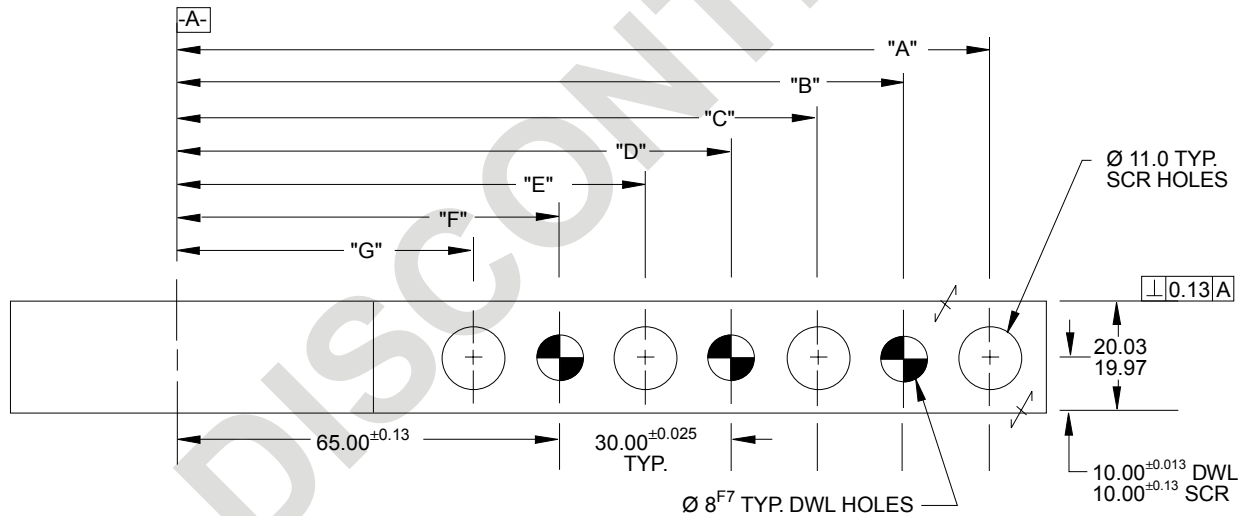

EXCEPT AS NOTED TOLERANCES SHALL BE:

- 1 PLACE MACHINING  $\pm 0.3$
- 1 PLACE FABRICATION  $\pm 1.5$
- 2 PLACE  $\pm 0.03$  GENERAL
- $\pm 0.03$  BETWEEN DOWELS
- $\pm 0.13$  TO SCREW HOLES

STAMP OR ETCH THE NAAMS CODE NUMBER AND THE CLAMP ARM MANUFACTURER'S NUMBER, IF DIFFERENT, ON THE SIDE OF THE ARM.

NOTES: ALL DIMENSIONS METRIC UNLESS OTHERWISE NOTED.

PAIN T AS PRESCRIBED ON PAGE G-1.2

MATERIAL: SAE 4140 or SAE 1045

NAAMS CODE	DIM. "A"	DIM. "B"	DIM. "C"	DIM. "D"	DIM. "E"	DIM. "F"	DIM. "G"	DIM. "H" +1.5/-0.0	MAX OAL (REF)	WEIGHT kg
ACA216M	80.00	65.00	50.00					90.0	115.0	0.5
ACA217M	110.00	95.00	80.00	65.00	50.00			120.0	145.0	0.6
ACA218M	140.00	125.00	110.00	95.00	80.00	65.00	50.00	150.0	175.0	0.7

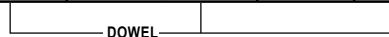

I

A

F

B

G

C

E

# POWER CLAMP ARMS 50 SERIES

(50mm OFFSET) (MACHINED - FULL METRIC)

GLOBAL STANDARD COMPONENTS



Assembly

11/10/10

E

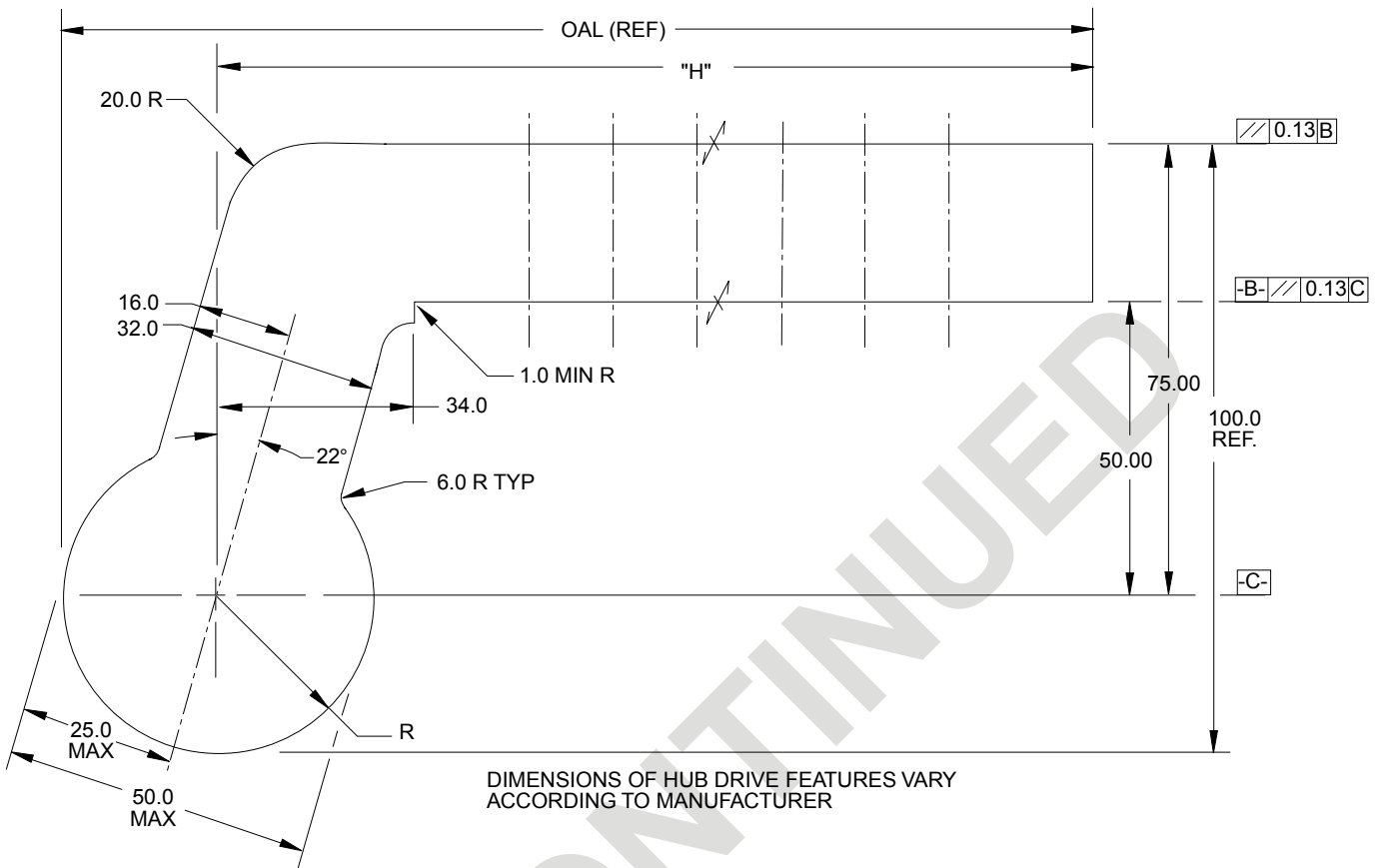

C

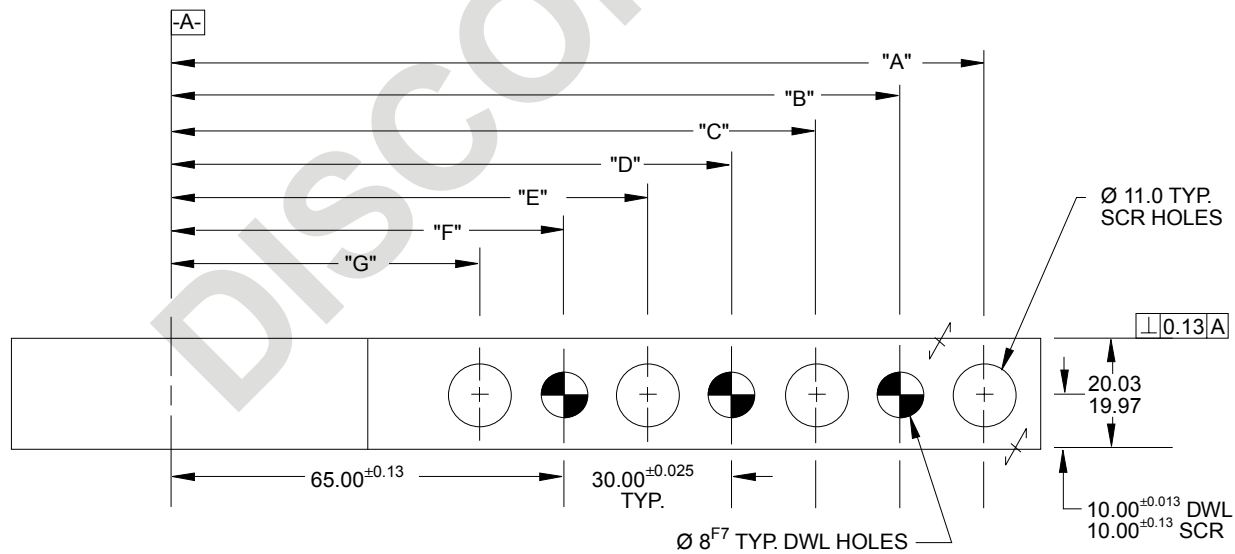

F

A

STAMP OR ETCH THE NAAMS CODE NUMBER AND THE CLAMP ARM MANUFACTURER'S NUMBER, IF DIFFERENT, ON THE SIDE OF THE ARM.

PAINT AS PRESCRIBED ON PAGE G-1.2

TABULATED INFORMATION ON FOLLOWING PAGE

D

B

# POWER CLAMP ARMS 50 SERIES

(50mm OFFSET) (MACHINED - FULL METRIC)

GLOBAL STANDARD COMPONENTS



Assembly

11/10/10

D

EXCEPT AS NOTED TOLERANCES SHALL BE:

- 1 PLACE MACHINING  $\pm 0.3$
- 1 PLACE FABRICATION  $\pm 1.5$
- 2 PLACE  $\pm 0.03$  GENERAL
- $\pm 0.03$  BETWEEN DOWELS
- $\pm 0.13$  TO SCREW HOLES

NOTES: ALL DIMENSIONS METRIC UNLESS OTHERWISE NOTED.

MATERIAL: SAE 4140 or SAE 1045

C

B

A

NAAMS CODE	DIM. "A"	DIM. "B"	DIM. "C"	DIM. "D"	DIM. "E"	DIM. "F"	DIM. "G"	DIM. "H" +1.5/-0.0	MAX OAL (REF)	WEIGHT kg
ACA226M	80.00	65.00	50.00					90.0	115.0	0.6
ACA227M	110.00	95.00	80.00	65.00	50.00			120.0	145.0	0.7
ACA228M	140.00	125.00	110.00	95.00	80.00	65.00	50.00	150.0	175.0	0.8



SEE DRAWING ON PREVIOUS PAGE

DISCONTINUED

# POWER CLAMP ARMS 50 SERIES

(STRAIGHT - MACHINED) (FULL METRIC)

GLOBAL STANDARD COMPONENTS



Assembly

09/05/12

D

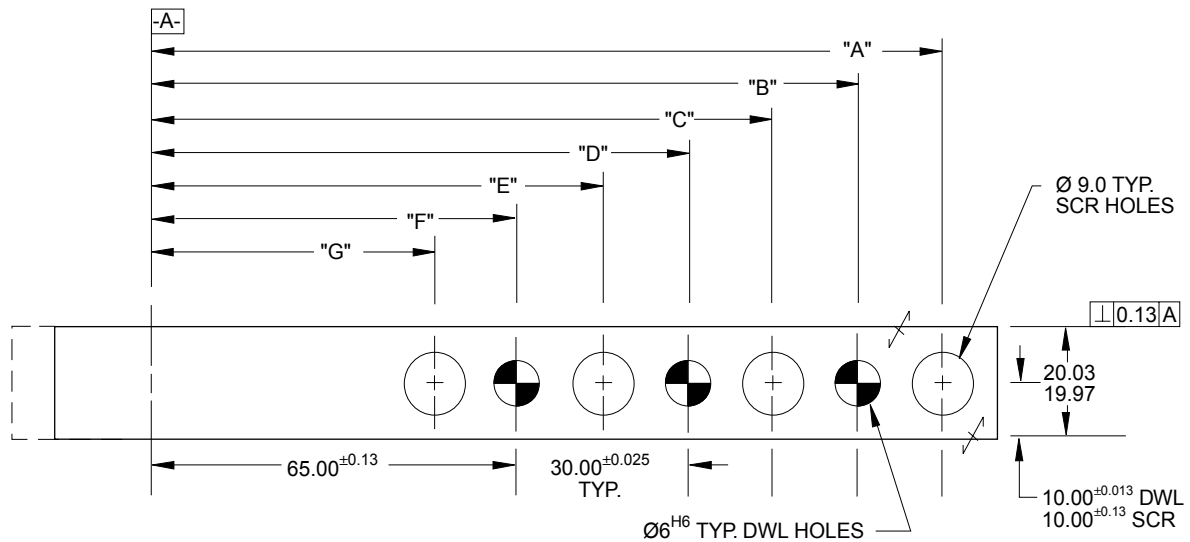
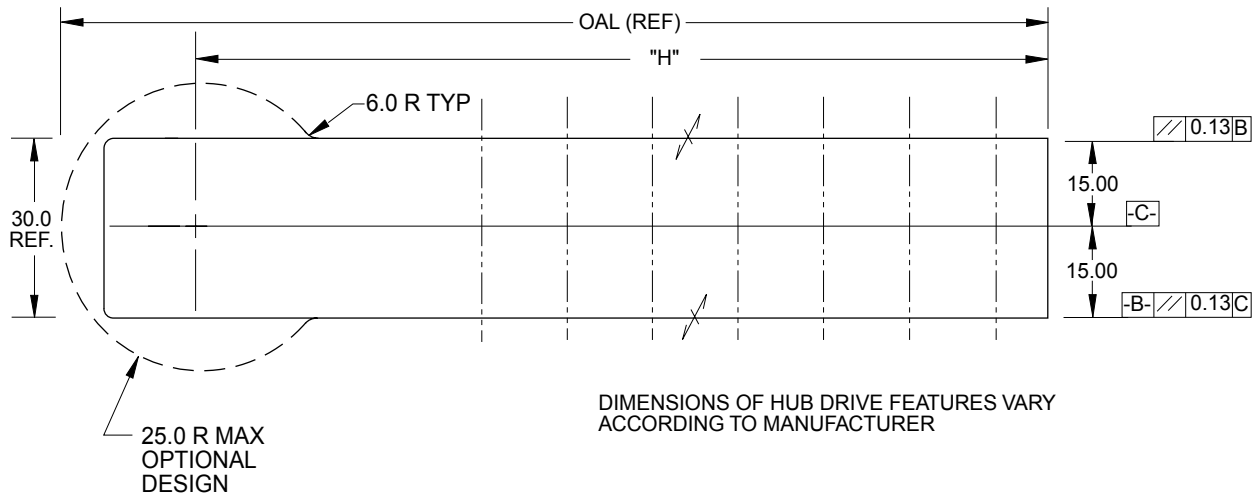

EXCEPT AS NOTED TOLERANCES SHALL BE:

- 1 PLACE MACHINING  $\pm 0.3$
- 1 PLACE FABRICATION  $\pm 1.5$
- 2 PLACE  $\pm 0.03$  GENERAL
- $\pm 0.03$  BETWEEN DOWELS
- $\pm 0.13$  TO SCREW HOLES

NOTES: ALL DIMENSIONS METRIC UNLESS OTHERWISE NOTED.

MATERIAL: SAE 4140 or SAE 1045

STAMP OR ETCH THE NAAMS CODE NUMBER AND THE CLAMP ARM MANUFACTURER'S NUMBER, IF DIFFERENT, ON THE SIDE OF THE ARM.

PAINT AS PRESCRIBED ON PAGE G-1.2

NAAMS CODE	DIM. "A"	DIM. "B"	DIM. "C"	DIM. "D"	DIM. "E"	DIM. "F"	DIM. "G"	DIM. "H" +1.5/-0.0	MAX OAL (REF)	WEIGHT kg
ACA236M	80.00	65.00	50.00					90.0	115.0	0.4
ACA237M	110.00	95.00	80.00	65.00	50.00			120.0	145.0	0.5
ACA238M	140.00	125.00	110.00	95.00	80.00	65.00	50.00	150.0	175.0	0.6



E

B

F

A

C

# POWER CLAMP ARMS 50 SERIES

(25mm OFFSET - MACHINED) (FULL METRIC)

GLOBAL STANDARD COMPONENTS



Assembly

09/05/12

C

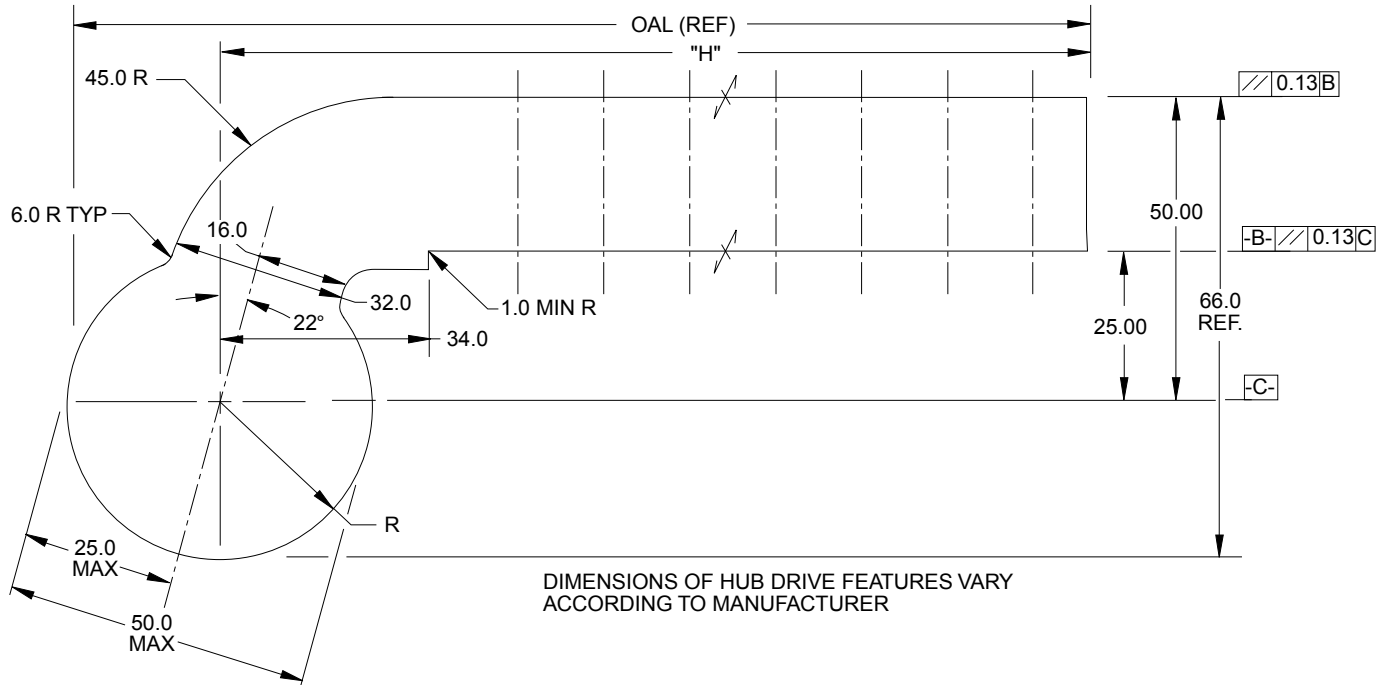

DIMENSIONS OF HUB DRIVE FEATURES VARY ACCORDING TO MANUFACTURER

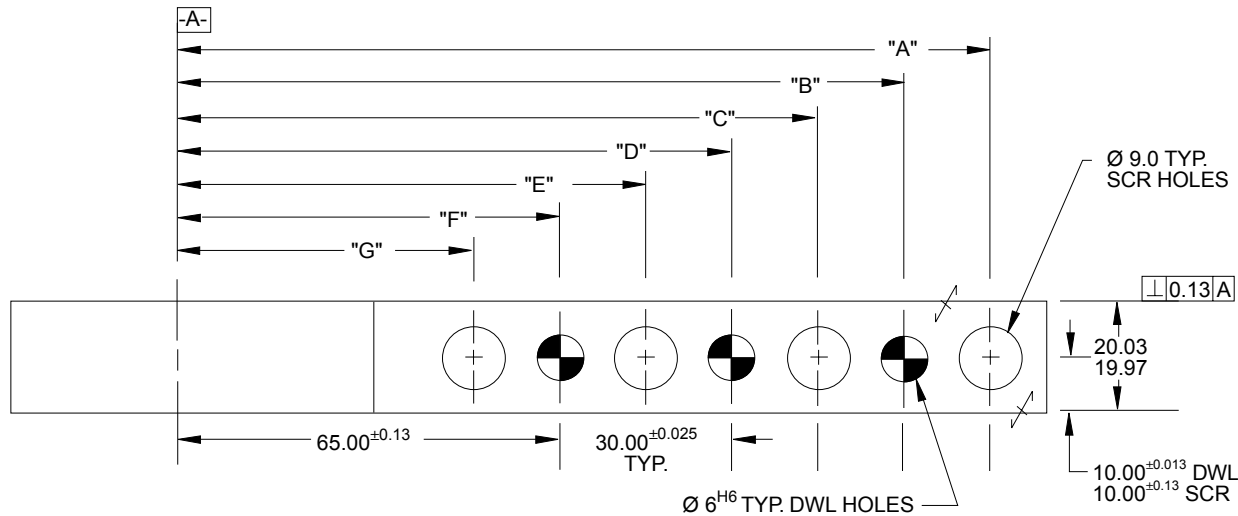

EXCEPT AS NOTED TOLERANCES SHALL BE:

- 1 PLACE MACHINING  $\pm 0.3$
- 1 PLACE FABRICATION  $\pm 1.5$
- 2 PLACE  $\pm 0.03$  GENERAL
- $\pm 0.03$  BETWEEN DOWELS
- $\pm 0.13$  TO SCREW HOLES

STAMP OR ETCH THE NAAMS CODE NUMBER AND THE CLAMP ARM MANUFACTURER'S NUMBER, IF DIFFERENT, ON THE SIDE OF THE ARM.

NOTES: ALL DIMENSIONS METRIC UNLESS OTHERWISE NOTED.  
MATERIAL: SAE 4140 or SAE 1045

PAIN T AS PRESCRIBED ON PAGE G-1.2

NAAMS CODE	DIM. "A"	DIM. "B"	DIM. "C"	DIM. "D"	DIM. "E"	DIM. "F"	DIM. "G"	DIM. "H" +1.5/-0.0	MAX OAL (REF)	WEIGHT kg
ACA246M	80.00	65.00	50.00					90.0	115.0	0.5
ACA247M	110.00	95.00	80.00	65.00	50.00			120.0	145.0	0.6
ACA248M	140.00	125.00	110.00	95.00	80.00	65.00	50.00	150.0	175.0	0.7



D

E

A

B

# POWER CLAMP ARMS 50 SERIES

(50mm OFFSET - MACHINED) (FULL METRIC)

GLOBAL STANDARD COMPONENTS



Assembly

09/05/12

B

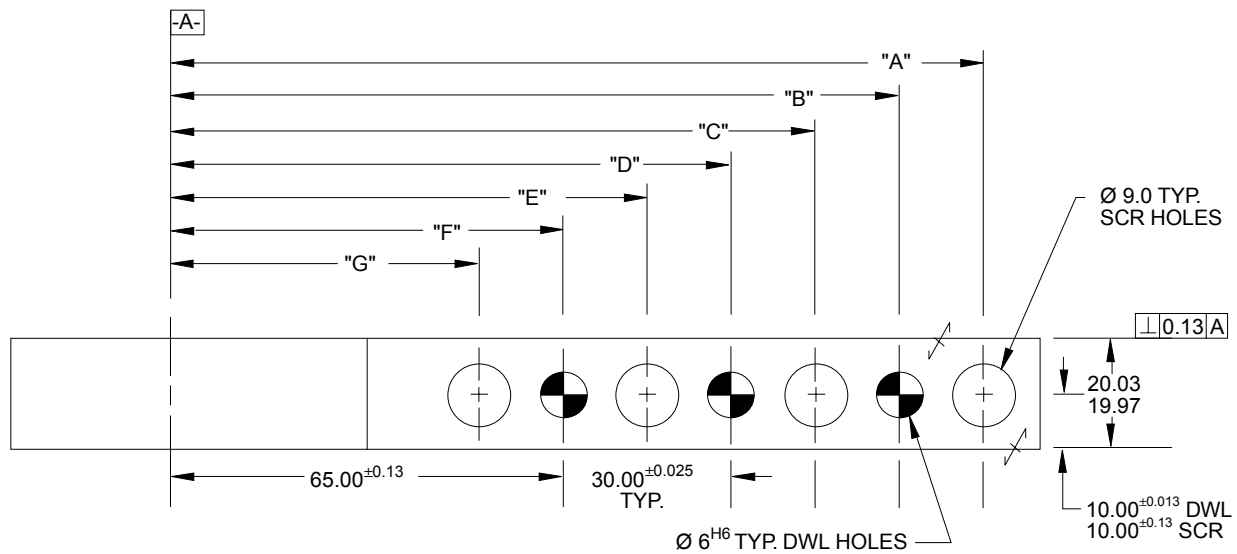
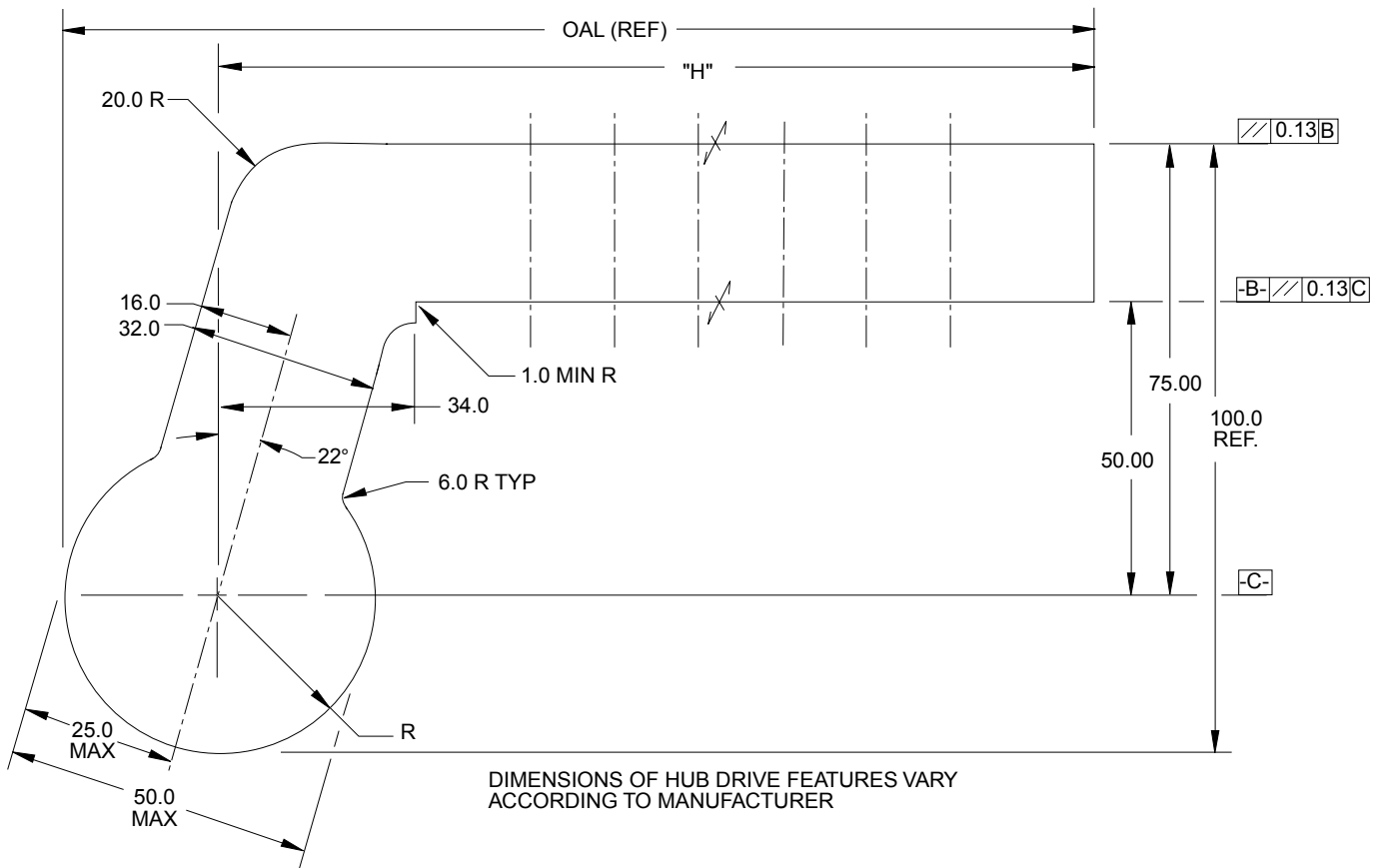

STAMP OR ETCH THE NAAMS CODE NUMBER AND THE CLAMP ARM MANUFACTURER'S NUMBER, IF DIFFERENT, ON THE SIDE OF THE ARM.

PAINT AS PRESCRIBED ON PAGE G-1.2

TABULATED INFORMATION ON FOLLOWING PAGE

C

B

A

# POWER CLAMP ARMS 50 SERIES

(50mm OFFSET - MACHINED) (FULL METRIC)

GLOBAL STANDARD COMPONENTS



Assembly

11/10/10

B

EXCEPT AS NOTED TOLERANCES SHALL BE:

- 1 PLACE MACHINING  $\pm 0.3$
- 1 PLACE FABRICATION  $\pm 1.5$
- 2 PLACE  $\pm 0.03$  GENERAL
  - $\pm 0.03$  BETWEEN DOWELS
  - $\pm 0.13$  TO SCREW HOLES

NOTES: ALL DIMENSIONS METRIC UNLESS OTHERWISE NOTED.

MATERIAL: SAE 4140 or SAE 1045

A

NAAMS CODE	DIM. "A"	DIM. "B"	DIM. "C"	DIM. "D"	DIM. "E"	DIM. "F"	DIM. "G"	DIM. "H" +1.5/-0.0	MAX OAL (REF)	WEIGHT kg
ACA256M	80.00	65.00	50.00					90.0	115.0	0.6
ACA257M	110.00	95.00	80.00	65.00	50.00			120.0	145.0	0.7
ACA258M	140.00	125.00	110.00	95.00	80.00	65.00	50.00	150.0	175.0	0.8

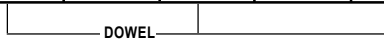

SEE DRAWING ON PREVIOUS PAGE

# 60 SERIES POWER CLAMP ENVELOPE

C

EXCEPT AS NOTED 2 PLACE TOLERANCES SHALL BE:

- ±0.03 GENERAL
- ±0.03 BETWEEN DOWEL HOLES
- ±0.13 BETWEEN SCREW HOLES

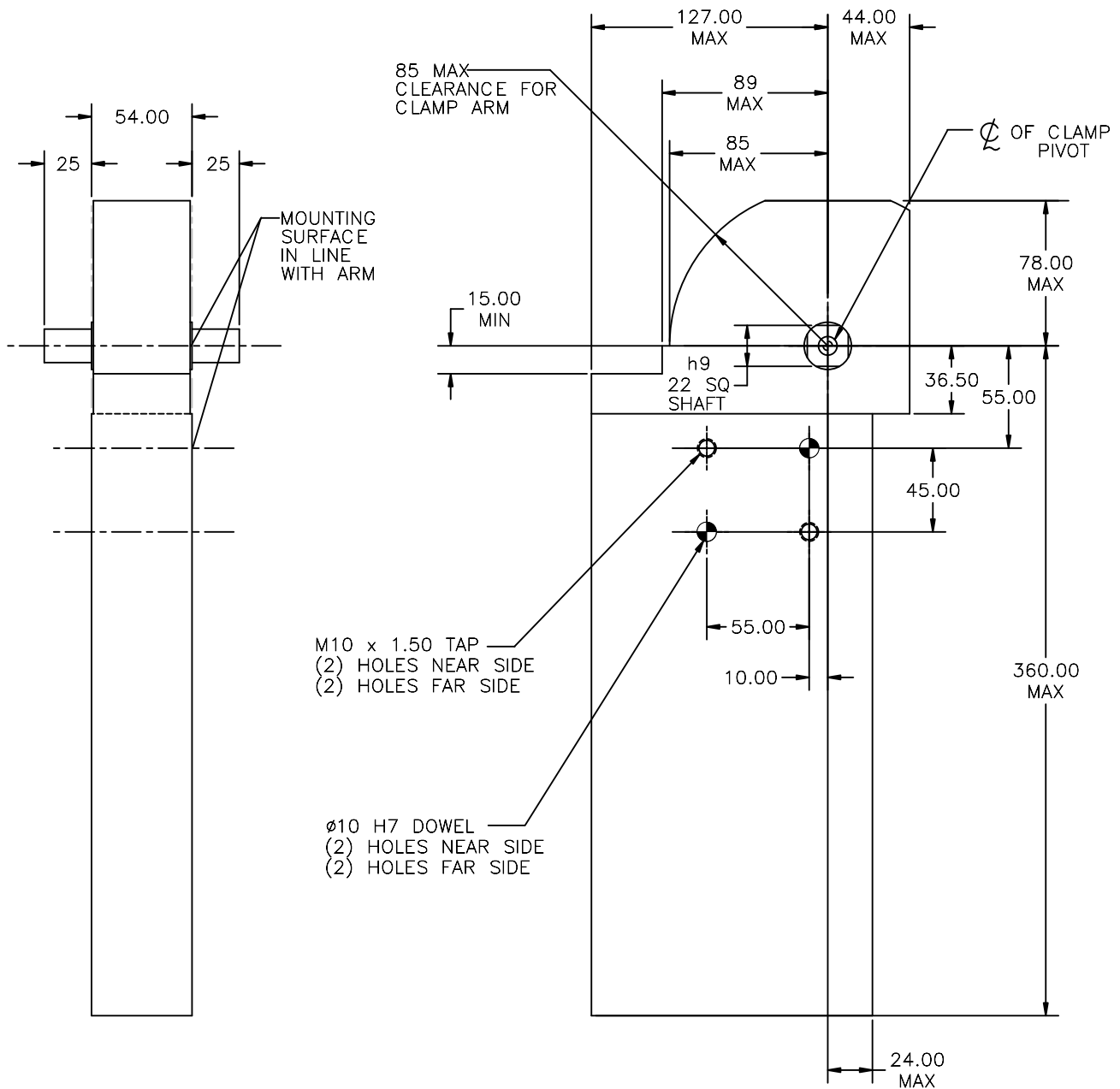

B

THIS STANDARD BECOMES EFFECTIVE OCTOBER 1ST 2007

A



# 60 SERIES POWER CLAMP OPTIONAL MOUNTING

C

OPTIONAL FRONT "AND OR"  
 REAR MOUNTING

EXCEPT AS NOTED 2 PLACE TOLERANCES  
 SHALL BE:

- ±0.03 GENERAL
- ±0.03 BETWEEN DOWEL HOLES
- ±0.13 BETWEEN SCREW HOLES

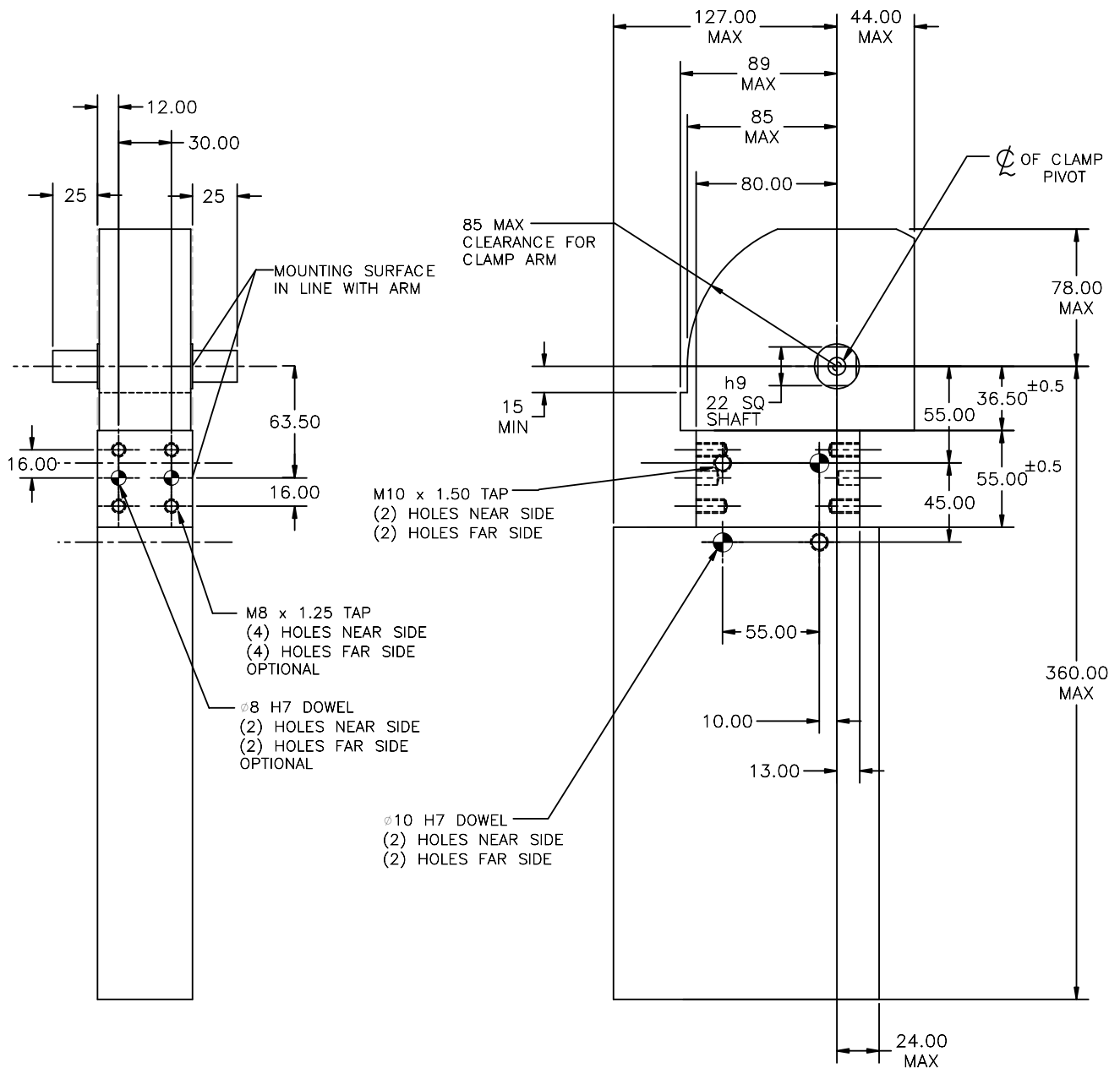

B

THIS STANDARD BECOMES EFFECTIVE SEPTEMBER 1ST 2007

A

# 50 SERIES POWER CLAMP ENVELOPE

GLOBAL STANDARD COMPONENTS



Assembly

11/10/10

C

EXCEPT AS NOTED METRIC TOLERANCES SHALL BE:

- 2 PLACE  $\pm 0.03$  GENERAL
- $\pm 0.03$  BETWEEN DOWELS
- $\pm 0.13$  TP SCREW HOLES

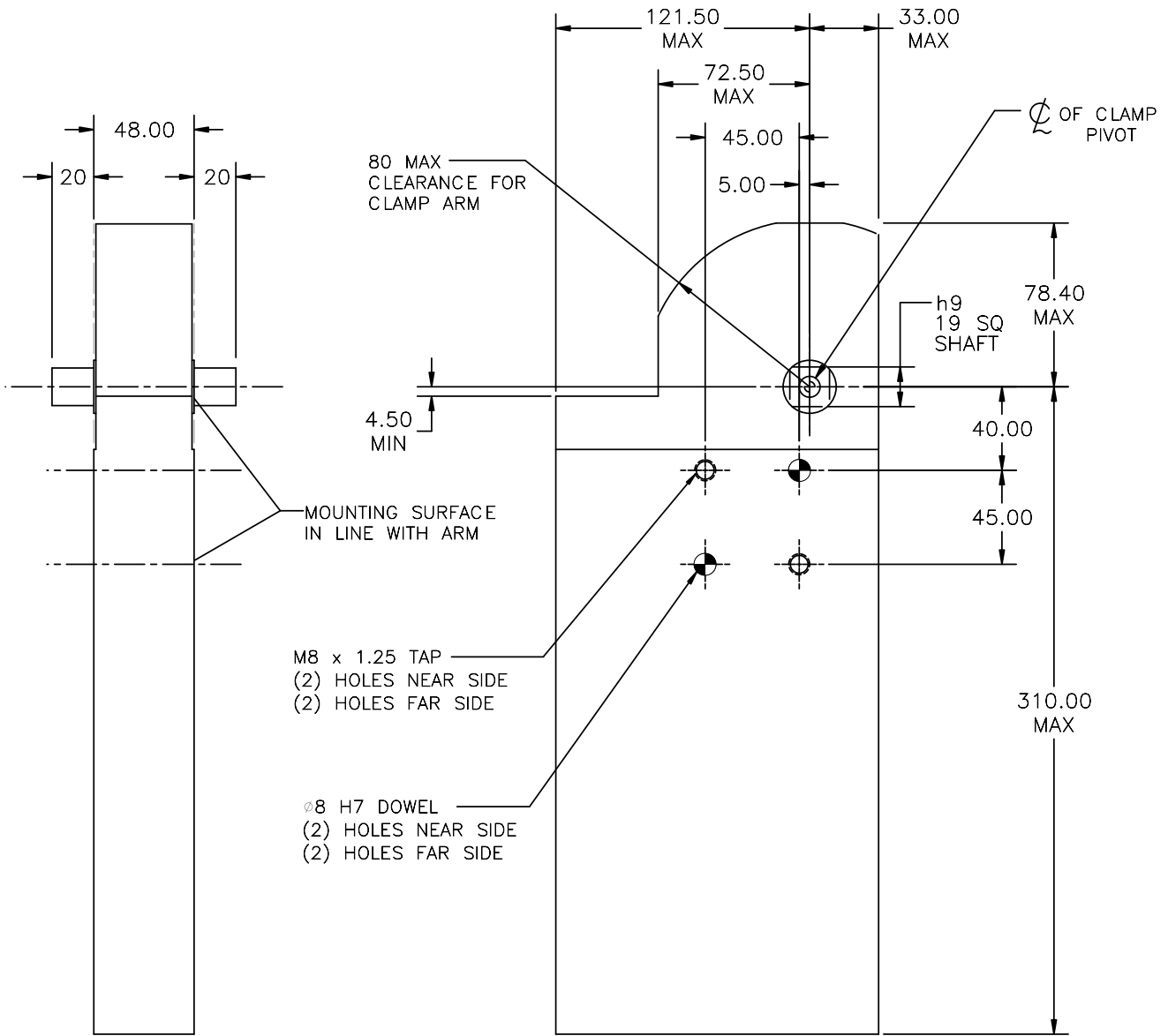

B

THIS STANDARD BECOMES EFFECTIVE SEPTEMBER 1ST 2007

A

# 50 SERIES POWER CLAMP OPTIONAL MOUNTING

GLOBAL STANDARD COMPONENTS



Assembly

11/10/10

C

OPTIONAL FRONT "AND OR"  
REAR MOUNTING

EXCEPT AS NOTED METRIC TOLERANCES  
SHALL BE:

- 2 PLACE  $\pm 0.03$  GENERAL
- $\pm 0.03$  BETWEEN DOWELS
- $\pm 0.13$  TP SCREW HOLES

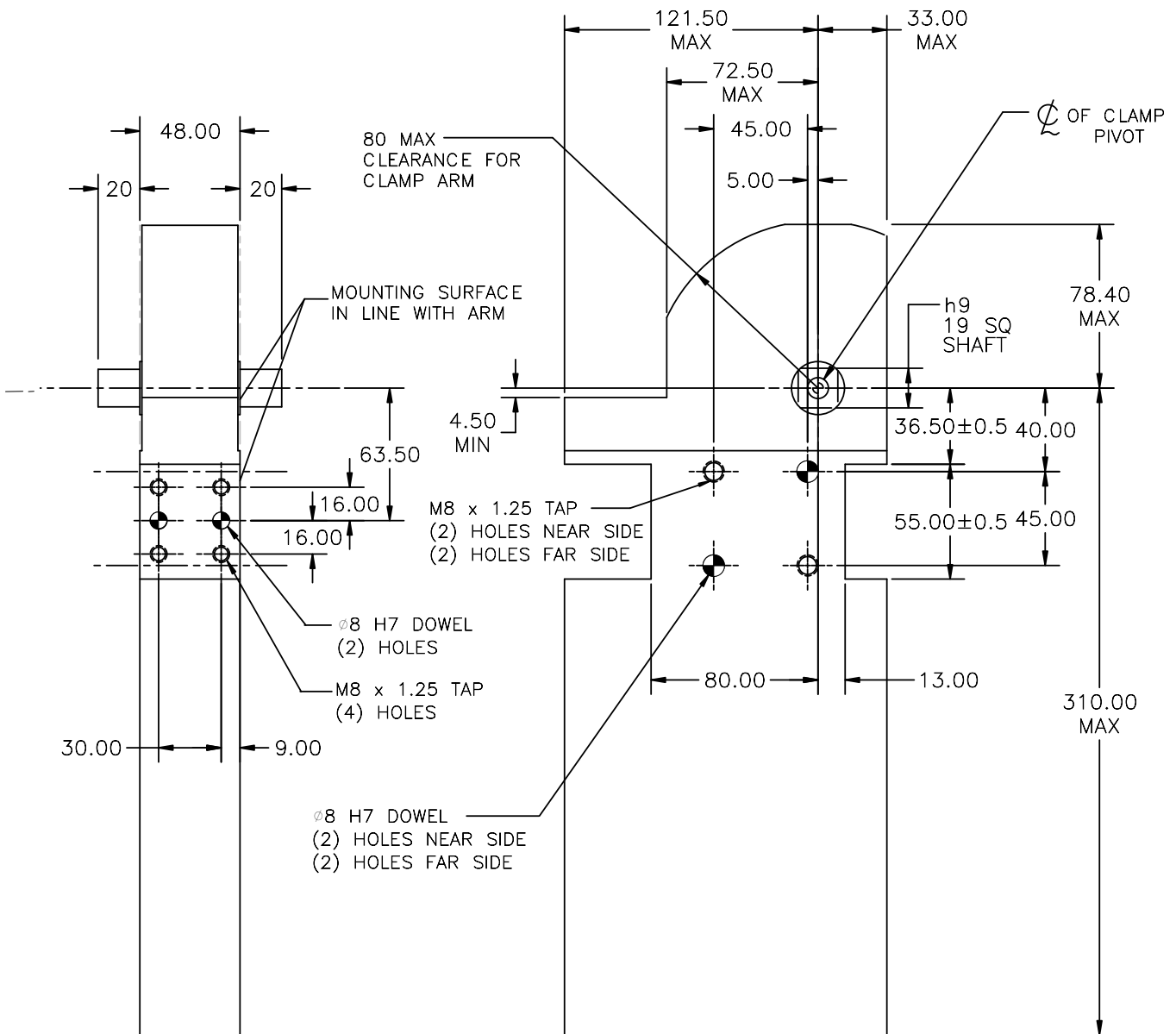

B

THIS STANDARD BECOMES EFFECTIVE SEPTEMBER 1ST 2007

A

# 80/90 SERIES POWER CLAMP ENVELOPE

A

EXCEPT AS NOTED METRIC TOLERANCES SHALL BE:  
 2 PLACE  $\pm 0.03$  GENERAL  
 $\pm 0.03$  BETWEEN DOWELS  
 $\pm 0.13$  TP SCREW HOLES

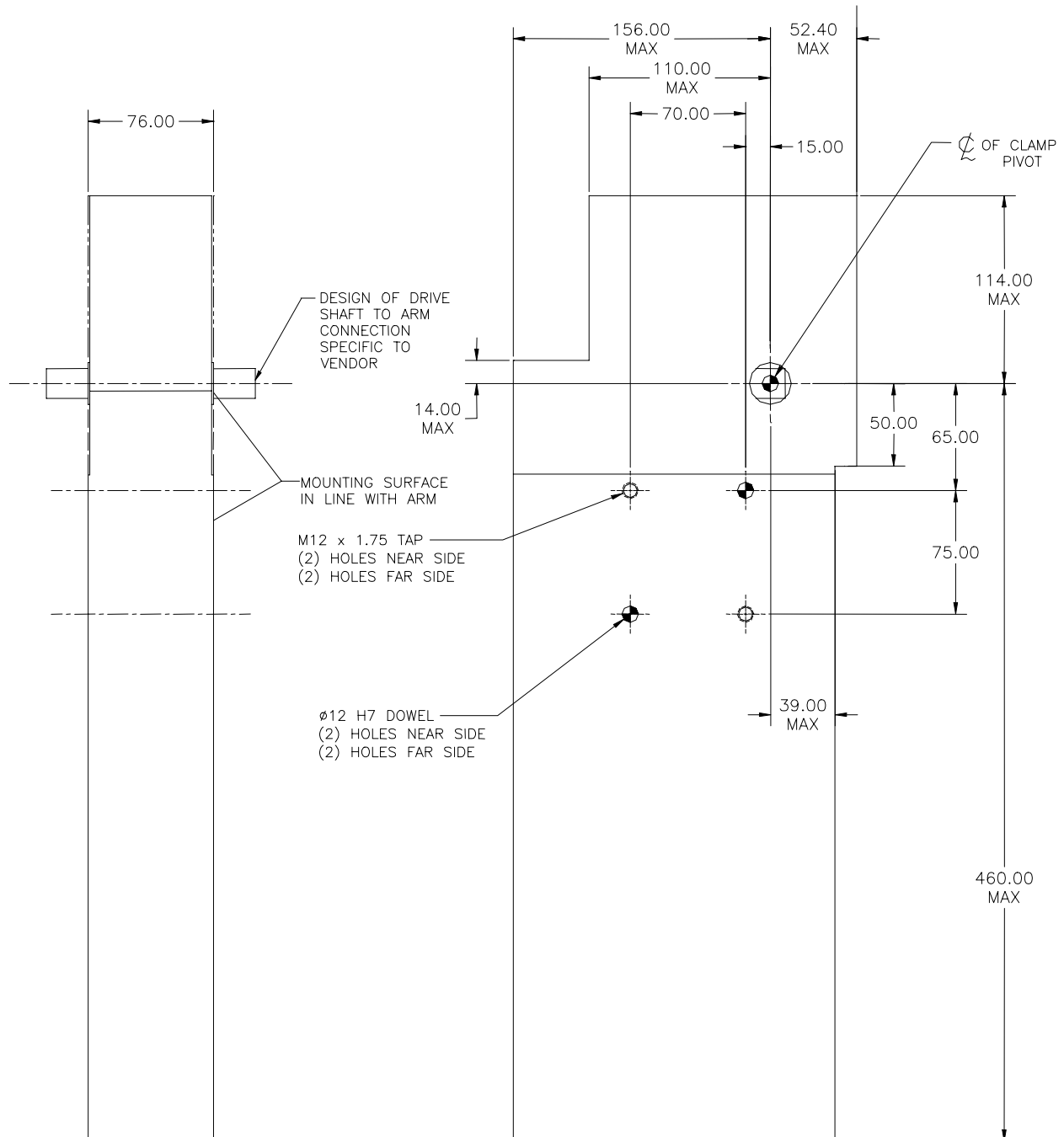

THIS STANDARD BECOMES EFFECTIVE JULY 22ND 2006

# 80/90 SERIES POWER CLAMP OPTIONAL MOUNTING

GLOBAL STANDARD COMPONENTS



Assembly

11/10/10

A

EXCEPT AS NOTED METRIC TOLERANCES  
SHALL BE:

- 2 PLACE  $\pm 0.03$  GENERAL
- $\pm 0.03$  BETWEEN DOWELS
- $\pm 0.13$  TP SCREW HOLES

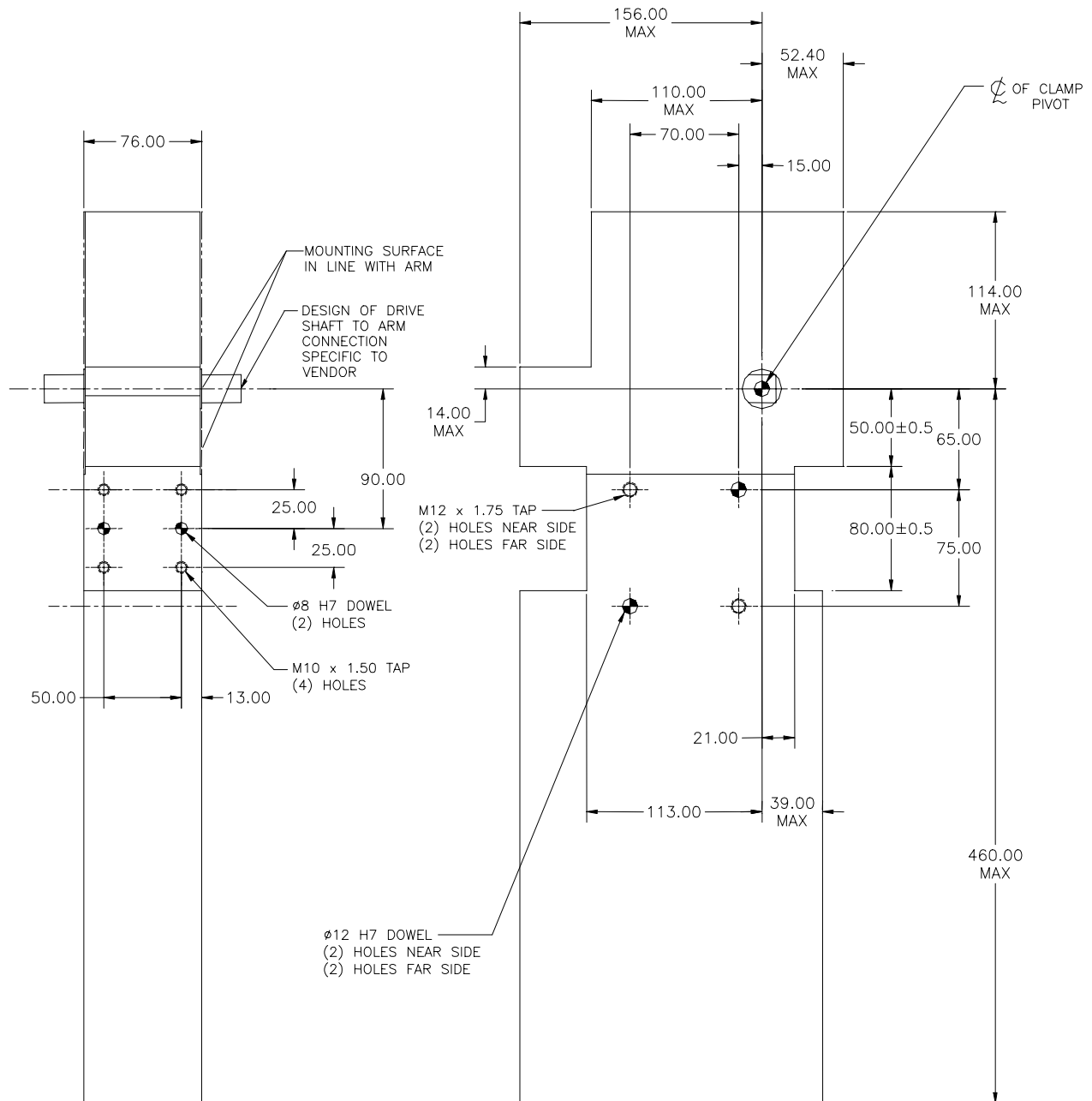

THIS STANDARD BECOMES EFFECTIVE JULY 22ND 2006

# WISHBONE CLAMP ARMS 50 SERIES 25mm OFFSET

GLOBAL STANDARD COMPONENTS



Assembly

09/05/12

A

B

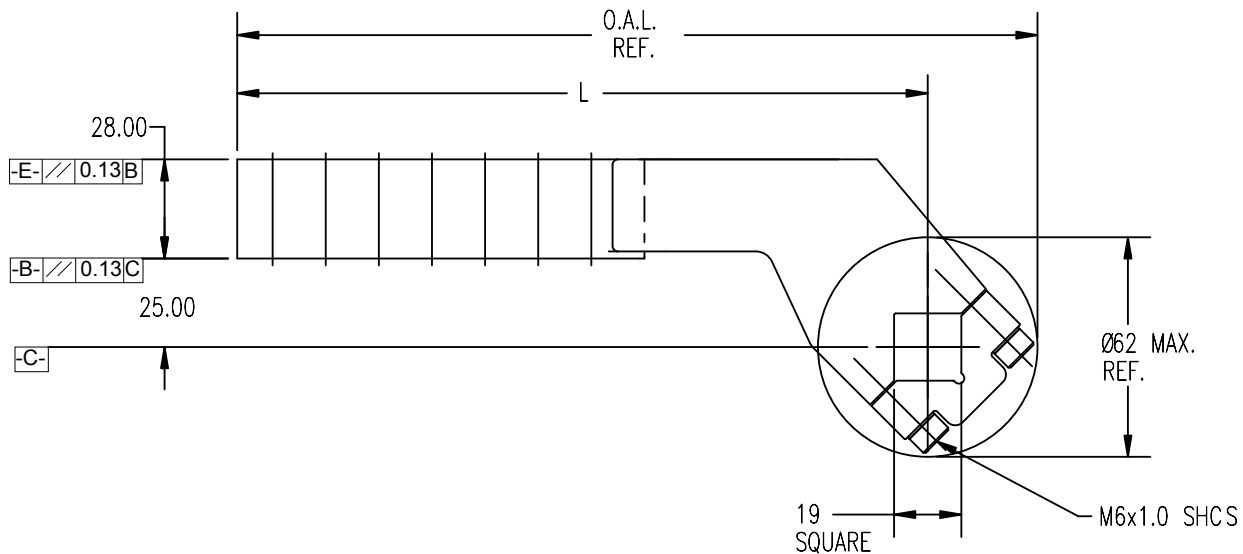
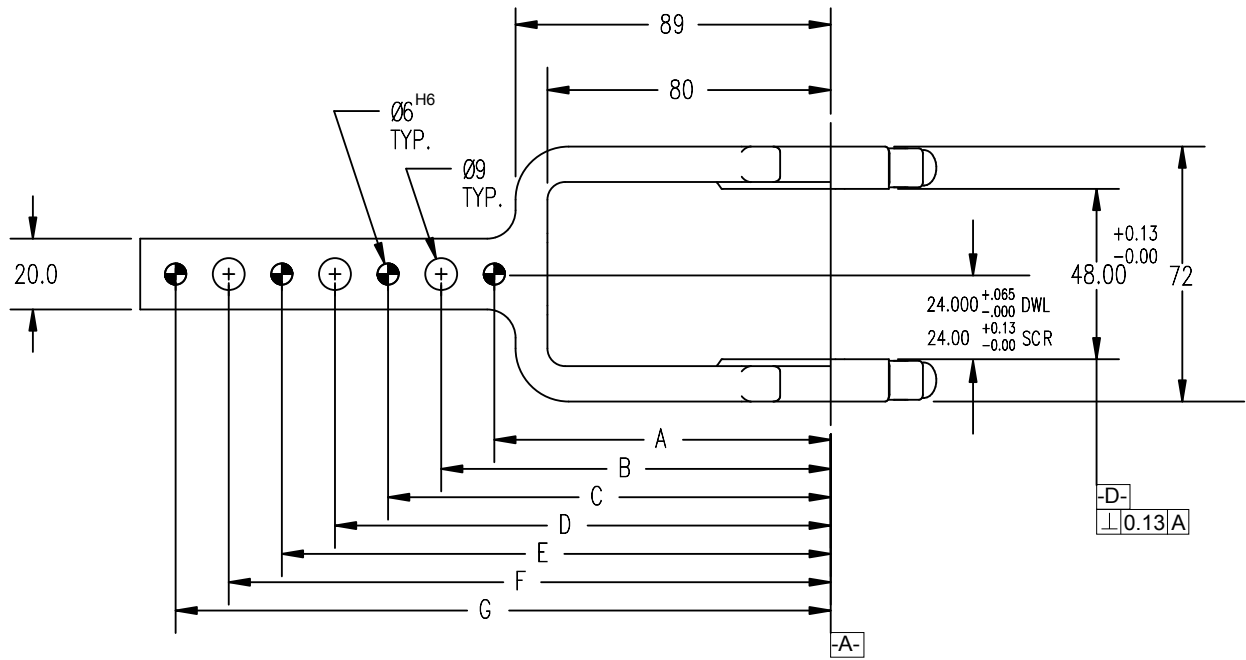

EXCEPT AS NOTED TOLERANCES SHALL BE:

- 1 PLACE MACHINING  $\pm 0.3$
- 1 PLACE FABRICATION  $\pm 1.5$
- 2 PLACE  $\pm 0.03$  GENERAL
- $\pm 0.03$  BETWEEN DOWELS
- $\pm 0.13$  TO SCREW HOLES

NOTES: ALL DIMENSIONS METRIC UNLESS OTHERWISE NOTED.  
MATERIAL: SAE 4140 or SAE 1045

STAMP OR ETCH THE NAAMS CODE NUMBER AND THE CLAMP ARM MANUFACTURER'S NUMBER, IF DIFFERENT, ON THE SIDE OF THE ARM.

PAINT AS PRESCRIBED ON PAGE G-1.2

THIS STANDARD BECOMES EFFECTIVE SEPTEMBER 1ST 2007

TABULATED INFORMATION ON FOLLOWING PAGE

# WISHBONE CLAMP ARMS 50 SERIES 25mm OFFSET

GLOBAL STANDARD COMPONENTS



Assembly

11/10/10

A

EXCEPT AS NOTED TOLERANCES SHALL BE:

- 1 PLACE MACHINING  $\pm 0.3$
- 1 PLACE FABRICATION  $\pm 1.5$
- 2 PLACE  $\pm 0.03$  GENERAL
  - $\pm 0.03$  BETWEEN DOWELS
  - $\pm 0.13$  TO SCREW HOLES

NOTES: ALL DIMENSIONS METRIC UNLESS OTHERWISE NOTED.

MATERIAL: SAE 4140 or SAE 1045

ARM NO.	A DWL	B	C DWL	D	E DWL	F	G DWL	L	O.A.L.	WEIGHT Kg [Lbs]
ACA301M	95	110	125	-	-	-	-	135	166	0.9 [2.0]
ACA302M	95	110	125	140	155	-	-	165	196	1.0 [2.2]
ACA303M	95	110	125	140	155	170	185	195	226	1.2 [2.6]

SEE DRAWING ON PREVIOUS PAGE

THIS STANDARD BECOMES EFFECTIVE SEPTEMBER 1ST 2007

# WISHBONE CLAMP ARMS 50 SERIES 50mm OFFSET

A  
B

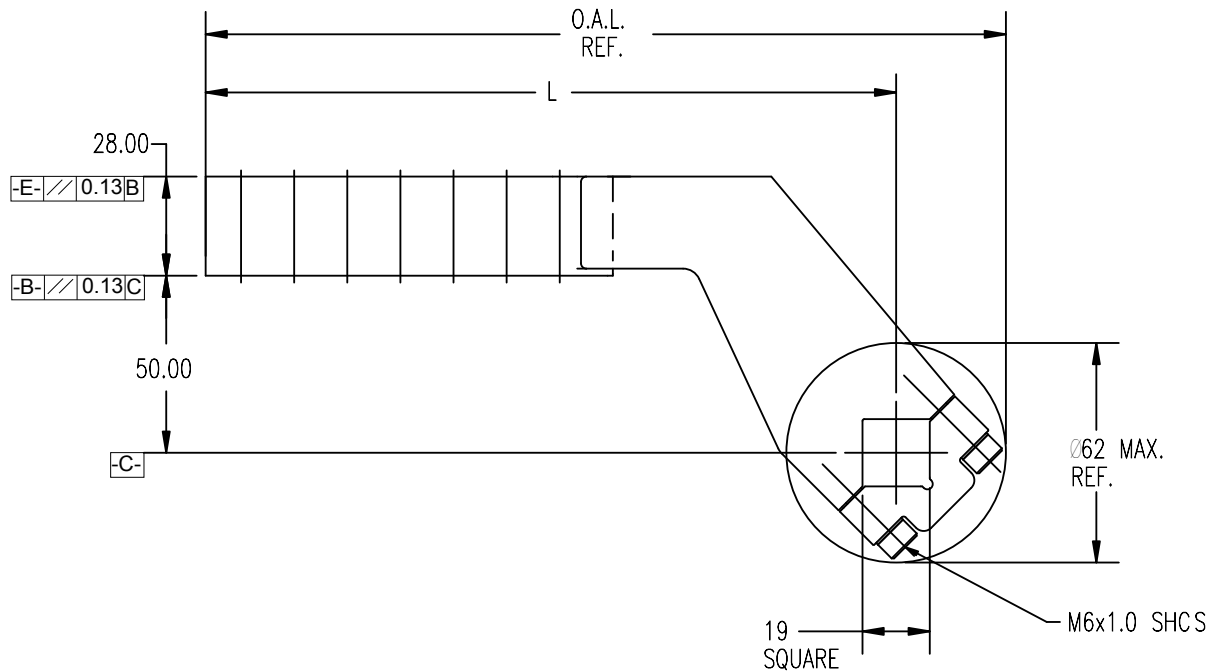
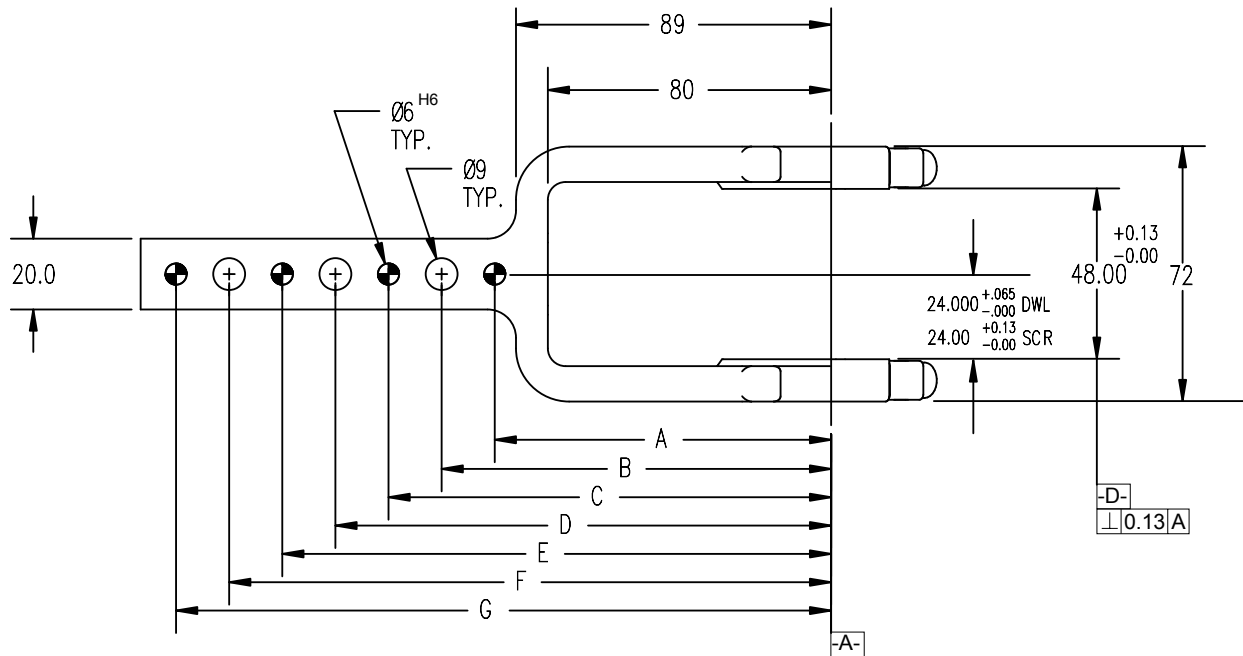

EXCEPT AS NOTED TOLERANCES SHALL BE:

- 1 PLACE MACHINING  $\pm 0.3$
- 1 PLACE FABRICATION  $\pm 1.5$
- 2 PLACE  $\pm 0.03$  GENERAL
- $\pm 0.03$  BETWEEN DOWELS
- $\pm 0.13$  TO SCREW HOLES

NOTES: ALL DIMENSIONS METRIC UNLESS OTHERWISE NOTED.  
 MATERIAL: SAE 4140 or SAE 1045

STAMP OR ETCH THE NAAMS CODE NUMBER AND THE CLAMP ARM MANUFACTURER'S NUMBER, IF DIFFERENT, ON THE SIDE OF THE ARM.

PAINT AS PRESCRIBED ON PAGE G-1.2

THIS STANDARD BECOMES EFFECTIVE SEPTEMBER 1ST 2007

TABULATED INFORMATION ON FOLLOWING PAGE



# WISHBONE CLAMP ARMS 50 SERIES 50mm OFFSET

EXCEPT AS NOTED TOLERANCES SHALL BE:

- 1 PLACE MACHINING  $\pm 0.3$
- 1 PLACE FABRICATION  $\pm 1.5$
- 2 PLACE  $\pm 0.03$  GENERAL
  - $\pm 0.03$  BETWEEN DOWELS
  - $\pm 0.13$  TO SCREW HOLES

NOTES: ALL DIMENSIONS METRIC UNLESS OTHERWISE NOTED.

MATERIAL: SAE 4140 or SAE 1045

ARM NO.	A DWL	B	C DWL	D	E DWL	F	G DWL	L	O.A.L.	WEIGHT Kg [Lbs]
ACA311M	95	110	125	-	-	-	-	135	166	1.1 [2.4]
ACA312M	95	110	125	140	155	-	-	165	196	1.2 [2.7]
ACA313M	95	110	125	140	155	170	185	195	226	1.4 [3.0]

SEE DRAWING ON PREVIOUS PAGE

THIS STANDARD BECOMES EFFECTIVE SEPTEMBER 1ST 2007



# WISHBONE CLAMP ARMS 60 SERIES 25mm OFFSET

GLOBAL STANDARD COMPONENTS



Assembly

11/10/10

A

EXCEPT AS NOTED TOLERANCES SHALL BE:

- 1 PLACE MACHINING  $\pm 0.3$
- 1 PLACE FABRICATION  $\pm 1.5$
- 2 PLACE  $\pm 0.03$  GENERAL
- $\pm 0.03$  BETWEEN DOWELS
- $\pm 0.13$  TO SCREW HOLES

NOTES: ALL DIMENSIONS METRIC UNLESS OTHERWISE NOTED.

MATERIAL: SAE 4140 or SAE 1045

ARM NO.	A DWL	B	C DWL	D	E DWL	F	G DWL	J	K DWL	M	N DWL	P	Q DWL	L	O.A.L.	WEIGHT Kg [Lbs]
ACA320M	95	110	125	-	-	-	-	-	-	-	-	-	-	135	170	1.3 [2.8]
ACA321M	95	110	125	140	155	-	-	-	-	-	-	-	-	165	200	1.4 [3.1]
ACA322M	95	110	125	140	155	170	185	-	-	-	-	-	-	195	230	1.5 [3.3]
ACA323M	95	110	125	140	155	170	185	200	215	-	-	-	-	225	260	1.6 [3.6]
ACA324M	95	110	125	140	155	170	185	200	215	230	245	-	-	255	290	1.7 [3.8]
ACA325M	95	110	125	140	155	170	185	200	215	230	245	260	275	285	320	1.8 [4.0]

SEE DRAWING ON PREVIOUS PAGE

THIS STANDARD BECOMES EFFECTIVE SEPTEMBER 1ST 2007

# WISHBONE CLAMP ARMS 60 SERIES 70mm OFFSET

GLOBAL STANDARD COMPONENTS



Assembly

09/05/12

A

B

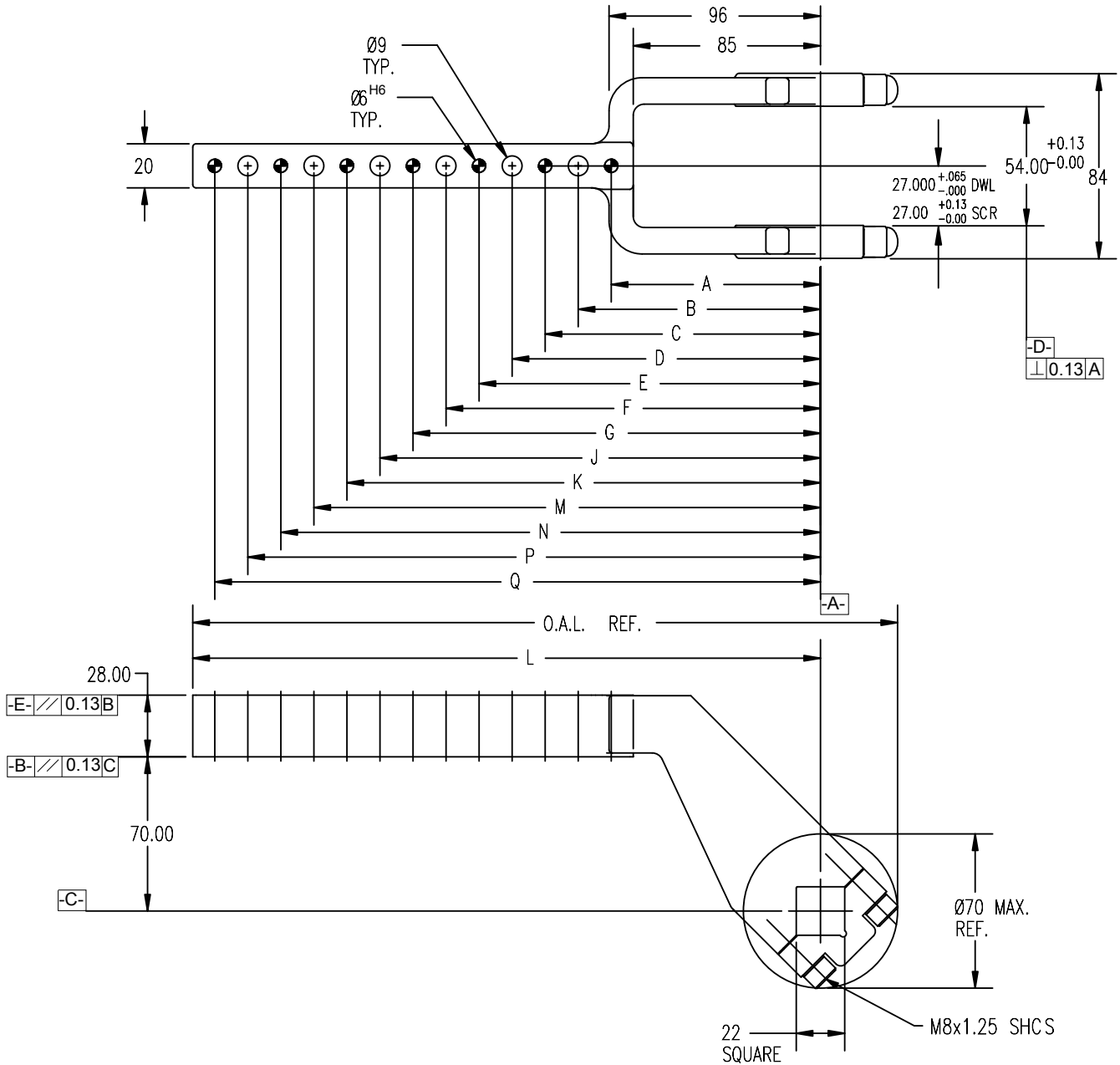

EXCEPT AS NOTED TOLERANCES SHALL BE:

- 1 PLACE MACHINING  $\pm 0.3$
- 1 PLACE FABRICATION  $\pm 1.5$
- 2 PLACE  $\pm 0.03$  GENERAL
- $\pm 0.03$  BETWEEN DOWELS
- $\pm 0.13$  TO SCREW HOLES

NOTES: ALL DIMENSIONS METRIC UNLESS OTHERWISE NOTED.  
MATERIAL: SAE 4140 or SAE 1045

STAMP OR ETCH THE NAAMS CODE NUMBER AND THE CLAMP ARM MANUFACTURER'S NUMBER, IF DIFFERENT, ON THE SIDE OF THE ARM.

PAINT AS PRESCRIBED ON PAGE G-1.2

THIS STANDARD BECOMES EFFECTIVE SEPTEMBER 1ST 2007

TABULATED INFORMATION ON FOLLOWING PAGE

# WISHBONE CLAMP ARMS 60 SERIES 70mm OFFSET

EXCEPT AS NOTED TOLERANCES SHALL BE:

- 1 PLACE MACHINING  $\pm 0.3$
- 1 PLACE FABRICATION  $\pm 1.5$
- 2 PLACE  $\pm 0.03$  GENERAL
  - $\pm 0.03$  BETWEEN DOWELS
  - $\pm 0.13$  TO SCREW HOLES

NOTES: ALL DIMENSIONS METRIC UNLESS OTHERWISE NOTED.

MATERIAL: SAE 4140 or SAE 1045

ARM NO.	A DWL	B	C DWL	D	E DWL	F	G DWL	J	K DWL	M	N DWL	P	Q DWL	L	O.A.L.	WEIGHT Kg [Lbs]
ACA330M	95	110	125	-	-	-	-	-	-	-	-	-	-	135	170	1.6 [3.4]
ACA331M	95	110	125	140	155	-	-	-	-	-	-	-	-	165	200	1.7 [3.7]
ACA332M	95	110	125	140	155	170	185	-	-	-	-	-	-	195	230	1.8 [3.9]
ACA333M	95	110	125	140	155	170	185	200	215	-	-	-	-	225	260	1.9 [4.2]
ACA334M	95	110	125	140	155	170	185	200	215	230	245	-	-	255	290	2.0 [4.4]
ACA335M	95	110	125	140	155	170	185	200	215	230	245	260	275	285	320	2.1 [4.7]

SEE DRAWING ON PREVIOUS PAGE

THIS STANDARD BECOMES EFFECTIVE SEPTEMBER 1ST 2007

# POWER CLAMP ARMS 50 SERIES

(STRAIGHT - MACHINED) (FULL METRIC)

GLOBAL STANDARD COMPONENTS



Assembly

09/05/12

A

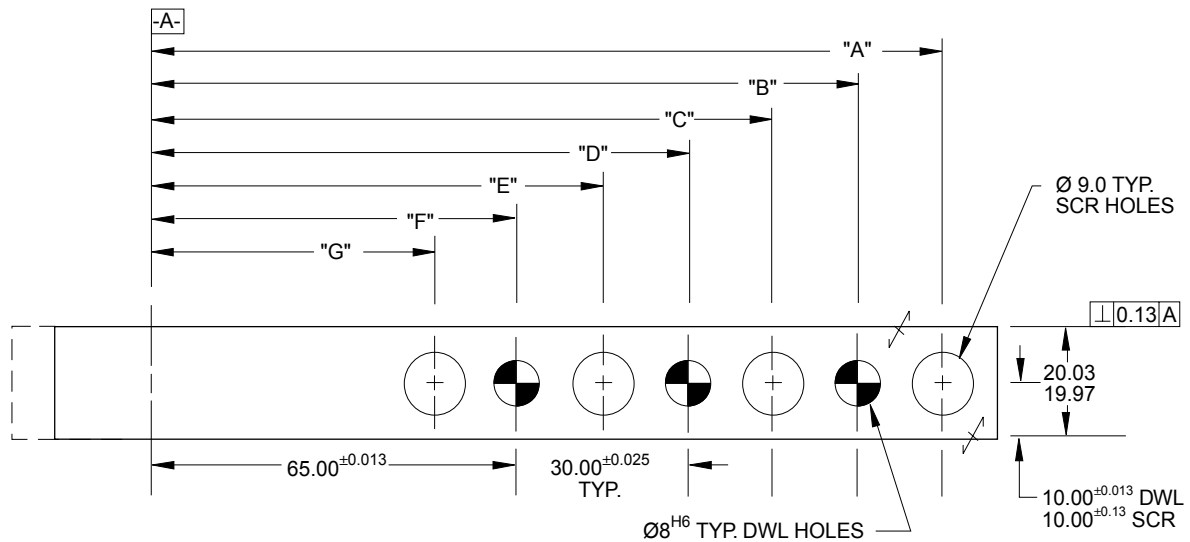
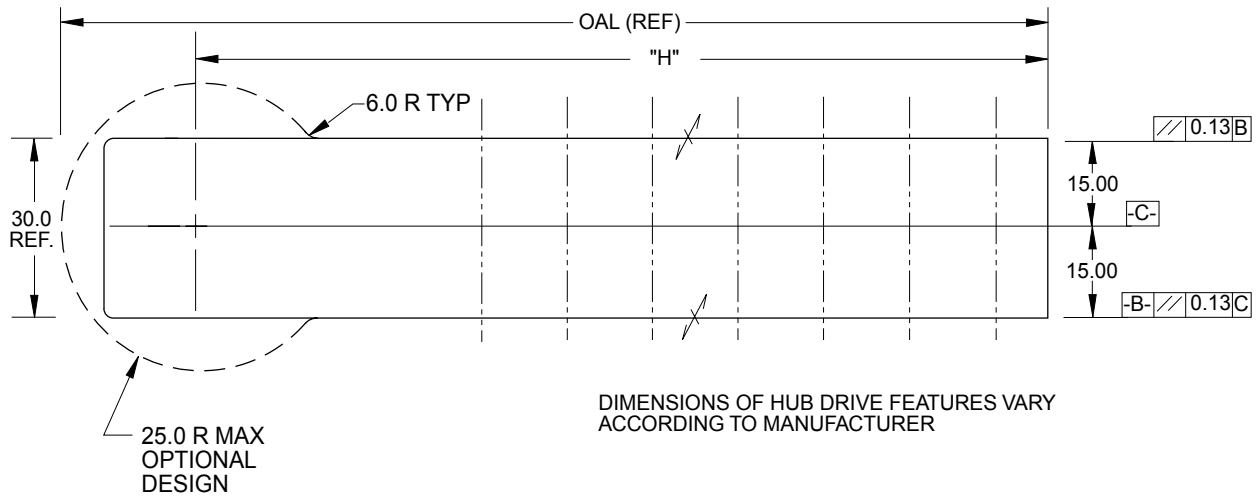

EXCEPT AS NOTED TOLERANCES SHALL BE:

- 1 PLACE MACHINING  $\pm 0.3$
- 1 PLACE FABRICATION  $\pm 1.5$
- 2 PLACE  $\pm 0.03$  GENERAL
- $\pm 0.03$  BETWEEN DOWELS
- $\pm 0.13$  TO SCREW HOLES

NOTES: ALL DIMENSIONS METRIC UNLESS OTHERWISE NOTED.

MATERIAL: SAE 4140 or SAE 1045

STAMP OR ETCH THE NAAMS CODE NUMBER AND THE CLAMP ARM MANUFACTURER'S NUMBER, IF DIFFERENT, ON THE SIDE OF THE ARM.

PAINT AS PRESCRIBED ON PAGE G-1.2

NAAMS CODE	DIM. "A"	DIM. "B"	DIM. "C"	DIM. "D"	DIM. "E"	DIM. "F"	DIM. "G"	DIM. "H" +1.5/-0.0	MAX OAL (REF)	WEIGHT kg
ACA401M	80.00	65.00	50.00					90.0	115.0	0.4
ACA402M	110.00	95.00	80.00	65.00	50.00			120.0	145.0	0.5
ACA403M	140.00	125.00	110.00	95.00	80.00	65.00	50.00	150.0	175.0	0.6



B

# POWER CLAMP ARMS 50 SERIES

(25mm OFFSET - MACHINED) (FULL METRIC)

GLOBAL STANDARD COMPONENTS



Assembly

09/05/12

A

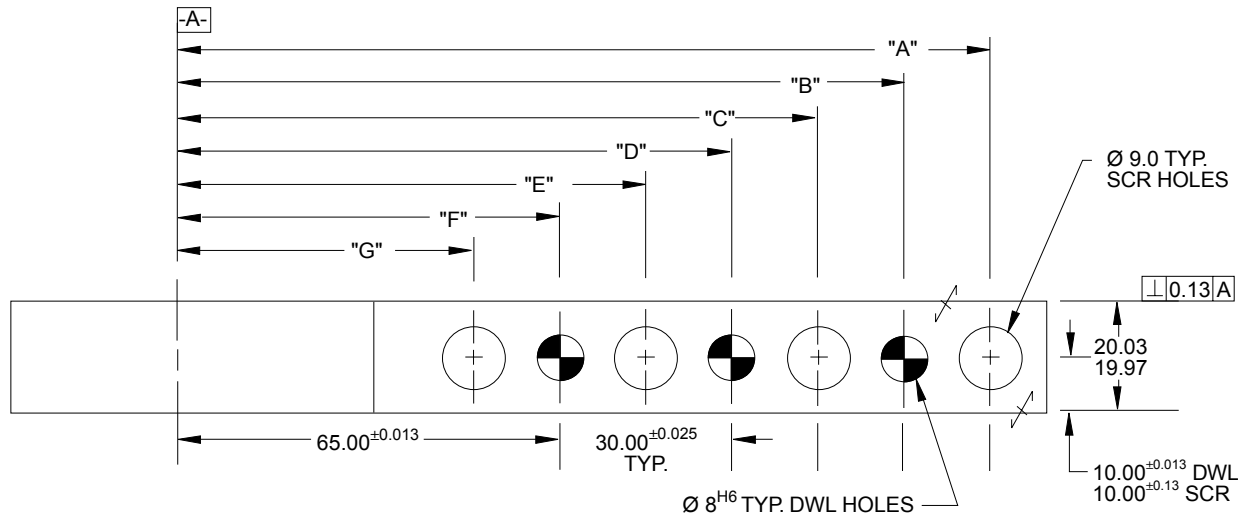
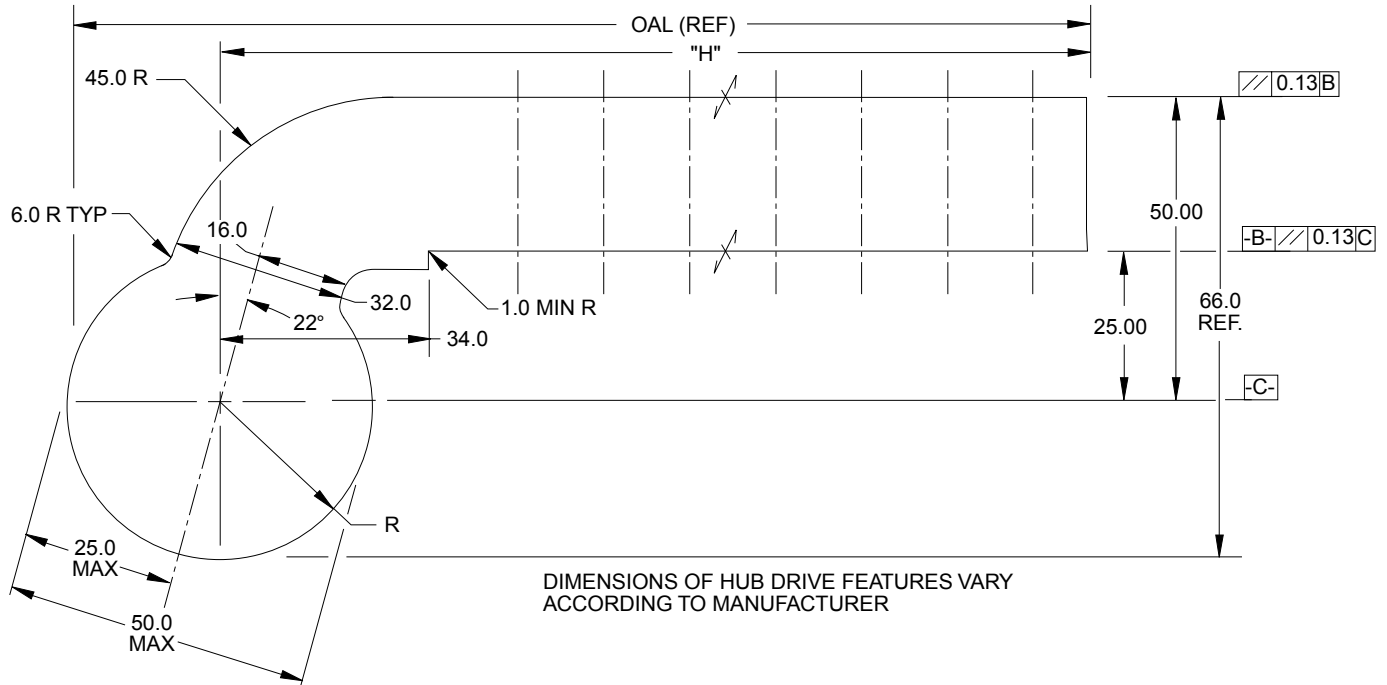

B

EXCEPT AS NOTED TOLERANCES SHALL BE:

- 1 PLACE MACHINING  $\pm 0.3$
- 1 PLACE FABRICATION  $\pm 1.5$
- 2 PLACE  $\pm 0.03$  GENERAL
- $\pm 0.03$  BETWEEN DOWELS
- $\pm 0.13$  TO SCREW HOLES

STAMP OR ETCH THE NAAMS CODE NUMBER AND THE CLAMP ARM MANUFACTURER'S NUMBER, IF DIFFERENT, ON THE SIDE OF THE ARM.

NOTES: ALL DIMENSIONS METRIC UNLESS OTHERWISE NOTED.  
MATERIAL: SAE 4140 or SAE 1045

PAIN T AS PRESCRIBED ON PAGE G-1.2

NAAMS CODE	DIM. "A"	DIM. "B"	DIM. "C"	DIM. "D"	DIM. "E"	DIM. "F"	DIM. "G"	DIM. "H" +1.5/-0.0	MAX OAL (REF)	WEIGHT kg
ACA411M	80.00	65.00	50.00					90.0	115.0	0.5
ACA412M	110.00	95.00	80.00	65.00	50.00			120.0	145.0	0.6
ACA413M	140.00	125.00	110.00	95.00	80.00	65.00	50.00	150.0	175.0	0.7



# POWER CLAMP ARMS 50 SERIES

(50mm OFFSET - MACHINED) (FULL METRIC)

GLOBAL STANDARD COMPONENTS



Assembly

09/05/12

A

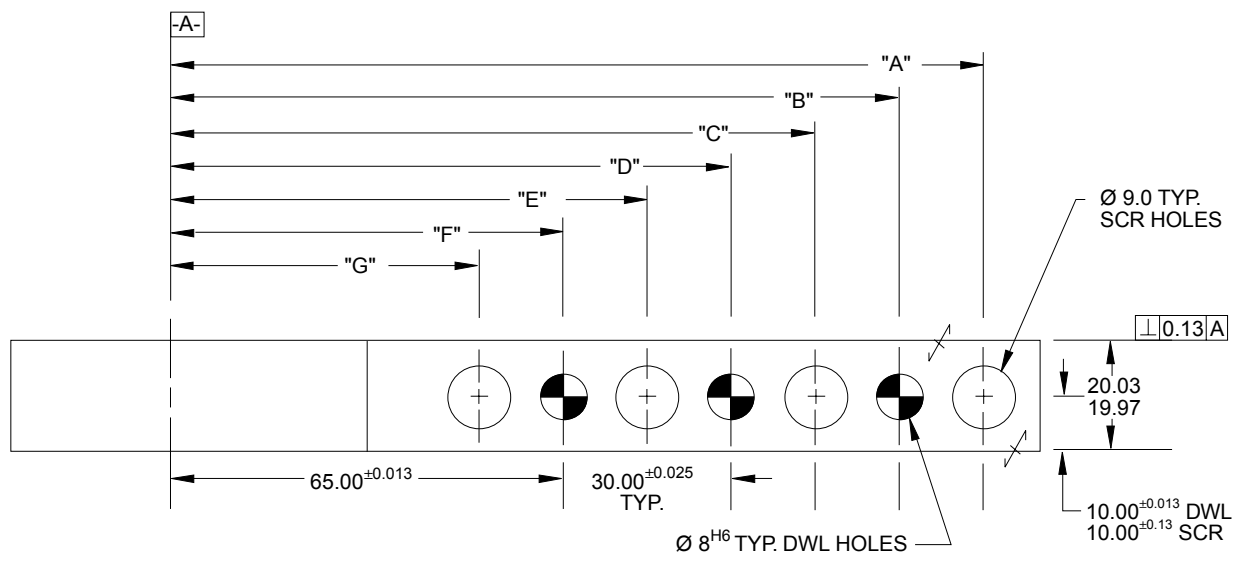
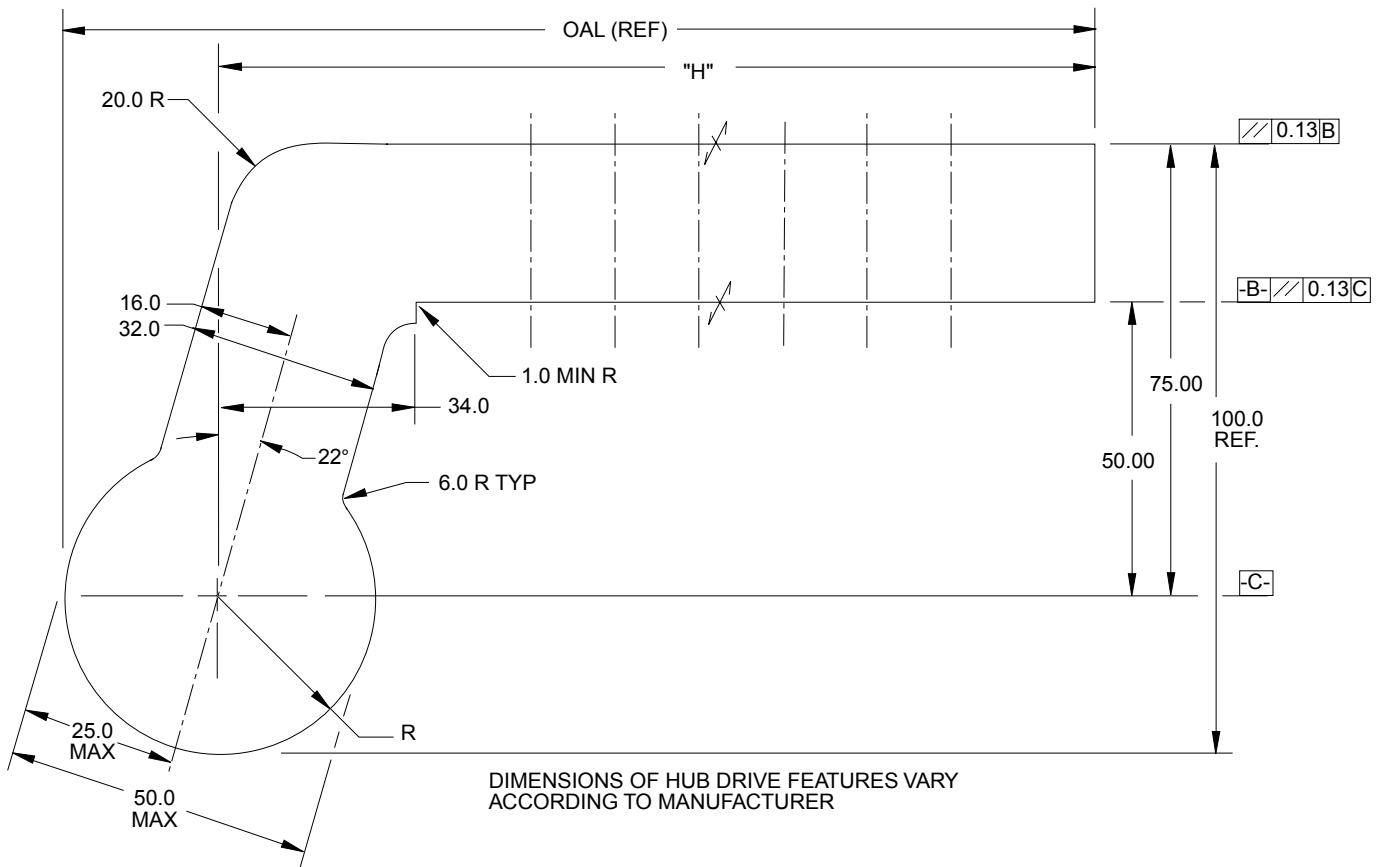

B

STAMP OR ETCH THE NAAMS CODE NUMBER AND THE CLAMP ARM MANUFACTURER'S NUMBER, IF DIFFERENT, ON THE SIDE OF THE ARM.

PAINT AS PRESCRIBED ON PAGE G-1.2

TABULATED INFORMATION ON FOLLOWING PAGE



# POWER CLAMP ARMS 50 SERIES

(50mm OFFSET - MACHINED) (FULL METRIC)

GLOBAL STANDARD COMPONENTS



Assembly

11/10/10

A

EXCEPT AS NOTED TOLERANCES SHALL BE:

- 1 PLACE MACHINING  $\pm 0.3$
- 1 PLACE FABRICATION  $\pm 1.5$
- 2 PLACE  $\pm 0.03$  GENERAL
  - $\pm 0.03$  BETWEEN DOWELS
  - $\pm 0.13$  TO SCREW HOLES

NOTES: ALL DIMENSIONS METRIC UNLESS OTHERWISE NOTED.

MATERIAL: SAE 4140 or SAE 1045

NAAMS CODE	DIM. "A"	DIM. "B"	DIM. "C"	DIM. "D"	DIM. "E"	DIM. "F"	DIM. "G"	DIM. "H" +1.5/-0.0	MAX OAL (REF)	WEIGHT kg
ACA421M	80.00	65.00	50.00					90.0	115.0	0.6
ACA422M	110.00	95.00	80.00	65.00	50.00			120.0	145.0	0.7
ACA423M	140.00	125.00	110.00	95.00	80.00	65.00	50.00	150.0	175.0	0.8

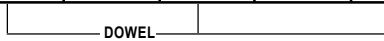

SEE DRAWING ON PREVIOUS PAGE

# WISHBONE CLAMP ARMS 50 SERIES 25mm OFFSET

GLOBAL STANDARD COMPONENTS



Assembly

09/05/12

A

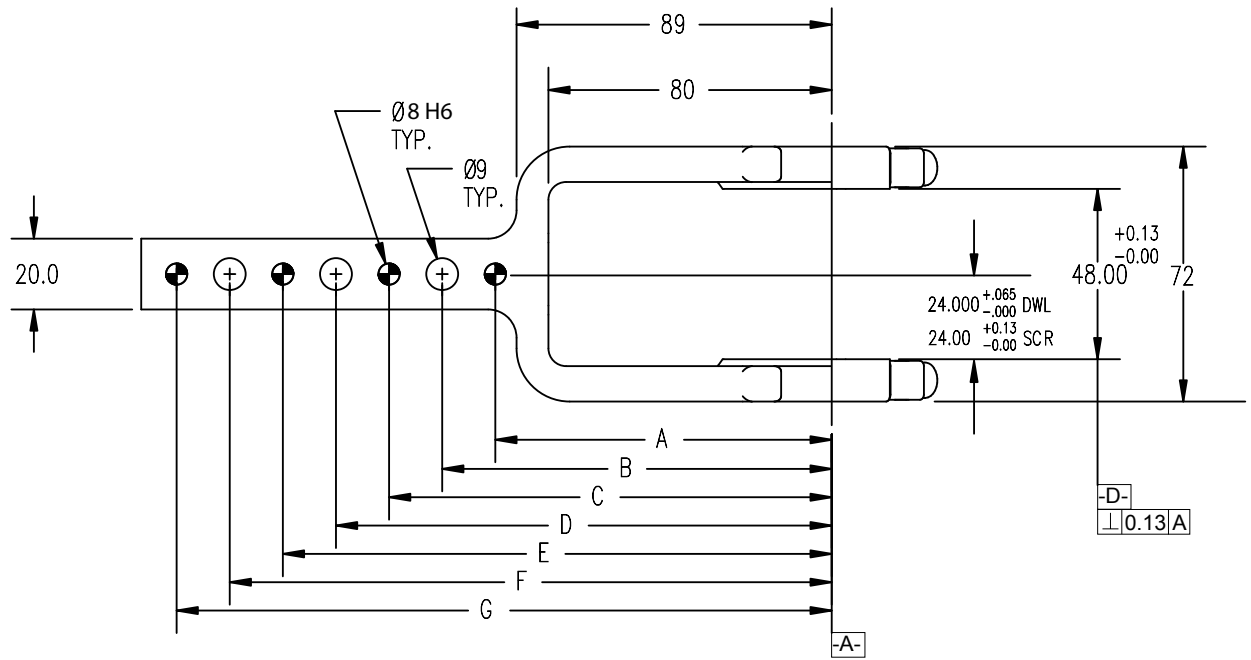

B

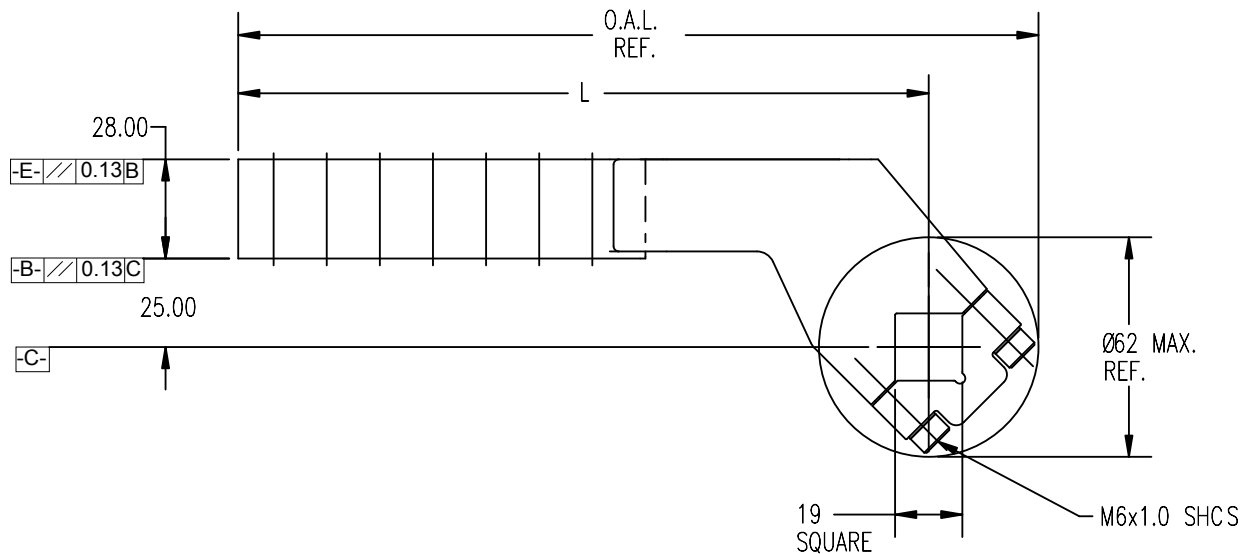

EXCEPT AS NOTED TOLERANCES SHALL BE:

- 1 PLACE MACHINING  $\pm 0.3$
- 1 PLACE FABRICATION  $\pm 1.5$
- 2 PLACE  $\pm 0.03$  GENERAL
- $\pm 0.03$  BETWEEN DOWELS
- $\pm 0.13$  TO SCREW HOLES

NOTES: ALL DIMENSIONS METRIC UNLESS OTHERWISE NOTED.  
MATERIAL: SAE 4140 or SAE 1045

STAMP OR ETCH THE NAAMS CODE NUMBER AND THE CLAMP ARM MANUFACTURER'S NUMBER, IF DIFFERENT, ON THE SIDE OF THE ARM.

PAINT AS PRESCRIBED ON PAGE G-1.2

THIS STANDARD BECOMES EFFECTIVE SEPTEMBER 1ST 2007

TABULATED INFORMATION ON FOLLOWING PAGE

# WISHBONE CLAMP ARMS 50 SERIES 25mm OFFSET

GLOBAL STANDARD COMPONENTS



Assembly

11/10/10

A

EXCEPT AS NOTED TOLERANCES SHALL BE:

- 1 PLACE MACHINING  $\pm 0.3$
- 1 PLACE FABRICATION  $\pm 1.5$
- 2 PLACE  $\pm 0.03$  GENERAL
  - $\pm 0.03$  BETWEEN DOWELS
  - $\pm 0.13$  TO SCREW HOLES

NOTES: ALL DIMENSIONS METRIC UNLESS OTHERWISE NOTED.

MATERIAL: SAE 4140 or SAE 1045

ARM NO.	A DWL	B	C DWL	D	E DWL	F	G DWL	L	O.A.L.	WEIGHT Kg [Lbs]
ACA431M	95	110	125	-	-	-	-	135	166	0.9 [2.0]
ACA432M	95	110	125	140	155	-	-	165	196	1.0 [2.2]
ACA433M	95	110	125	140	155	170	185	195	226	1.2 [2.6]

SEE DRAWING ON PREVIOUS PAGE

THIS STANDARD BECOMES EFFECTIVE SEPTEMBER 1ST 2007

# WISHBONE CLAMP ARMS 50 SERIES 50mm OFFSET

A  
B

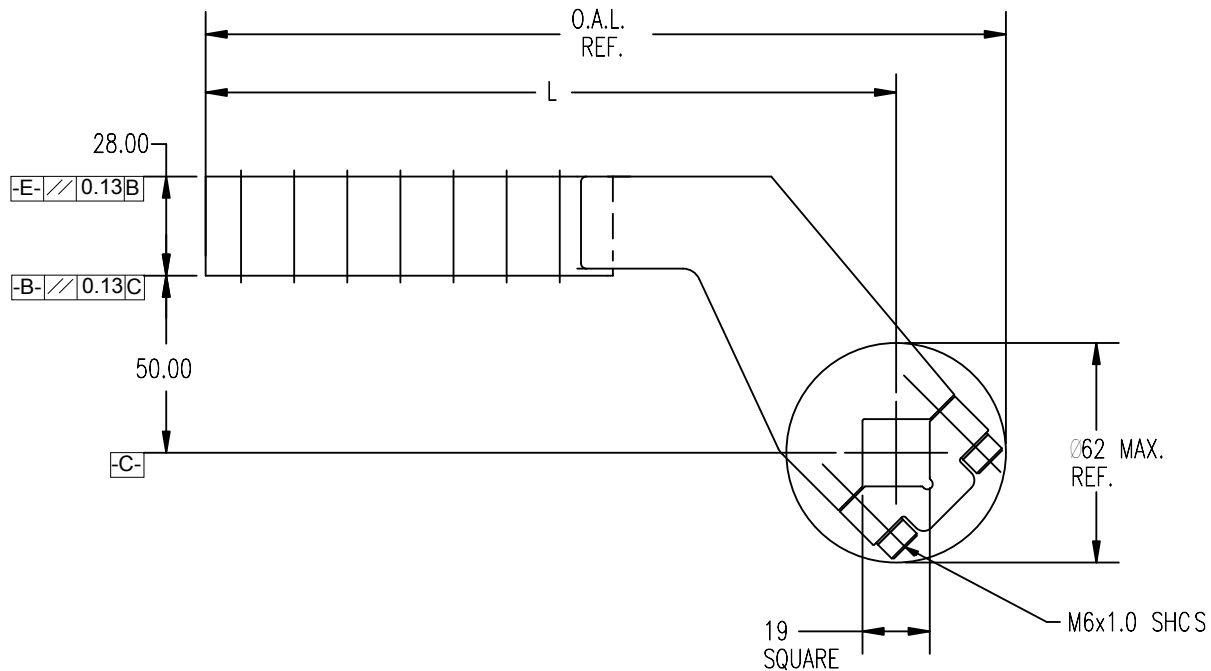
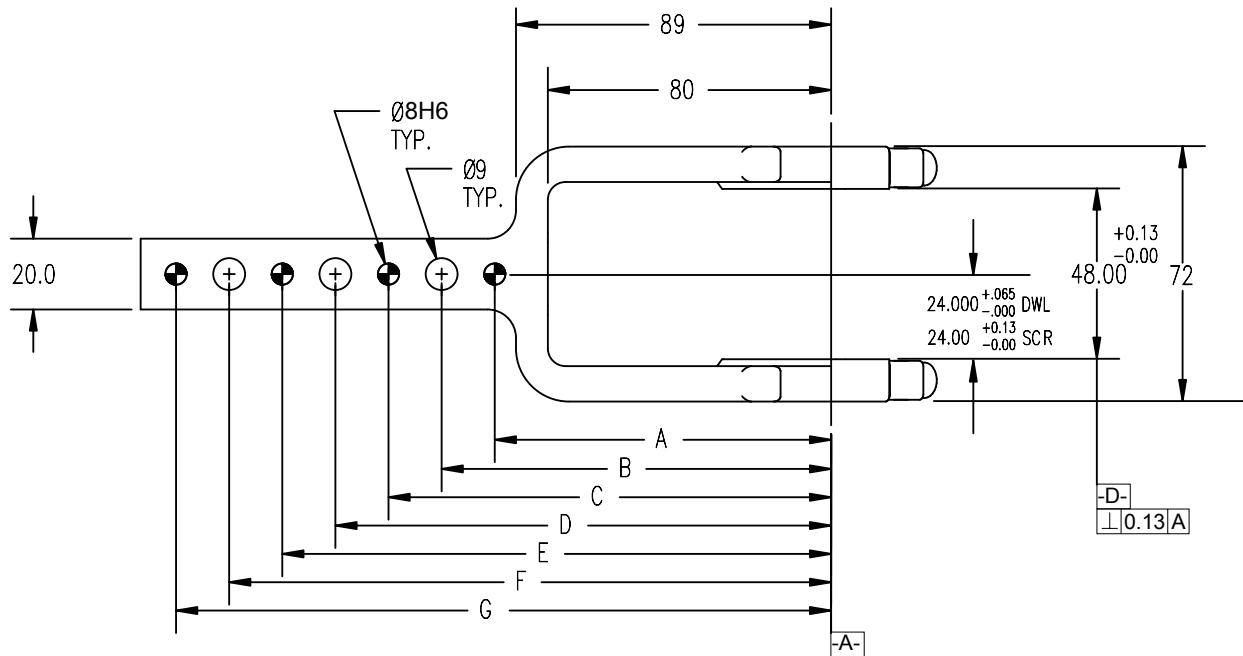

EXCEPT AS NOTED TOLERANCES SHALL BE:

- 1 PLACE MACHINING ±0.3
- 1 PLACE FABRICATION ±1.5
- 2 PLACE ±0.03 GENERAL
- ±0.03 BETWEEN DOWELS
- ±0.13 TO SCREW HOLES

NOTES: ALL DIMENSIONS METRIC UNLESS OTHERWISE NOTED.  
 MATERIAL: SAE 4140 or SAE 1045

STAMP OR ETCH THE NAAMS CODE NUMBER AND THE CLAMP ARM MANUFACTURER'S NUMBER, IF DIFFERENT, ON THE SIDE OF THE ARM.

PAINT AS PRESCRIBED ON PAGE G-1.2

THIS STANDARD BECOMES EFFECTIVE SEPTEMBER 1ST 2007

TABULATED INFORMATION ON FOLLOWING PAGE

# WISHBONE CLAMP ARMS 50 SERIES 50mm OFFSET

GLOBAL STANDARD COMPONENTS



Assembly

11/10/10

A

EXCEPT AS NOTED TOLERANCES SHALL BE:

- 1 PLACE MACHINING  $\pm 0.3$
- 1 PLACE FABRICATION  $\pm 1.5$
- 2 PLACE  $\pm 0.03$  GENERAL
  - $\pm 0.03$  BETWEEN DOWELS
  - $\pm 0.13$  TO SCREW HOLES

NOTES: ALL DIMENSIONS METRIC UNLESS OTHERWISE NOTED.

MATERIAL: SAE 4140 or SAE 1045

ARM NO.	A DWL	B	C DWL	D	E DWL	F	G DWL	L	O.A.L.	WEIGHT Kg [Lbs]
ACA441M	95	110	125	-	-	-	-	135	166	1.1 [2.4]
ACA442M	95	110	125	140	155	-	-	165	196	1.2 [2.7]
ACA443M	95	110	125	140	155	170	185	195	226	1.4 [3.0]

SEE DRAWING ON PREVIOUS PAGE

THIS STANDARD BECOMES EFFECTIVE SEPTEMBER 1ST 2007

# WISHBONE CLAMP ARMS 60 SERIES 25mm OFFSET

A

B

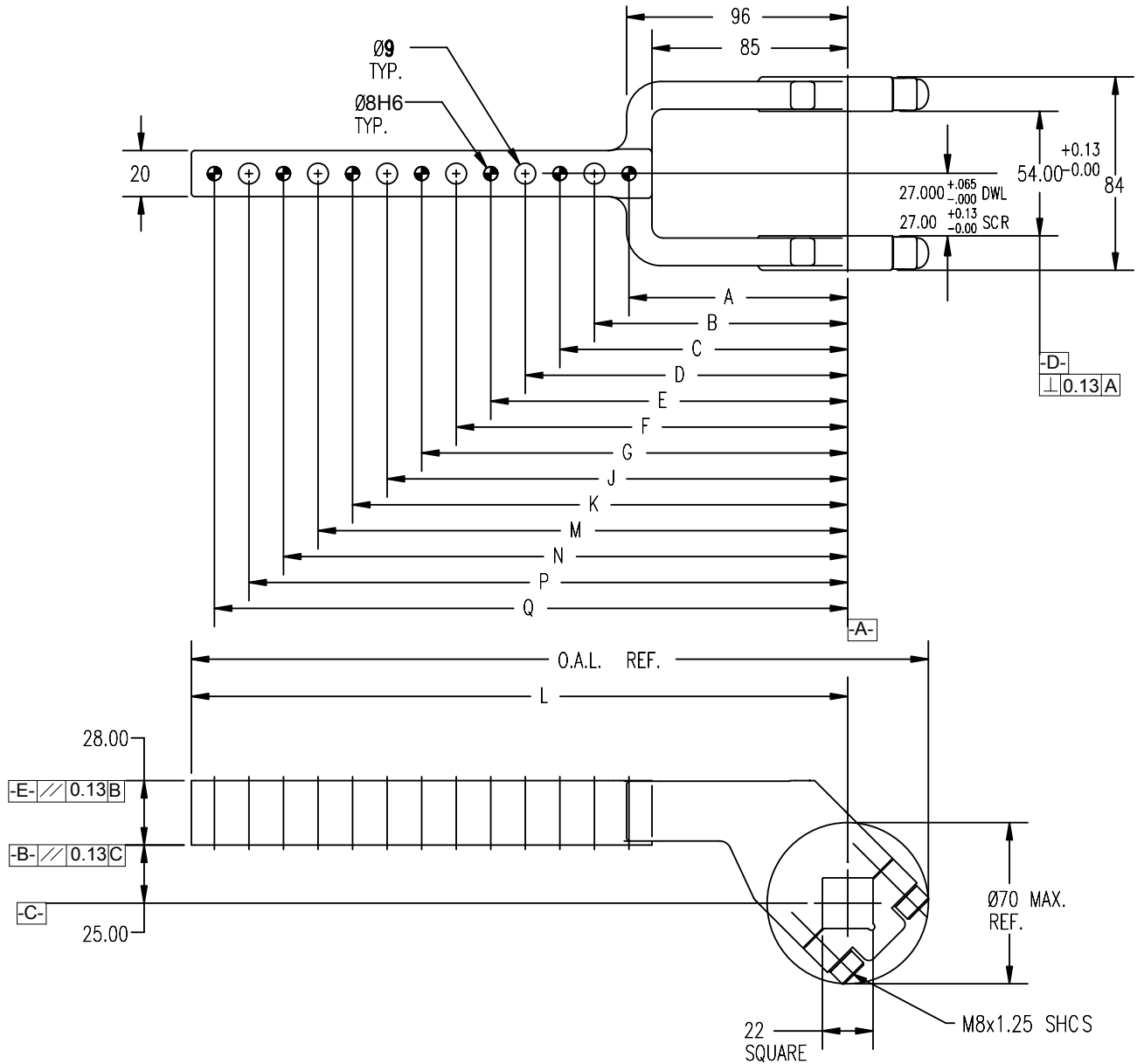

EXCEPT AS NOTED TOLERANCES SHALL BE:

- 1 PLACE MACHINING  $\pm 0.3$
- 1 PLACE FABRICATION  $\pm 1.5$
- 2 PLACE  $\pm 0.03$  GENERAL
- $\pm 0.03$  BETWEEN DOWELS
- $\pm 0.13$  TO SCREW HOLES

NOTES: ALL DIMENSIONS METRIC UNLESS OTHERWISE NOTED.  
 MATERIAL: SAE 4140 or SAE 1045

STAMP OR ETCH THE NAAMS CODE NUMBER AND THE CLAMP ARM MANUFACTURER'S NUMBER, IF DIFFERENT, ON THE SIDE OF THE ARM.

PAIN T AS PRESCRIBED ON PAGE G-1.2

THIS STANDARD BECOMES EFFECTIVE SEPTEMBER 1ST 2007

TABULATED INFORMATION ON FOLLOWING PAGE

# WISHBONE CLAMP ARMS 60 SERIES 25mm OFFSET

GLOBAL STANDARD COMPONENTS



Assembly

11/10/10

A

EXCEPT AS NOTED TOLERANCES SHALL BE:

- 1 PLACE MACHINING  $\pm 0.3$
- 1 PLACE FABRICATION  $\pm 1.5$
- 2 PLACE  $\pm 0.03$  GENERAL
- $\pm 0.03$  BETWEEN DOWELS
- $\pm 0.13$  TO SCREW HOLES

NOTES: ALL DIMENSIONS METRIC UNLESS OTHERWISE NOTED.

MATERIAL: SAE 4140 or SAE 1045

ARM NO.	A DWL	B	C DWL	D	E DWL	F	G DWL	J	K DWL	M	N DWL	P	Q DWL	L	O.A.L.	WEIGHT Kg [Lbs]
ACA451M	95	110	125	-	-	-	-	-	-	-	-	-	-	135	170	1.3 [2.8]
ACA452M	95	110	125	140	155	-	-	-	-	-	-	-	-	165	200	1.4 [3.1]
ACA453M	95	110	125	140	155	170	185	-	-	-	-	-	-	195	230	1.5 [3.3]
ACA454M	95	110	125	140	155	170	185	200	215	-	-	-	-	225	260	1.6 [3.6]
ACA455M	95	110	125	140	155	170	185	200	215	230	245	-	-	255	290	1.7 [3.8]
ACA456M	95	110	125	140	155	170	185	200	215	230	245	260	275	285	320	1.8 [4.0]

SEE DRAWING ON PREVIOUS PAGE

THIS STANDARD BECOMES EFFECTIVE SEPTEMBER 1ST 2007

# WISHBONE CLAMP ARMS 60 SERIES 70mm OFFSET

GLOBAL STANDARD COMPONENTS



Assembly

09/05/12

A

B

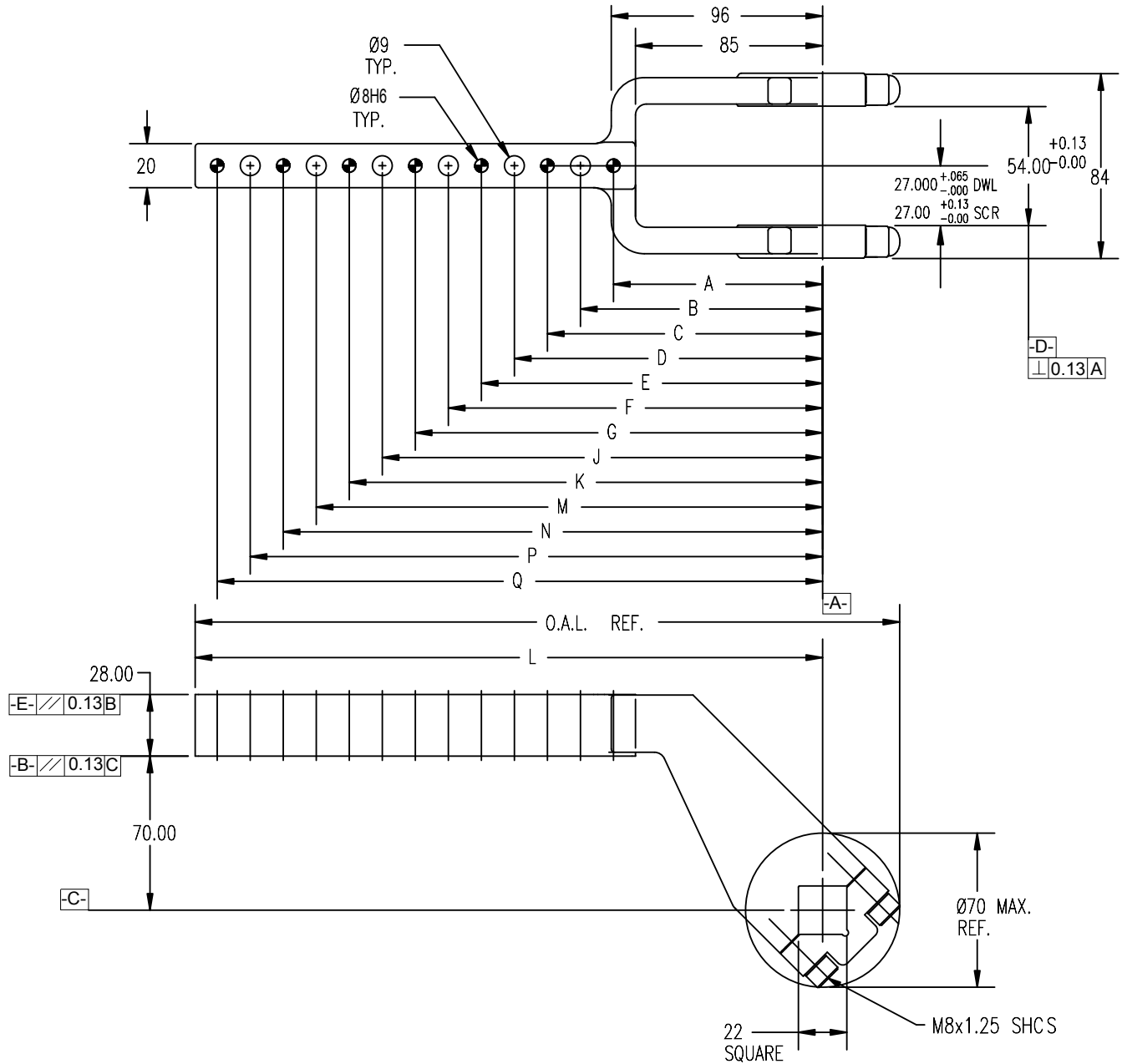

EXCEPT AS NOTED TOLERANCES SHALL BE:

- 1 PLACE MACHINING  $\pm 0.3$
- 1 PLACE FABRICATION  $\pm 1.5$
- 2 PLACE  $\pm 0.03$  GENERAL
- $\pm 0.03$  BETWEEN DOWELS
- $\pm 0.13$  TO SCREW HOLES

NOTES: ALL DIMENSIONS METRIC UNLESS OTHERWISE NOTED.  
MATERIAL: SAE 4140 or SAE 1045

STAMP OR ETCH THE NAAMS CODE NUMBER AND THE CLAMP ARM MANUFACTURER'S NUMBER, IF DIFFERENT, ON THE SIDE OF THE ARM.

PAINT AS PRESCRIBED ON PAGE G-1.2

THIS STANDARD BECOMES EFFECTIVE SEPTEMBER 1ST 2007

TABULATED INFORMATION ON FOLLOWING PAGE



# WISHBONE CLAMP ARMS 60 SERIES 70mm OFFSET

GLOBAL STANDARD COMPONENTS



Assembly

11/10/10

A

EXCEPT AS NOTED TOLERANCES SHALL BE:

- 1 PLACE MACHINING  $\pm 0.3$
- 1 PLACE FABRICATION  $\pm 1.5$
- 2 PLACE  $\pm 0.03$  GENERAL
  - $\pm 0.03$  BETWEEN DOWELS
  - $\pm 0.13$  TO SCREW HOLES

NOTES: ALL DIMENSIONS METRIC UNLESS OTHERWISE NOTED.

MATERIAL: SAE 4140 or SAE 1045

ARM NO.	A DWL	B	C DWL	D	E DWL	F	G DWL	J	K DWL	M	N DWL	P	Q DWL	L	O.A.L.	WEIGHT Kg [Lbs]
ACA461M	95	110	125	-	-	-	-	-	-	-	-	-	-	135	170	1.6 [3.4]
ACA462M	95	110	125	140	155	-	-	-	-	-	-	-	-	165	200	1.7 [3.7]
ACA463M	95	110	125	140	155	170	185	-	-	-	-	-	-	195	230	1.8 [3.9]
ACA464M	95	110	125	140	155	170	185	200	215	-	-	-	-	225	260	1.9 [4.2]
ACA465M	95	110	125	140	155	170	185	200	215	230	245	-	-	255	290	2.0 [4.4]
ACA466M	95	110	125	140	155	170	185	200	215	230	245	260	275	285	320	2.1 [4.7]

SEE DRAWING ON PREVIOUS PAGE

THIS STANDARD BECOMES EFFECTIVE SEPTEMBER 1ST 2007

# POWER CLAMP ARMS 60 SERIES

(STRAIGHT - MACHINED) (20mm WIDE)

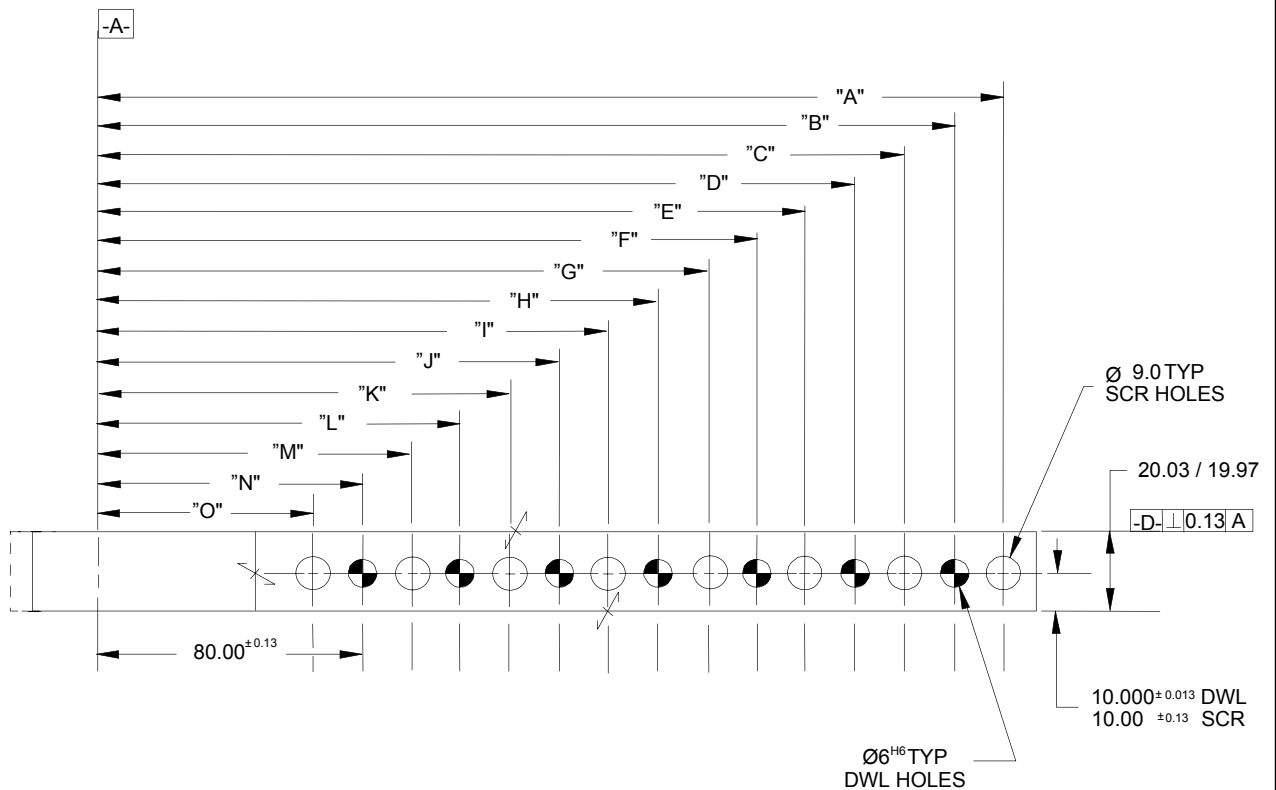
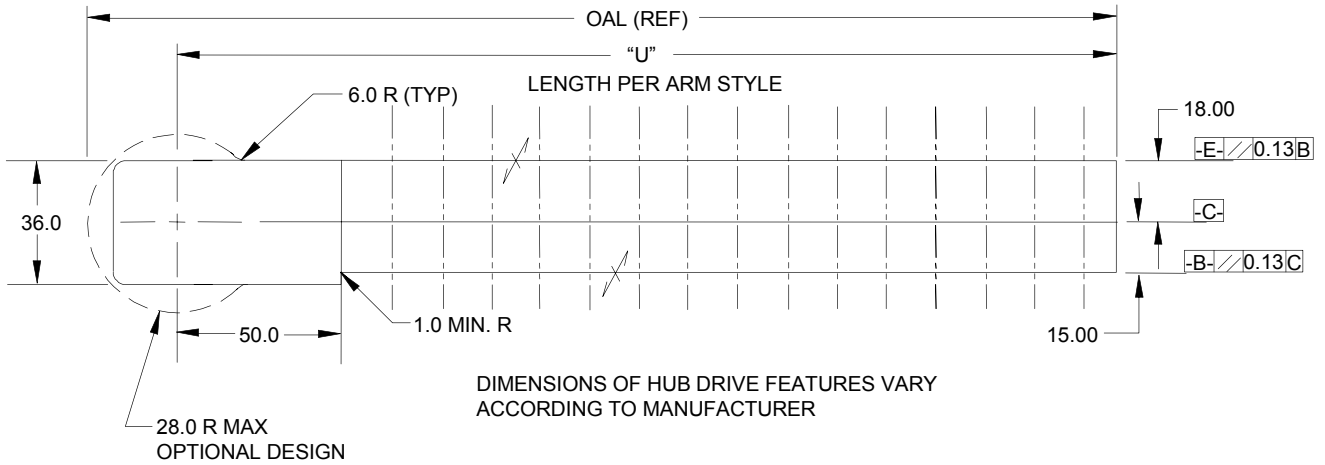

STAMP OR ETCH THE NAAMS CODE NUMBER AND THE CLAMP ARM  
MANUFACTURER'S NUMBER, IF DIFFERENT, ON THE SIDE OF THE ARM.

PAINT AS PRESCRIBED ON PAGE G-1.2

TABULATED INFORMATION ON FOLLOWING PAGE

# POWER CLAMP ARMS 60 SERIES

(STRAIGHT - MACHINED) (20mm WIDE)

A

EXCEPT AS NOTED TOLERANCES SHALL BE:

- 1 PLACE MACHINING  $\pm 0.3$
- 1 PLACE FABRICATION  $\pm 1.5$
- 2 PLACE  $\pm 0.03$  GENERAL
- $\pm 0.03$  BETWEEN DOWELS
- $\pm 0.13$  TO SCREW HOLES

NOTES: ALL DIMENSIONS METRIC UNLESS OTHERWISE NOTED.

MATERIAL: SAE 4140 or SAE 1045

NAAMS CODE	DIM "U" +1.5/-0.0	MAX OAL (REF)	Weight kg*	Dim. "A"	Dim. "B"	Dim. "C"	Dim. "D"	Dim. "E"	Dim. "F"	Dim. "G"	Dim. "H"	Dim. "I"	Dim. "J"	Dim. "K"	Dim. "L"	Dim. "M"
ACA507M	135.0	163.0	1.0	125.00	110.00	95.00	80.00	65.00								
ACA508M	165.0	193.0	1.2	155.00	140.00	125.00	110.00	95.00	80.00	65.00						
ACA509M	195.0	223.0	1.3	185.00	170.00	155.00	140.00	125.00	110.00	95.00	80.00	65.00				
ACA510M	225.0	253.0	1.4	215.00	200.00	185.00	170.00	155.00	140.00	125.00	110.00	95.00	80.00	65.00		
ACA511M	255.0	283.0	1.6	245.00	230.00	215.00	200.00	185.00	170.00	155.00	140.00	125.00	110.00	95.00	80.00	65.00
ACA512M	285.0	313.0	1.8	275.00	260.00	245.00	230.00	215.00	200.00	185.00	170.00	155.00	140.00	125.00	110.00	95.00



NAAMS CODE	Dim. "N"	Dim. "O"
ACA512M	80.00	65.00



\* Weight of arm as shown. Actual weight may vary due to variations in mounting details.

SEE DRAWING ON PREVIOUS PAGE

# POWER CLAMP ARMS 60 SERIES

(25mm OFFSET - MACHINED) (20mm WIDE)

Assembly

09/05/12

A

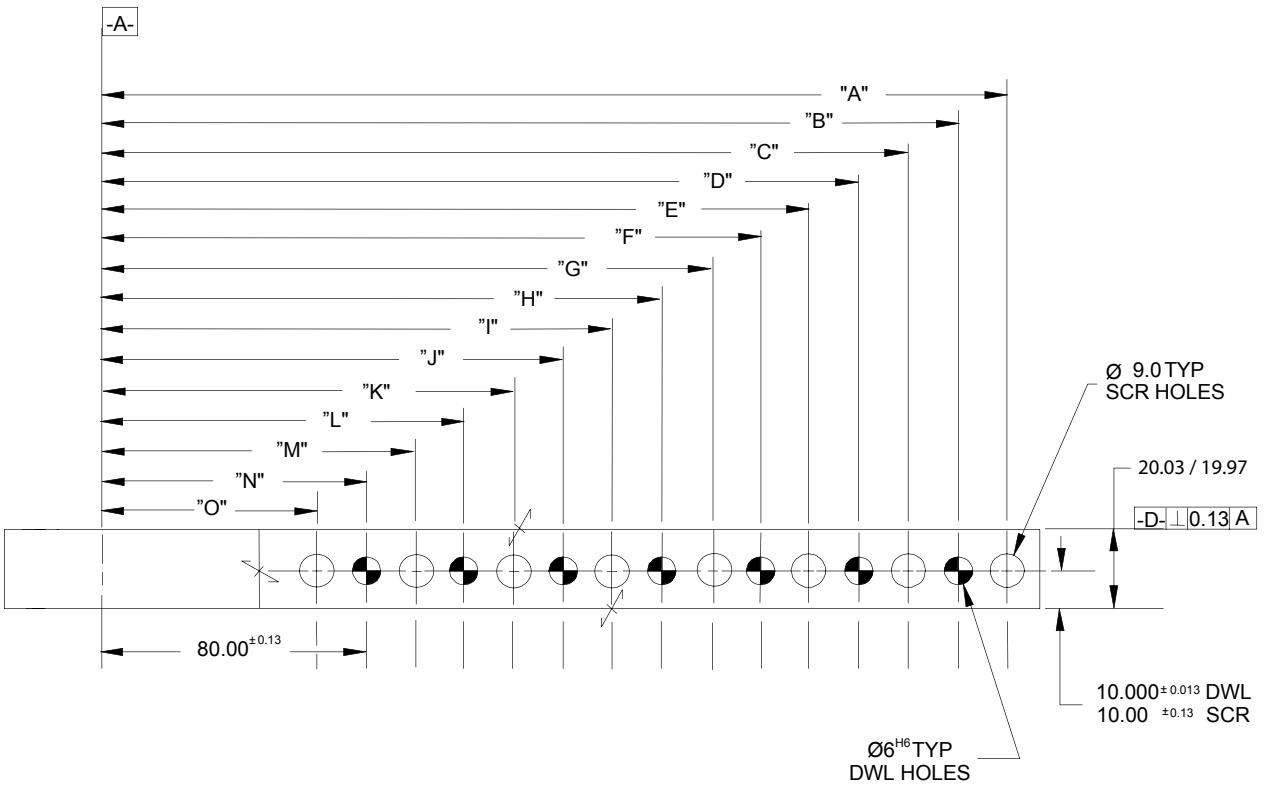
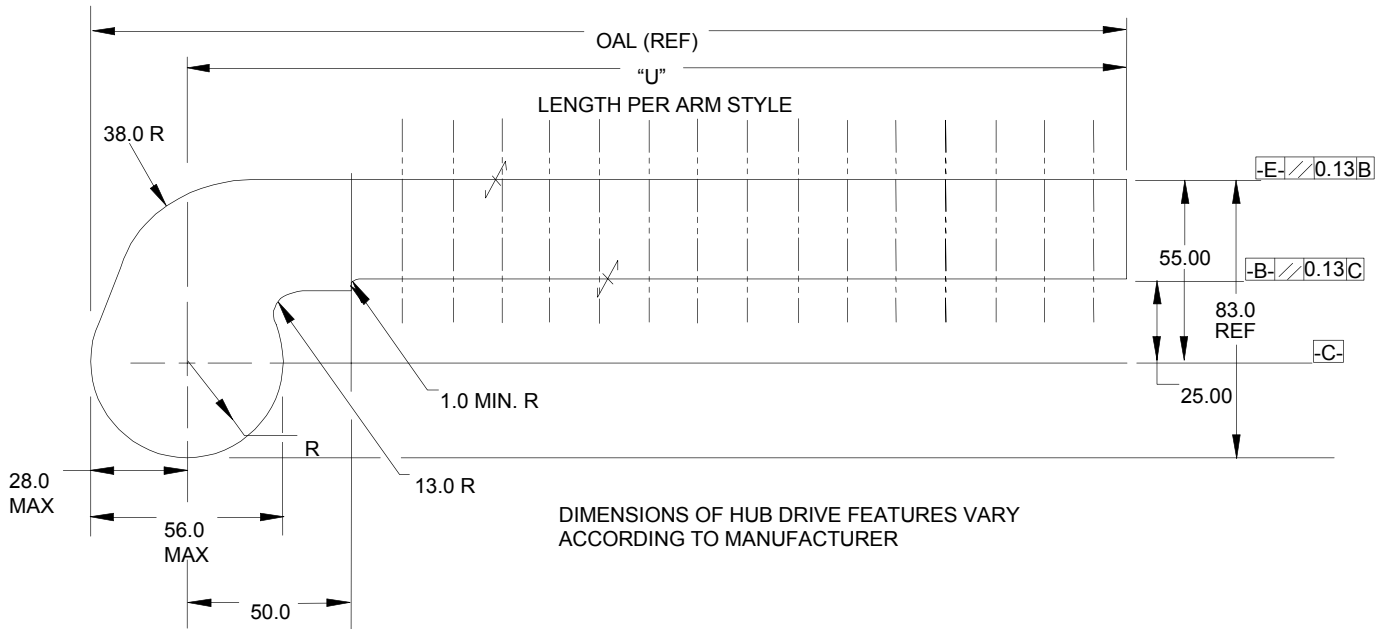

B

STAMP OR ETCH THE NAAMS CODE NUMBER AND THE CLAMP ARM MANUFACTURER'S NUMBER, IF DIFFERENT, ON THE SIDE OF THE ARM.

PAINT AS PRESCRIBED ON PAGE G-1.2

TABULATED INFORMATION ON FOLLOWING PAGE

# POWER CLAMP ARMS 60 SERIES

(25mm OFFSET - MACHINED) (20mm WIDE)

GLOBAL STANDARD COMPONENTS



TM

Assembly

11/10/10

A

EXCEPT AS NOTED TOLERANCES SHALL BE:

- 1 PLACE MACHINING  $\pm 0.3$
- 1 PLACE FABRICATION  $\pm 1.5$
- 2 PLACE  $\pm 0.03$  GENERAL
  - $\pm 0.03$  BETWEEN DOWELS
  - $\pm 0.13$  TO SCREW HOLES

NOTES: ALL DIMENSIONS METRIC UNLESS OTHERWISE NOTED.

MATERIAL: SAE 4140 or SAE 1045

NAAMS CODE	DIM "U" +1.5/-0.0	MAX OAL (REF)	Weight kg*	Dim. "A"	Dim. "B"	Dim. "C"	Dim. "D"	Dim. "E"	Dim. "F"	Dim. "G"	Dim. "H"	Dim. "I"	Dim. "J"	Dim. "K"	Dim. "L"	Dim. "M"
ACA519M	135.0	163.0	1.1	125.00	110.00	95.00	80.00	65.00								
ACA520M	165.0	193.0	1.3	155.00	140.00	125.00	110.00	95.00	80.00	65.00						
ACA521M	195.0	223.0	1.4	185.00	170.00	155.00	140.00	125.00	110.00	95.00	80.00	65.00				
ACA522M	225.0	253.0	1.5	215.00	200.00	185.00	170.00	155.00	140.00	125.00	110.00	95.00	80.00	65.00		
ACA523M	255.0	283.0	1.6	245.00	230.00	215.00	200.00	185.00	170.00	155.00	140.00	125.00	110.00	95.00	80.00	65.00
ACA524M	285.0	313.0	1.9	275.00	260.00	245.00	230.00	215.00	200.00	185.00	170.00	155.00	140.00	125.00	110.00	95.00



DOWEL

NAAMS CODE	Dim. "N"	Dim. "O"
ACA524M	80.00	65.00

DOWEL

\* Weight of arm as shown. Actual weight may vary due to variations in mounting details.

SEE DRAWING ON PREVIOUS PAGE

# POWER CLAMP ARMS 60 SERIES

(70mm OFFSET - MACHINED) (20mm WIDE)

GLOBAL STANDARD COMPONENTS



Assembly

09/05/12

A

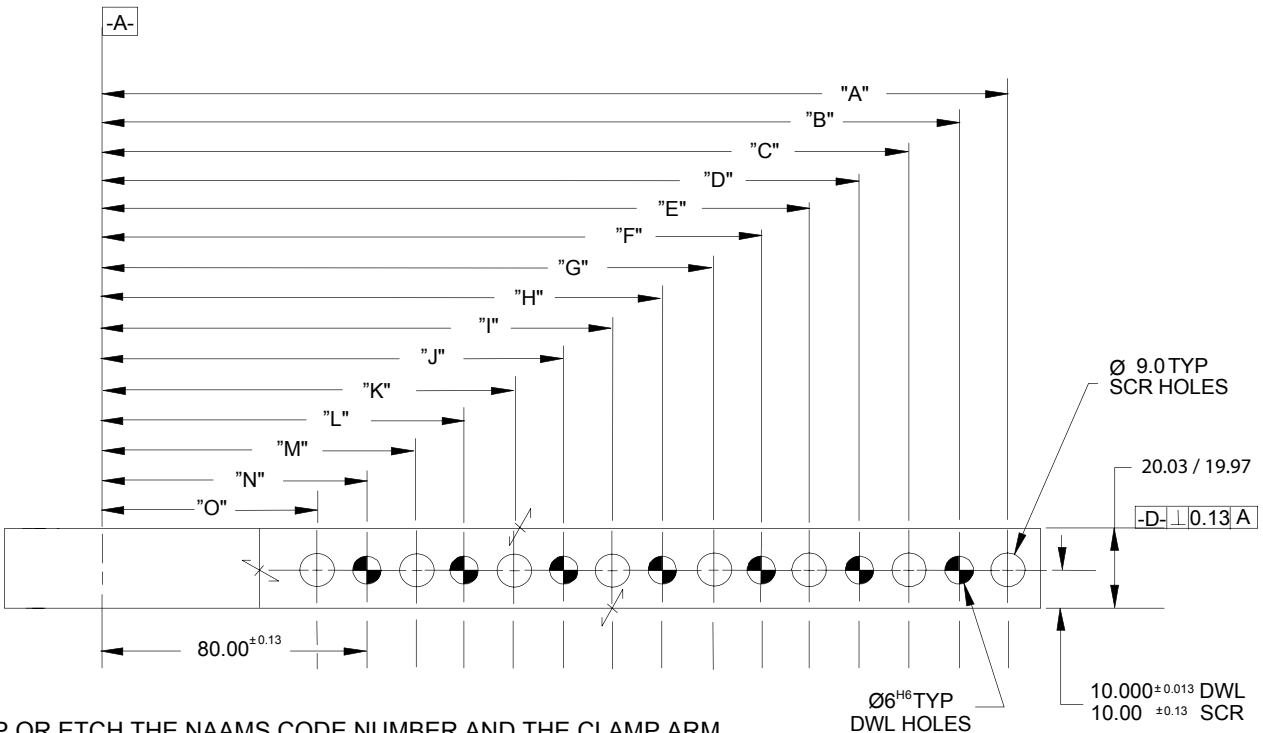
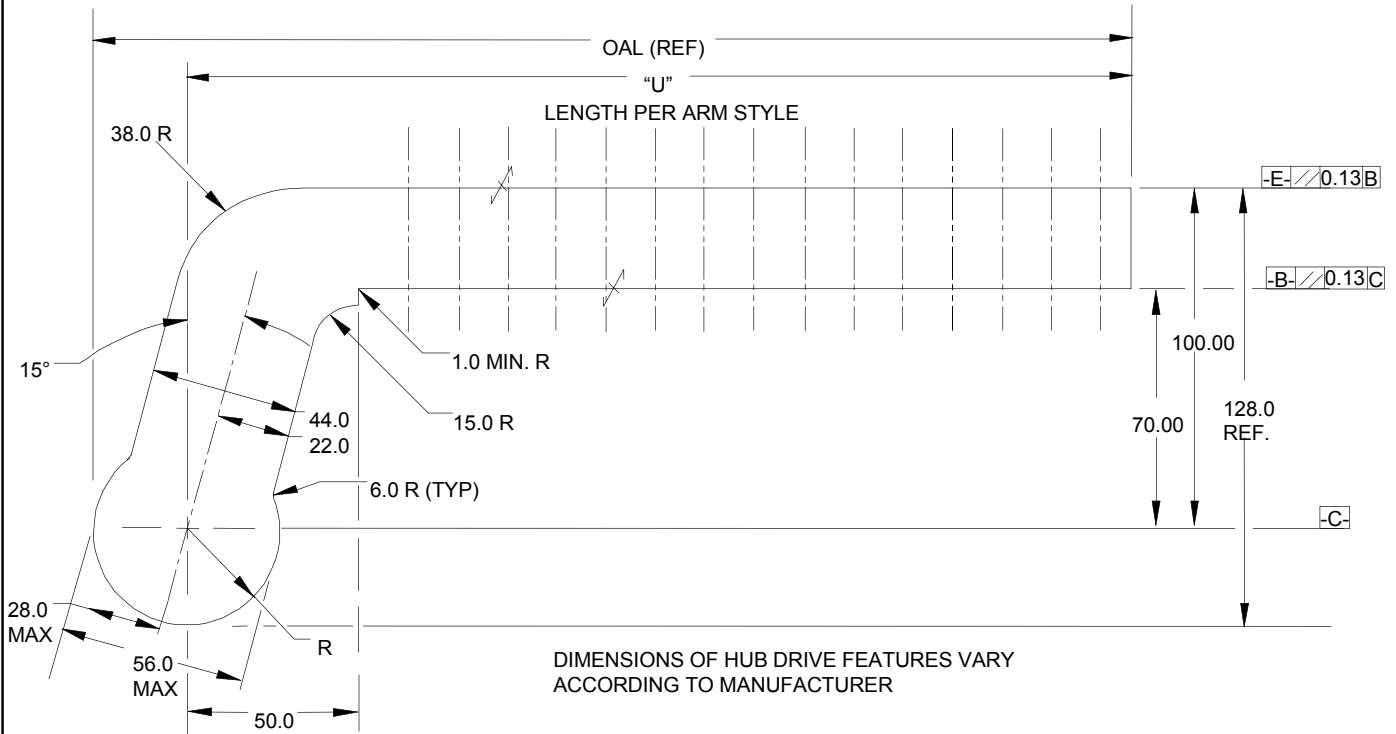

STAMP OR ETCH THE NAAMS CODE NUMBER AND THE CLAMP ARM MANUFACTURER'S NUMBER, IF DIFFERENT, ON THE SIDE OF THE ARM.

PAINT AS PRESCRIBED ON PAGE G-1.2

B

TABULATED INFORMATION ON FOLLOWING PAGE

# POWER CLAMP ARMS 60 SERIES

(70mm OFFSET - MACHINED) (20mm WIDE)

GLOBAL STANDARD COMPONENTS



Assembly

11/10/10

A

(FULL METRIC)

EXCEPT AS NOTED TOLERANCES SHALL BE:

- 1 PLACE MACHINING  $\pm 0.3$
- 1 PLACE FABRICATION  $\pm 1.5$
- 2 PLACE  $\pm 0.03$  GENERAL
- $\pm 0.03$  BETWEEN DOWELS
- $\pm 0.13$  TO SCREW HOLES

NOTES: ALL DIMENSIONS METRIC UNLESS OTHERWISE NOTED.

MATERIAL: SAE 4140 or SAE 1045

NAAMS CODE	DIM "U" +1.5/-0.0	MAX OAL (REF)	Weight kg*	Dim. "A"	Dim. "B"	Dim. "C"	Dim. "D"	Dim. "E"	Dim. "F"	Dim. "G"	Dim. "H"	Dim. "I"	Dim. "J"	Dim. "K"	Dim. "L"	Dim. "M"
ACA531M	135.0	163.0	1.5	125.00	110.00	95.00	80.00	65.00								
ACA532M	165.0	193.0	1.7	155.00	140.00	125.00	110.00	95.00	80.00	65.00						
ACA533M	195.0	223.0	1.7	185.00	170.00	155.00	140.00	125.00	110.00	95.00	80.00	65.00				
ACA534M	225.0	253.0	1.9	215.00	200.00	185.00	170.00	155.00	140.00	125.00	110.00	95.00	80.00	65.00		
ACA535M	255.0	283.0	2.0	245.00	230.00	215.00	200.00	185.00	170.00	155.00	140.00	125.00	110.00	95.00	80.00	65.00
ACA536M	285.0	313.0	2.2	275.00	260.00	245.00	230.00	215.00	200.00	185.00	170.00	155.00	140.00	125.00	110.00	95.00



NAAMS CODE	Dim. "N"	Dim. "O"
ACA536M	80.00	65.00

DOWEL

\* Weight of arm as shown. Actual weight may vary due to variations in mounting details.

SEE DRAWING ON PREVIOUS PAGE

# POWER CLAMP ARMS 60 SERIES

(120mm OFFSET - MACHINED) (20mm WIDE)

GLOBAL STANDARD COMPONENTS



Assembly

09/05/12

A

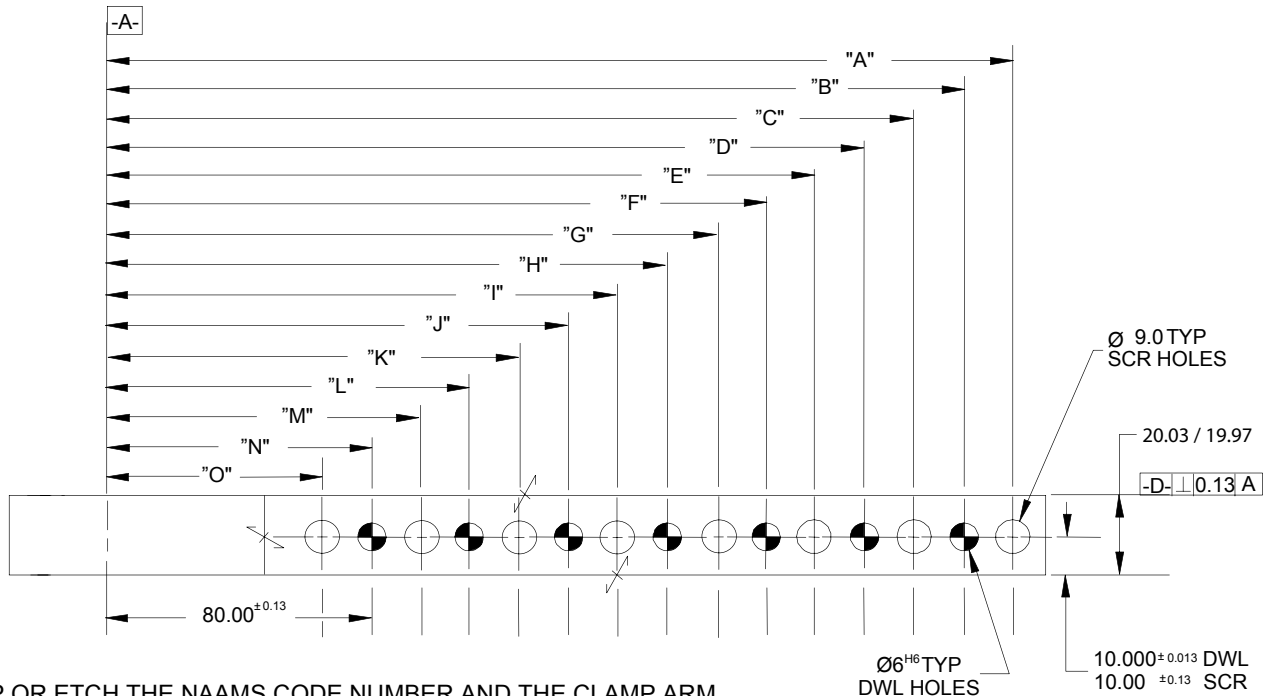
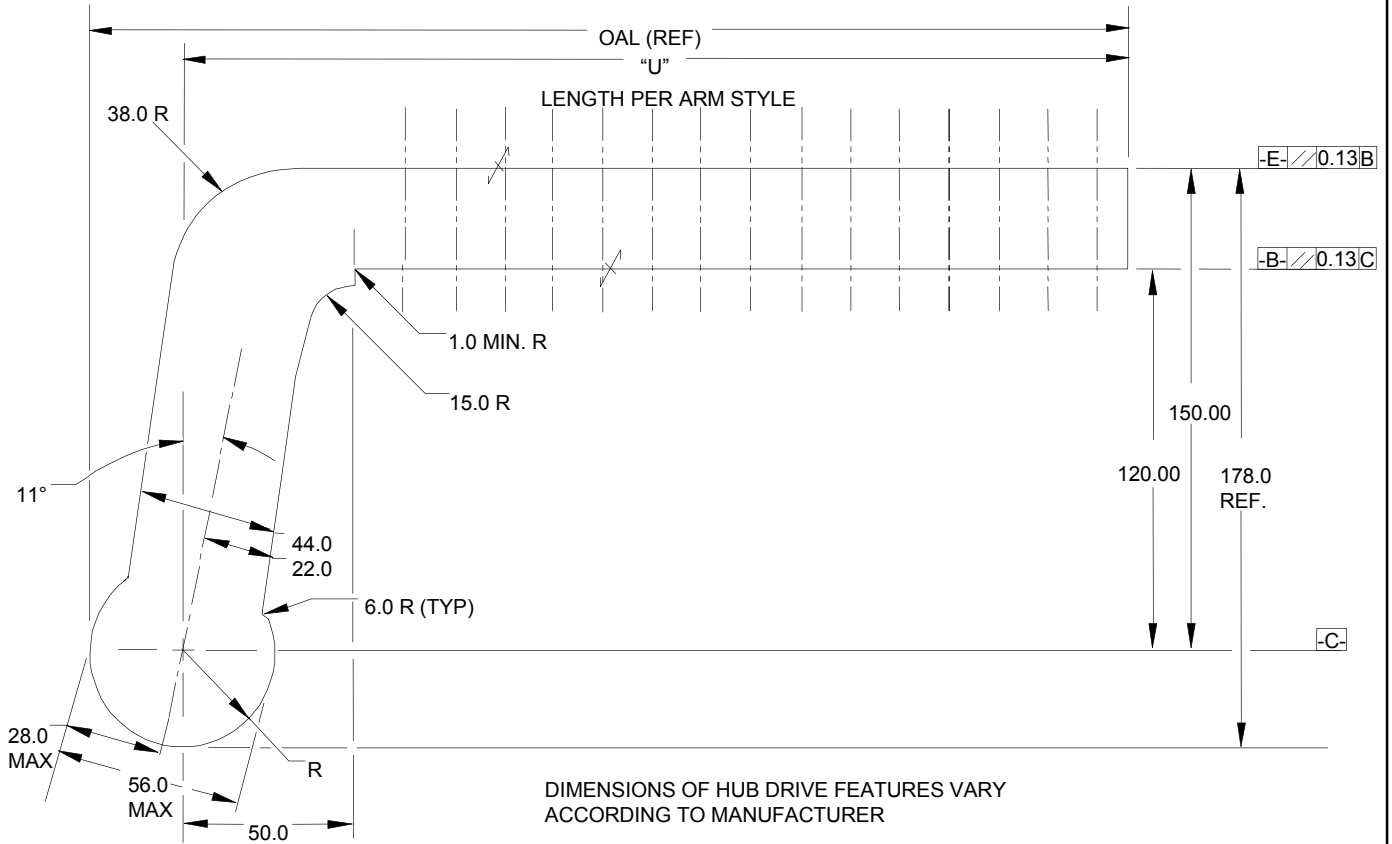

STAMP OR ETCH THE NAAMS CODE NUMBER AND THE CLAMP ARM MANUFACTURER'S NUMBER, IF DIFFERENT, ON THE SIDE OF THE ARM.  
PAINT AS PRESCRIBED ON PAGE G-1.2

B

TABULATED INFORMATION ON FOLLOWING PAGE



# POWER CLAMP ARMS 60 SERIES

(120mm OFFSET - MACHINED) (20mm WIDE)

GLOBAL STANDARD COMPONENTS



TM

Assembly

11/10/10

A

EXCEPT AS NOTED TOLERANCES SHALL BE:

- 1 PLACE MACHINING  $\pm 0.3$
- 1 PLACE FABRICATION  $\pm 1.5$
- 2 PLACE  $\pm 0.03$  GENERAL
  - $\pm 0.03$  BETWEEN DOWELS
  - $\pm 0.13$  TO SCREW HOLES

NOTES: ALL DIMENSIONS METRIC UNLESS OTHERWISE NOTED.

MATERIAL: SAE 4140 or SAE 1045

NAAMS CODE	DIM "U" +1.5/-0.0	MAX OAL (REF)	Weight kg*	Dim. "A"	Dim. "B"	Dim. "C"	Dim. "D"	Dim. "E"	Dim. "F"	Dim. "G"	Dim. "H"	Dim. "I"	Dim. "J"	Dim. "K"	Dim. "L"	Dim. "M"
ACA543M	135.0	163.0	1.9	125.00	110.00	95.00	80.00	65.00								
ACA544M	165.0	193.0	2.0	155.00	140.00	125.00	110.00	95.00	80.00	65.00						
ACA545M	195.0	223.0	2.1	185.00	170.00	155.00	140.00	125.00	110.00	95.00	80.00	65.00				
ACA546M	225.0	253.0	2.2	215.00	200.00	185.00	170.00	155.00	140.00	125.00	110.00	95.00	80.00	65.00		
ACA547M	255.0	283.0	2.4	245.00	230.00	215.00	200.00	185.00	170.00	155.00	140.00	125.00	110.00	95.00	80.00	65.00
ACA548M	285.0	313.0	2.6	275.00	260.00	245.00	230.00	215.00	200.00	185.00	170.00	155.00	140.00	125.00	110.00	95.00



NAAMS CODE	Dim. "N"	Dim. "O"
ACA548M	80.00	65.00

DOWEL

\* Weight of arm as shown. Actual weight may vary due to variations in mounting details.

SEE DRAWING ON PREVIOUS PAGE

# POWER CLAMP ARMS 60 SERIES (STRAIGHT - MACHINED) (20mm WIDE)

A

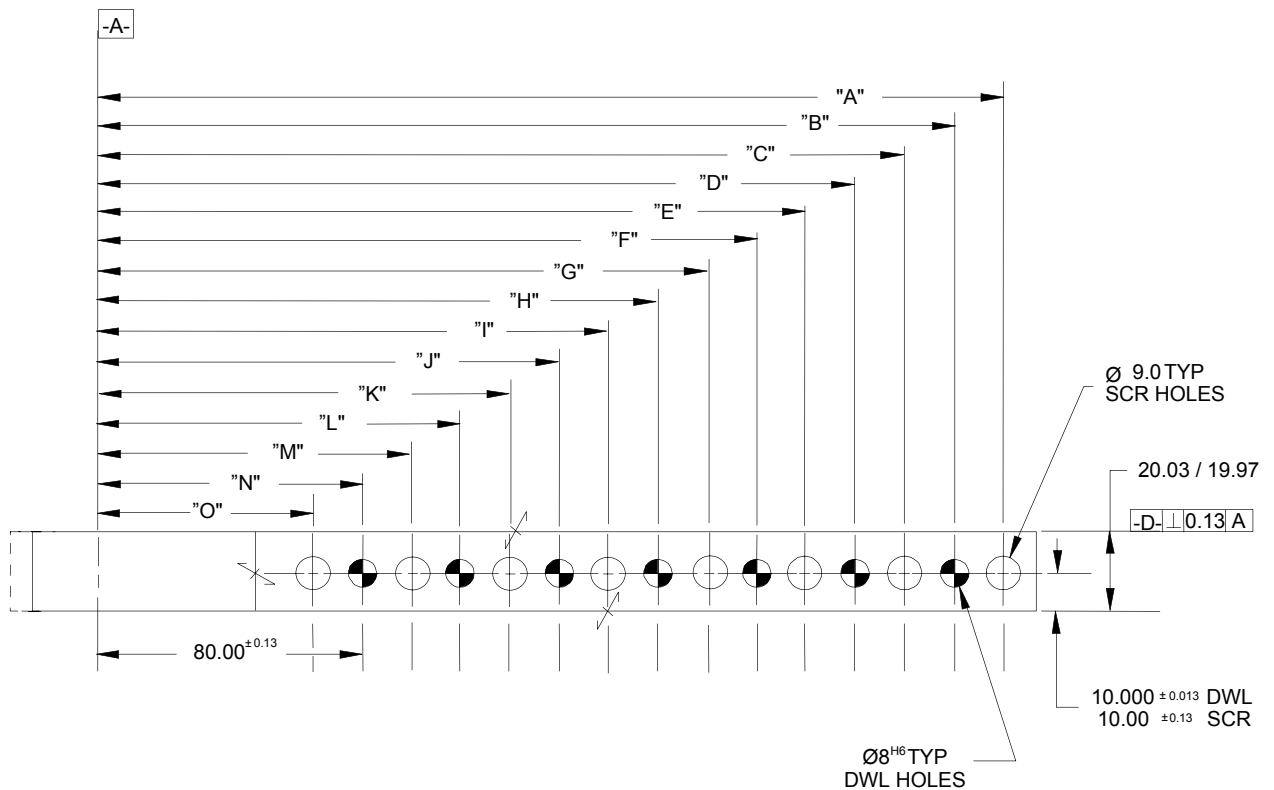
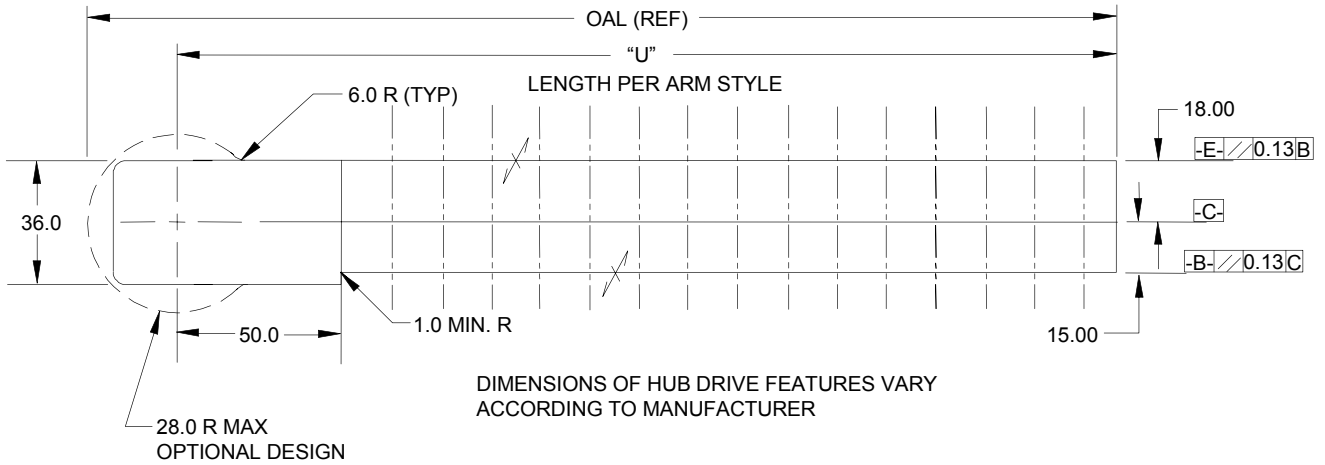

C

B

STAMP OR ETCH THE NAAMS CODE NUMBER AND THE CLAMP ARM MANUFACTURER'S NUMBER, IF DIFFERENT, ON THE SIDE OF THE ARM.

PAINT AS PRESCRIBED ON PAGE G-1.2

TABULATED INFORMATION ON FOLLOWING PAGE

# POWER CLAMP ARMS 60 SERIES

(STRAIGHT - MACHINED) (20mm WIDE)

A

EXCEPT AS NOTED TOLERANCES SHALL BE:

- 1 PLACE MACHINING ±0.3
- 1 PLACE FABRICATION ±1.5
- 2 PLACE ±0.03 GENERAL
  - ±0.03 BETWEEN DOWELS
  - ±0.13 TO SCREW HOLES

NOTES: ALL DIMENSIONS METRIC UNLESS OTHERWISE NOTED.

MATERIAL: SAE 4140 or SAE 1045

NAAMS CODE	DIM "U" +1.5/-0.0	MAX OAL (REF)	Weight kg*	Dim. "A"	Dim. "B"	Dim. "C"	Dim. "D"	Dim. "E"	Dim. "F"	Dim. "G"	Dim. "H"	Dim. "I"	Dim. "J"	Dim. "K"	Dim. "L"	Dim. "M"
ACA513M	135.0	163.0	1.0	125.00	110.00	95.00	80.00	65.00								
ACA514M	165.0	193.0	1.2	155.00	140.00	125.00	110.00	95.00	80.00	65.00						
ACA515M	195.0	223.0	1.3	185.00	170.00	155.00	140.00	125.00	110.00	95.00	80.00	65.00				
ACA516M	225.0	253.0	1.4	215.00	200.00	185.00	170.00	155.00	140.00	125.00	110.00	95.00	80.00	65.00		
ACA517M	255.0	283.0	1.6	245.00	230.00	215.00	200.00	185.00	170.00	155.00	140.00	125.00	110.00	95.00	80.00	65.00
ACA518M	285.0	313.0	1.8	275.00	260.00	245.00	230.00	215.00	200.00	185.00	170.00	155.00	140.00	125.00	110.00	95.00



NAAMS CODE	Dim. "N"	Dim. "O"
ACA518M	80.00	65.00



\* Weight of arm as shown. Actual weight may vary due to variations in mounting details.

SEE DRAWING ON PREVIOUS PAGE

# POWER CLAMP ARMS 60 SERIES

(25mm OFFSET - MACHINED) (20mm WIDE)

Assembly

09/05/12

A

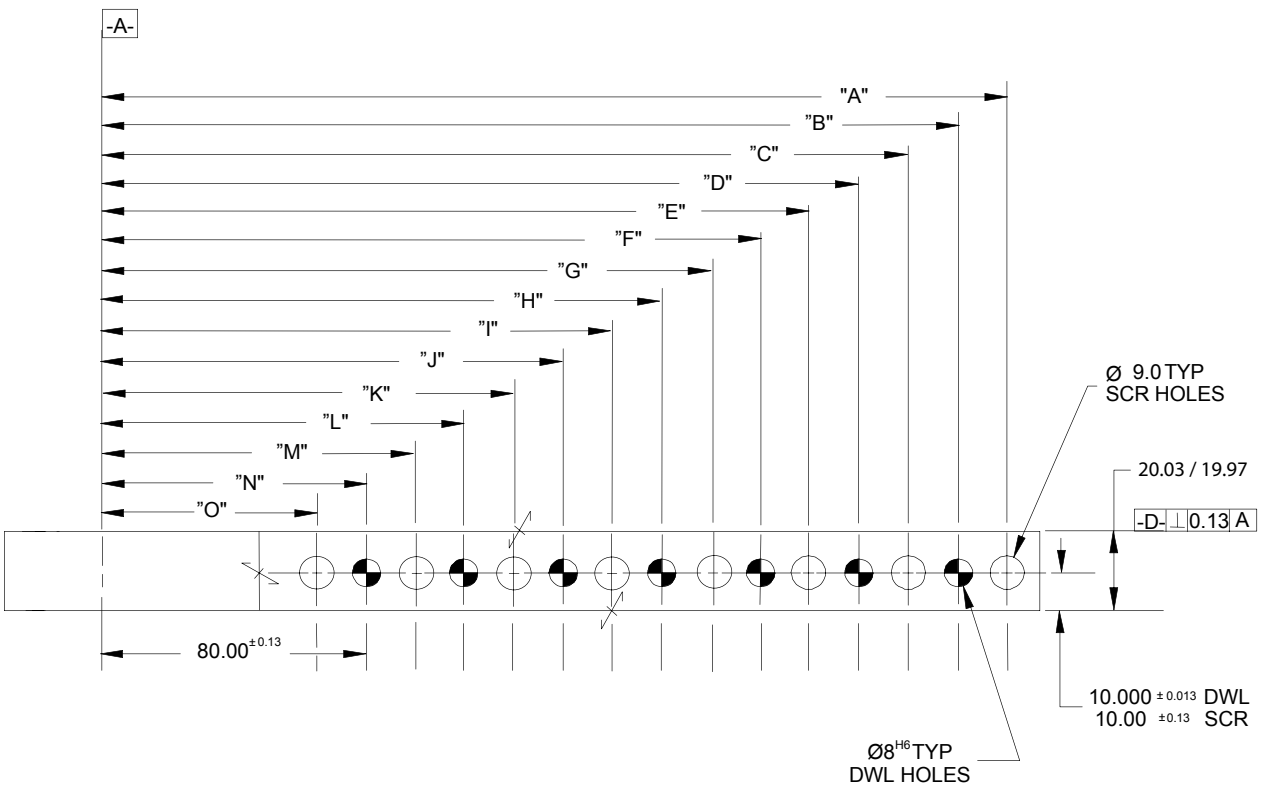
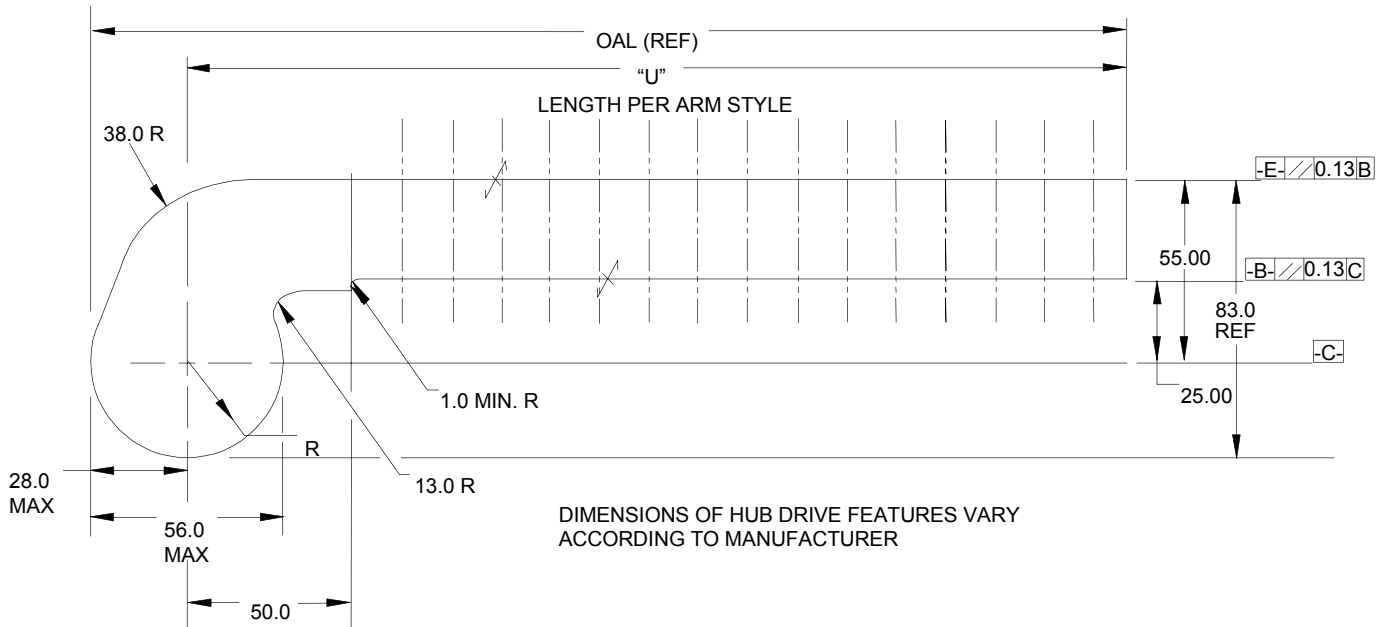

B

C

STAMP OR ETCH THE NAAMS CODE NUMBER AND THE CLAMP ARM MANUFACTURER'S NUMBER, IF DIFFERENT, ON THE SIDE OF THE ARM.

PAINT AS PRESCRIBED ON PAGE G-1.2

TABULATED INFORMATION ON FOLLOWING PAGE

# POWER CLAMP ARMS 60 SERIES

(25mm OFFSET - MACHINED) (20mm WIDE)

GLOBAL STANDARD COMPONENTS



TM

Assembly

11/10/10

A

EXCEPT AS NOTED TOLERANCES SHALL BE:

- 1 PLACE MACHINING  $\pm 0.3$
- 1 PLACE FABRICATION  $\pm 1.5$
- 2 PLACE  $\pm 0.03$  GENERAL
  - $\pm 0.03$  BETWEEN DOWELS
  - $\pm 0.13$  TO SCREW HOLES

NOTES: ALL DIMENSIONS METRIC UNLESS OTHERWISE NOTED.

MATERIAL: SAE 4140 or SAE 1045

NAAMS CODE	DIM "U" +1.5/-0.0	MAX OAL (REF)	Weight kg*	Dim. "A"	Dim. "B"	Dim. "C"	Dim. "D"	Dim. "E"	Dim. "F"	Dim. "G"	Dim. "H"	Dim. "I"	Dim. "J"	Dim. "K"	Dim. "L"	Dim. "M"
ACA525M	135.0	163.0	1.1	125.00	110.00	95.00	80.00	65.00								
ACA526M	165.0	193.0	1.3	155.00	140.00	125.00	110.00	95.00	80.00	65.00						
ACA527M	195.0	223.0	1.4	185.00	170.00	155.00	140.00	125.00	110.00	95.00	80.00	65.00				
ACA528M	225.0	253.0	1.5	215.00	200.00	185.00	170.00	155.00	140.00	125.00	110.00	95.00	80.00	65.00		
ACA529M	255.0	283.0	1.6	245.00	230.00	215.00	200.00	185.00	170.00	155.00	140.00	125.00	110.00	95.00	80.00	65.00
ACA530M	285.0	313.0	1.9	275.00	260.00	245.00	230.00	215.00	200.00	185.00	170.00	155.00	140.00	125.00	110.00	95.00



NAAMS CODE	Dim. "N"	Dim. "O"
ACA530M	80.00	65.00

DOWEL

\* Weight of arm as shown. Actual weight may vary due to variations in mounting details.

SEE DRAWING ON PREVIOUS PAGE

# POWER CLAMP ARMS 60 SERIES

(70mm OFFSET - MACHINED) (20mm WIDE)

Assembly

09/05/12

A

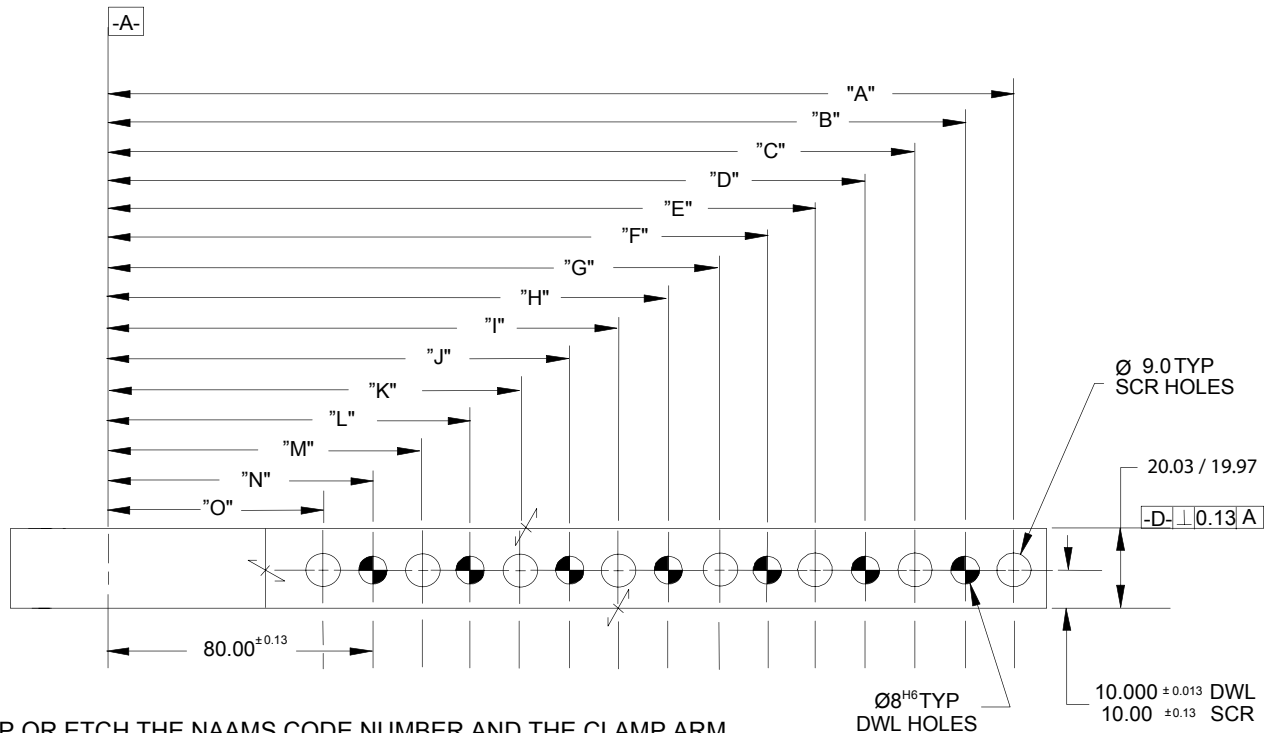
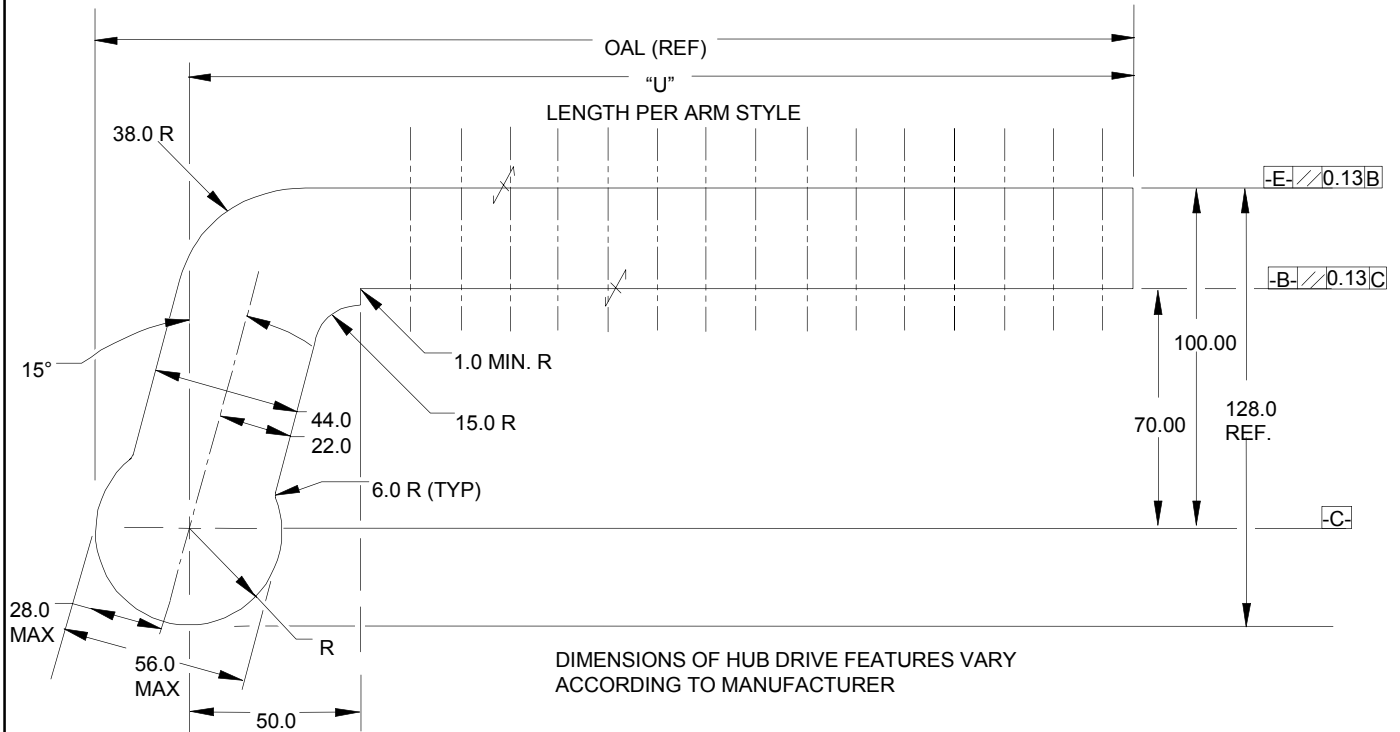

STAMP OR ETCH THE NAAMS CODE NUMBER AND THE CLAMP ARM MANUFACTURER'S NUMBER, IF DIFFERENT, ON THE SIDE OF THE ARM.

PAINT AS PRESCRIBED ON PAGE G-1.2

TABULATED INFORMATION ON FOLLOWING PAGE

C

B

# POWER CLAMP ARMS 60 SERIES

(70mm OFFSET - MACHINED) (20mm WIDE)

GLOBAL STANDARD COMPONENTS



Assembly

11/10/10

A

EXCEPT AS NOTED TOLERANCES SHALL BE:

- 1 PLACE MACHINING  $\pm 0.3$
- 1 PLACE FABRICATION  $\pm 1.5$
- 2 PLACE  $\pm 0.03$  GENERAL
- $\pm 0.03$  BETWEEN DOWELS
- $\pm 0.13$  TO SCREW HOLES

NOTES: ALL DIMENSIONS METRIC UNLESS OTHERWISE NOTED.

MATERIAL: SAE 4140 or SAE 1045

NAAMS CODE	DIM "U" +1.5/-0.0	MAX OAL (REF)	Weight kg*	Dim. "A"	Dim. "B"	Dim. "C"	Dim. "D"	Dim. "E"	Dim. "F"	Dim. "G"	Dim. "H"	Dim. "I"	Dim. "J"	Dim. "K"	Dim. "L"	Dim. "M"
ACA537M	135.0	163.0	1.5	125.00	110.00	95.00	80.00	65.00								
ACA538M	165.0	193.0	1.7	155.00	140.00	125.00	110.00	95.00	80.00	65.00						
ACA539M	195.0	223.0	1.7	185.00	170.00	155.00	140.00	125.00	110.00	95.00	80.00	65.00				
ACA540M	225.0	253.0	1.9	215.00	200.00	185.00	170.00	155.00	140.00	125.00	110.00	95.00	80.00	65.00		
ACA541M	255.0	283.0	2.0	245.00	230.00	215.00	200.00	185.00	170.00	155.00	140.00	125.00	110.00	95.00	80.00	65.00
ACA542M	285.0	313.0	2.2	275.00	260.00	245.00	230.00	215.00	200.00	185.00	170.00	155.00	140.00	125.00	110.00	95.00



NAAMS CODE	Dim. "N"	Dim. "O"
ACA542M	80.00	65.00

DOWEL

\* Weight of arm as shown. Actual weight may vary due to variations in mounting details.

SEE DRAWING ON PREVIOUS PAGE

# POWER CLAMP ARMS 60 SERIES

(120mm OFFSET - MACHINED) (20mm WIDE)

GLOBAL STANDARD COMPONENTS



Assembly

09/05/12

A

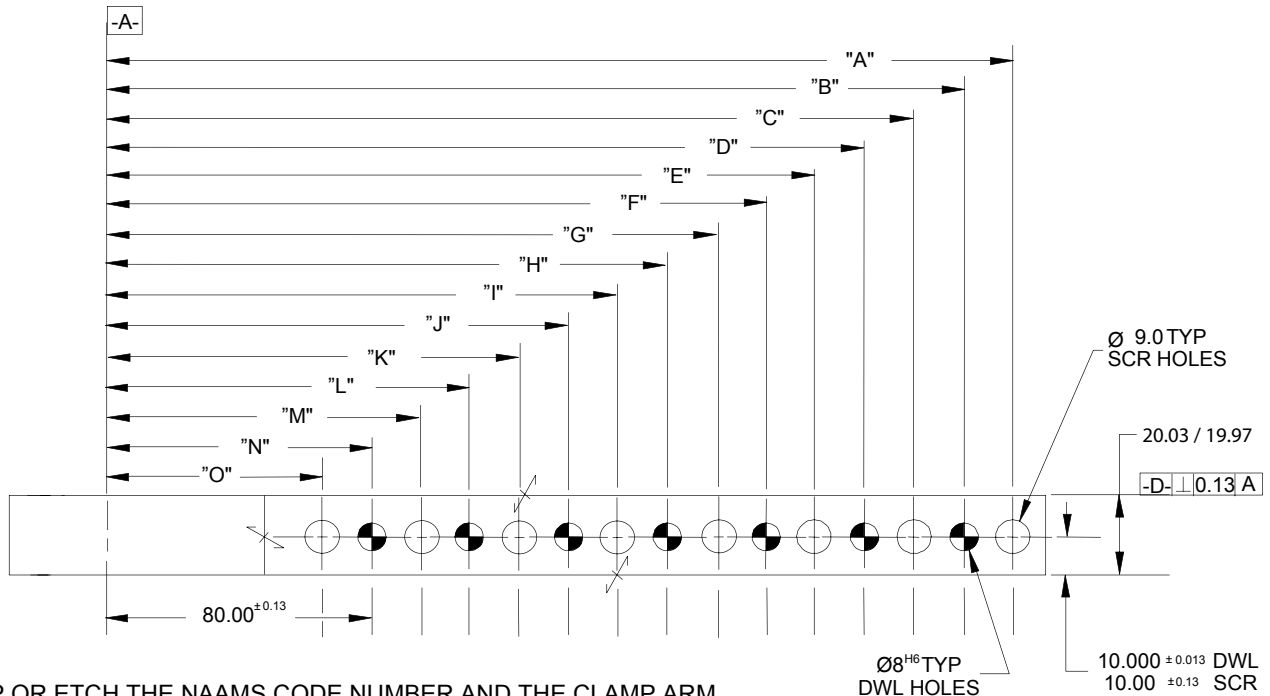
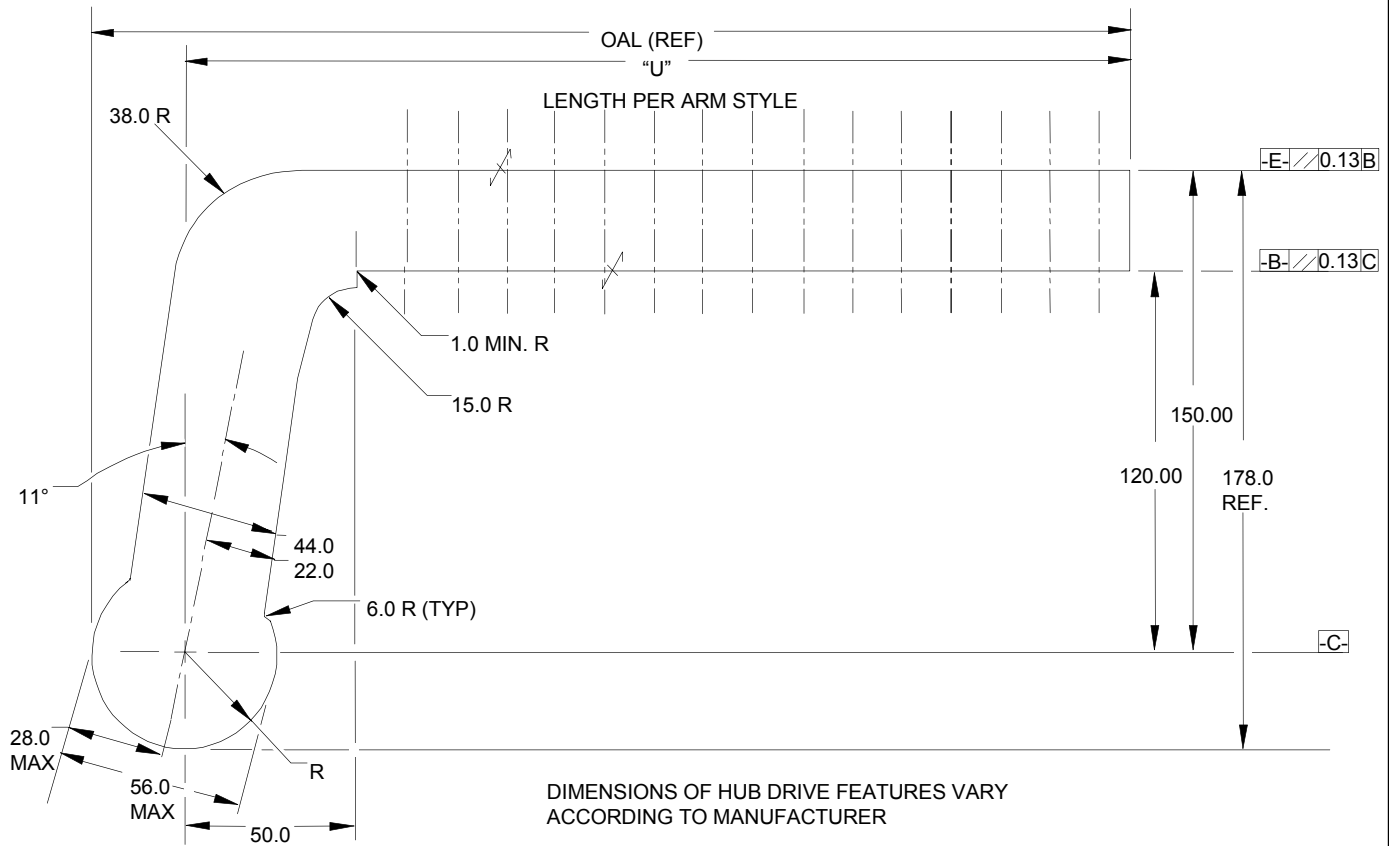

STAMP OR ETCH THE NAAMS CODE NUMBER AND THE CLAMP ARM MANUFACTURER'S NUMBER, IF DIFFERENT, ON THE SIDE OF THE ARM.  
PAINT AS PRESCRIBED ON PAGE G-1.2

TABULATED INFORMATION ON FOLLOWING PAGE

C

B



# POWER CLAMP ARMS 60 SERIES

(120mm OFFSET - MACHINED) (20mm WIDE)

GLOBAL STANDARD COMPONENTS



TM

Assembly

11/10/10

A

EXCEPT AS NOTED TOLERANCES SHALL BE:

- 1 PLACE MACHINING  $\pm 0.3$
- 1 PLACE FABRICATION  $\pm 1.5$
- 2 PLACE  $\pm 0.03$  GENERAL
  - $\pm 0.03$  BETWEEN DOWELS
  - $\pm 0.13$  TO SCREW HOLES

NOTES: ALL DIMENSIONS METRIC UNLESS OTHERWISE NOTED.

MATERIAL: SAE 4140 or SAE 1045

NAAMS CODE	DIM "U" +1.5/-0.0	MAX OAL (REF)	Weight kg*	Dim. "A"	Dim. "B"	Dim. "C"	Dim. "D"	Dim. "E"	Dim. "F"	Dim. "G"	Dim. "H"	Dim. "I"	Dim. "J"	Dim. "K"	Dim. "L"	Dim. "M"
ACA549M	135.0	163.0	1.9	125.00	110.00	95.00	80.00	65.00								
ACA550M	165.0	193.0	2.0	155.00	140.00	125.00	110.00	95.00	80.00	65.00						
ACA551M	195.0	223.0	2.1	185.00	170.00	155.00	140.00	125.00	110.00	95.00	80.00	65.00				
ACA552M	225.0	253.0	2.2	215.00	200.00	185.00	170.00	155.00	140.00	125.00	110.00	95.00	80.00	65.00		
ACA553M	255.0	283.0	2.4	245.00	230.00	215.00	200.00	185.00	170.00	155.00	140.00	125.00	110.00	95.00	80.00	65.00
ACA554M	285.0	313.0	2.6	275.00	260.00	245.00	230.00	215.00	200.00	185.00	170.00	155.00	140.00	125.00	110.00	95.00



NAAMS CODE	Dim. "N"	Dim. "O"
ACA554M	80.00	65.00

DOWEL

\* Weight of arm as shown. Actual weight may vary due to variations in mounting details.

SEE DRAWING ON PREVIOUS PAGE

**POWER CLAMP ARMS**  
**50 SERIES**  
**FOR GRIPPER CLAMPING COMPONENTS**  
**(STRAIGHT - MACHINED) (FULL METRIC)**

GLOBAL STANDARD COMPONENTS



Assembly

04/30/15

A

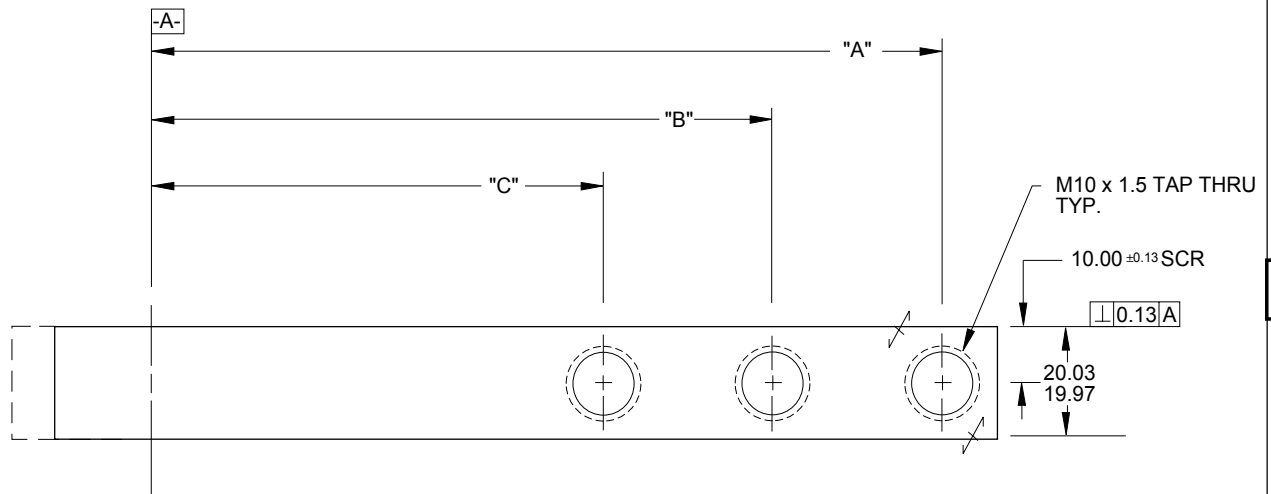
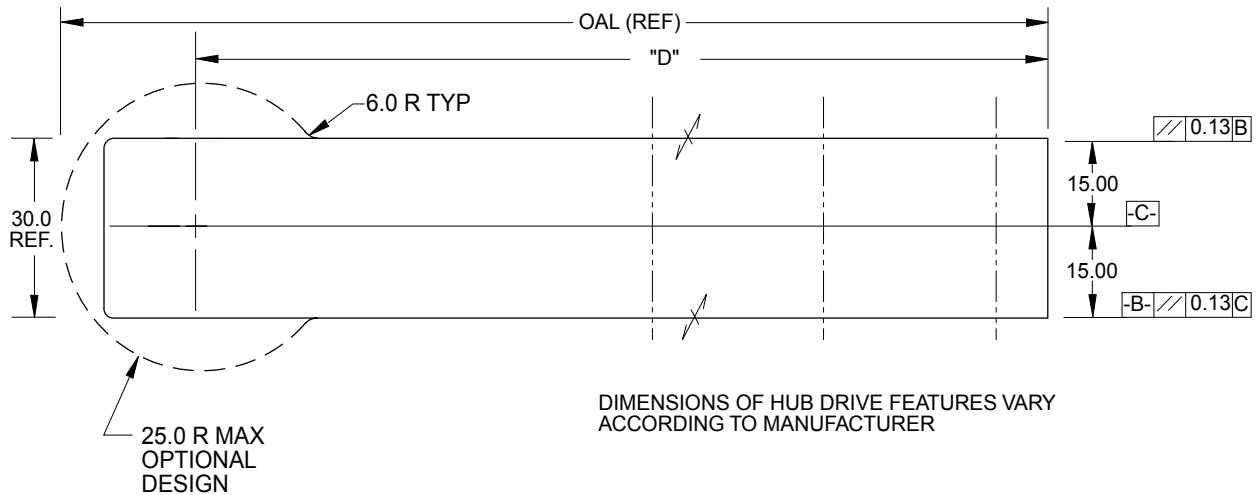

A

EXCEPT AS NOTED TOLERANCES SHALL BE:

- 1 PLACE MACHINING  $\pm 0.3$
- 1 PLACE FABRICATION  $\pm 1.5$
- 2 PLACE  $\pm 0.03$  GENERAL
- $\pm 0.03$  BETWEEN DOWELS
- $\pm 0.13$  TO SCREW HOLES

STAMP OR ETCH THE NAAMS CODE NUMBER AND THE CLAMP ARM MANUFACTURER'S NUMBER, IF DIFFERENT, ON THE SIDE OF THE ARM.

NOTES: ALL DIMENSIONS METRIC UNLESS OTHERWISE NOTED.

PAINT AS PRESCRIBED ON PAGE G-1.4

MATERIAL: SAE 4140 or SAE 1045

NAAMS CODE	DIM. "A"	DIM. "B"	DIM. "C"	DIM. "D" +1.5/-0.0	MAX OAL (REF)	WEIGHT kg
ACA201G	80.00			90.0	115.0	0.4
ACA202G	110.00	80.00		120.0	145.0	0.5
ACA203G	140.00	110.00	80.00	150.0	175.0	0.6

# POWER CLAMP ARMS

## 50 SERIES

### FOR GRIPPER CLAMPING COMPONENTS

(25mm OFFSET - MACHINED) (FULL METRIC)

GLOBAL STANDARD COMPONENTS



Assembly

04/30/15

B

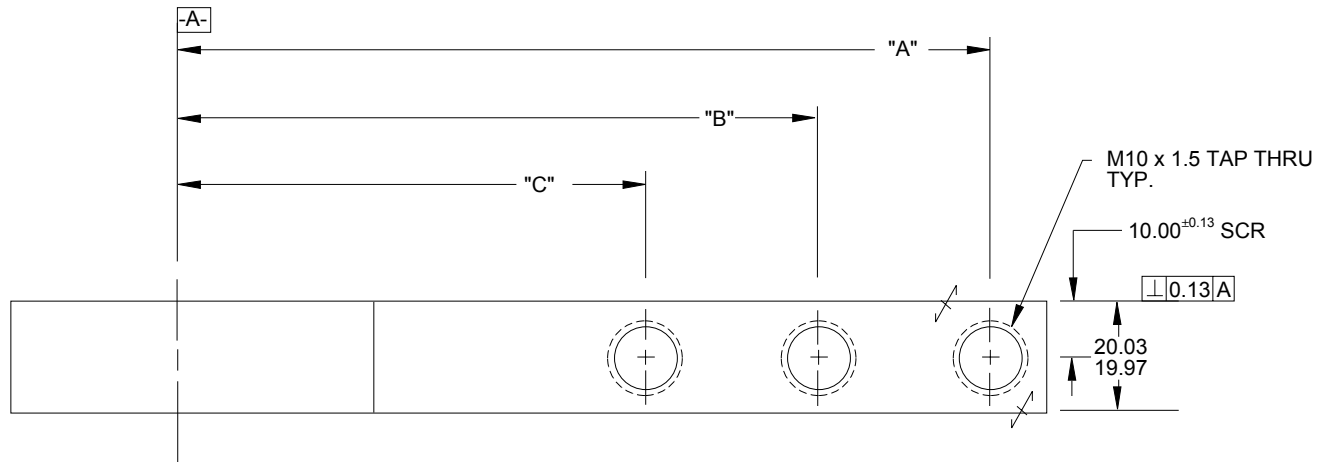
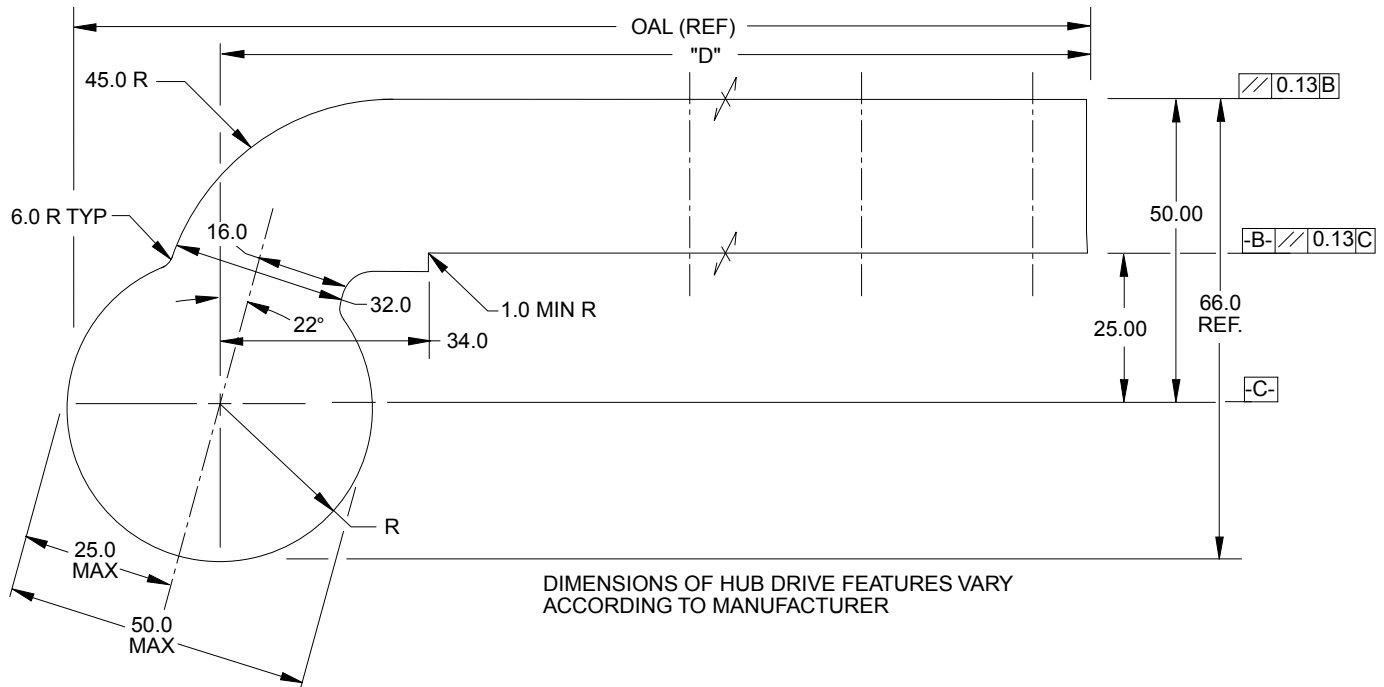

A

EXCEPT AS NOTED TOLERANCES SHALL BE:

- 1 PLACE MACHINING  $\pm 0.3$
- 1 PLACE FABRICATION  $\pm 1.5$
- 2 PLACE  $\pm 0.03$  GENERAL
- $\pm 0.03$  BETWEEN DOWELS
- $\pm 0.13$  TO SCREW HOLES

NOTES: ALL DIMENSIONS METRIC UNLESS OTHERWISE NOTED.  
MATERIAL: SAE 4140 or SAE 1045

STAMP OR ETCH THE NAAMS CODE NUMBER AND  
THE CLAMP ARM MANUFACTURER'S NUMBER, IF  
DIFFERENT, ON THE SIDE OF THE ARM.

PAINT AS PRESCRIBED ON PAGE G-1.4

NAAMS CODE	DIM."A"	DIM."B"	DIM."C"	DIM."D" +1.5/-0.0	MAX OAL (REF)	WEIGHT kg
ACA211G	80.00			90.0	115.0	0.4
ACA212G	110.00	80.00		120.0	145.0	0.5
ACA213G	140.00	110.00	80.00	150.0	175.0	0.6

**POWER CLAMP ARMS**  
**50 SERIES**  
**FOR GRIPPER CLAMPING COMPONENTS**  
**(50mm OFFSET - MACHINED) (FULL METRIC)**

GLOBAL STANDARD COMPONENTS



Assembly

04/30/15

A

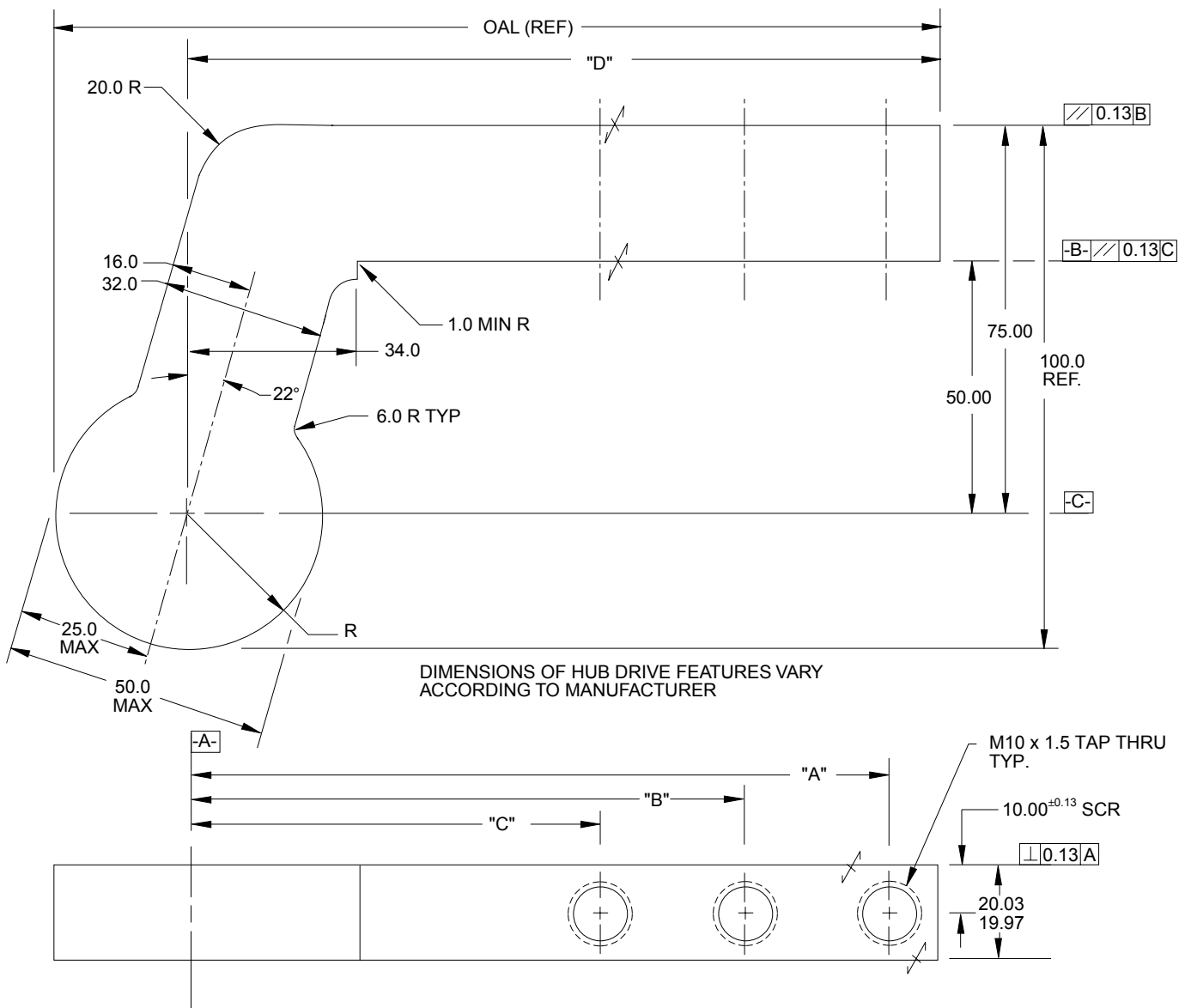

A

EXCEPT AS NOTED TOLERANCES SHALL BE:

- 1 PLACE MACHINING  $\pm 0.3$
- 1 PLACE FABRICATION  $\pm 1.5$
- 2 PLACE  $\pm 0.03$  GENERAL
- $\pm 0.03$  BETWEEN DOWELS
- $\pm 0.13$  TO SCREW HOLES

NOTES: ALL DIMENSIONS METRIC UNLESS OTHERWISE NOTED.

MATERIAL: SAE 4140 or SAE 1045

STAMP OR ETCH THE NAAMS CODE NUMBER AND THE CLAMP ARM MANUFACTURER'S NUMBER, IF DIFFERENT, ON THE SIDE OF THE ARM.

PAIN T AS PRESCRIBED ON PAGE G-1.4

TABULATED INFORMATION ON FOLLOWING PAGE

NAAMS CODE	DIM. "A"	DIM. "B"	DIM. "C"	DIM. "D" +1.5/-0.0	MAX OAL (REF)	WEIGHT kg
ACA221G	80.00			90.0	115.0	0.6
ACA222G	110.00	80.00		120.0	145.0	0.7
ACA223G	140.00	110.00	80.00	150.0	175.0	0.8