

# FASTENER COMPONENTS INDEX

PAGE	DATE	SERIES	DESCRIPTION
<a href="#">F-1</a>	11/10/10		Fastener Component Index
<a href="#">F-1.1</a>	11/10/10		Metric Fastener Standards
<a href="#">F-2</a>	07/25/08		Metric Fastener Standards
<a href="#">F-2.1</a>	05/29/15		Metric Fastener Standards
<a href="#">F-2.2</a>	07/25/08		Preferred Metric Fastener Sizes
<a href="#">F-2.3</a>	08/28/08		Fastener Installation and Torquing Procedures
<a href="#">F-2.4</a>	07/25/08		Torque Audit Procedure
<a href="#">F-2.5</a>	07/25/08		Torque Data Sheet
<a href="#">F-2.6</a>	07/25/08		Fasteners In Non-Ferrous Materials
<a href="#">F-3</a>	07/25/08	F01	Socket Head Cap Screw
<a href="#">F-4</a>	07/25/08	F01	Socket Head Cap Screw Coding (Uncoated)
<a href="#">F-4.1</a>	07/25/08	F01	Socket Head Cap Screw Coding (Uncoated)
<a href="#">F-5</a>	07/25/08	F01	Socket Head Cap Screw Coding (Blue Coated)
<a href="#">F-5.1</a>	07/25/08	F01	Socket Head Cap Screw Coding (Blue Coated)
<a href="#">F-6</a>	07/25/08	F02	Low Profile Socket Head Cap Screw
<a href="#">F-7</a>	07/25/08	F02	Low Profile Socket Head Cap Screw Coding
<a href="#">F-7.1</a>	07/25/08	F02	Low Profile Socket Head Cap Screw Coding
<a href="#">F-8</a>	07/25/08	F03	Socket Flat Head Cap Screw
<a href="#">F-9</a>	07/25/08	F03	Socket Head Cap Screw Coding (Uncoated)
<a href="#">F-9.1</a>	07/25/08	F03	Socket Head Cap Screw Coding (Blue Coated)
<a href="#">F-10</a>	07/25/08	F04	Socket Head Shoulder Screw
<a href="#">F-11</a>	07/25/08	F04	Socket Head Shoulder Screw Coding (Uncoated)
<a href="#">F-11.1</a>	07/25/08	F04	Socket Head Shoulder Screw Coding (Blue Coated)
<a href="#">F-11.2</a>	03/31/10	F05	Hex Head Screw (Class 10.9)
<a href="#">F-11.3</a>	03/31/10	F05	Hex Head Screw (Class 10.9) Coding (Uncoated)
<a href="#">F-11.4</a>	03/31/10	F06	Hex Head Screw (Class 10.9) Coding (Blue Coated)
<a href="#">F-11.5</a>	02/31/10	F05	Hex Head Screw (Class 10.9) Coding (Uncoated)
<a href="#">F-11.6</a>	03/31/10	F06	Hex Head Screw (Class 10.9) Coding (Blue Coated)
<a href="#">F-12</a>	07/25/08	F06	Hex Head Screw (Class 12.9) (Discontinued)
<a href="#">F-12.1</a>	07/25/08	F06	Hex Head Screw (Class 12.9) (Discontinued)
<a href="#">F-13</a>	07/25/08	F06	Hex Head Screw (Class 12.9) Coding (Discontinued)
<a href="#">F-13.1</a>	07/25/08	F06	Hex Head Screw (Class 12.9) Coding (Discontinued)
<a href="#">F-14</a>	05/14/97	F21, F22, F23	Socket Set Screw
<a href="#">F-15</a>	05/14/97	F21, F22, F23	Socket Set Screw Point Styles
<a href="#">F-16</a>	07/25/08	F39	Hex Nut, Fine Thread (F41 Series Discontinued)
<a href="#">F-17</a>	07/25/08	F42	Hex Nut, Coarse Thread Washer Face
<a href="#">F-18</a>	07/25/08	F45, F47	Hex Jam Nut, Fine Thread and Coarse Thread
<a href="#">F-19</a>	07/25/08	F46, F48	Hex Jam Nut, Fine Thread and Coarse Thread with Washer Face
<a href="#">F-20</a>	07/25/08	F62	Hardened Washer
<a href="#">F-21</a>	07/25/08	F91	Pull Dowel Pin
<a href="#">F-22</a>	07/25/08	F91	Pull Dowel Pin Coding
<a href="#">F-23</a>	03/01/99		Preferred Metric Fastener Sizes (Moved to F-2.3)

# METRIC FASTENER STANDARDS

GLOBAL STANDARD COMPONENTS



Assembly

11/10/10

## A Dimensional and Material Specifications

Product	Dimensional Specification	Material Specification
Socket Head Cap Screws	ANSI B18.3.1M	ASTM A574M
Hex Head Cap Screws	ANSI B18.2.3.1M	ASTM F568M, Class 10.9
Base Leveling Screw	M24 x 2.0 x 150 HHCS	Property Class 10.9
Hex Nuts	ANSI B18.2.4.2M	ASTM A563M, Class 12
Lock Nuts	ANSI B18.16.3M	ASTM A563M, Class 12
Hex Jam Nuts	ANSI B18.2.4.5M	ASTM A563M, Class 04
Shoulder Screws	ANSI B18.3.3M	ANSI B18.3.3M
Socket Set Screws	ANSI B18.3.6M	Class 45H
Flat Head Cap Screws	ANSI B18.3.5M	ASTM F835M
Button Head Cap Screws	ANSI B18.3.4M	ASTM F835M
PullOut Dowel Pins	ISO 8735A	—
Flat Washers (M6 – M10) (M12 and Larger)	— ASTM F436M	Rc 38-45 through hardened ASTM F436M

### Notes:

All specifications must be to the latest revision

## B Fastener Installation and Assembly Standards

1. All mating nuts for Property Class 12.9 socket head cap screws must be property class 12, in accordance with ASTM A563M, and conform to ANSI B18.2.4.2M. This requirement is in keeping with ASTM guidelines, which recommend that nuts be strength matched to mating screws.
2. Locking nuts, when specified, must meet requirements of ASTM A563M Class 12, and must be of all metal type, meeting prevailing torque requirements for class 10 nuts in ANSI B18.16.1M.
3. Nylon patch thread locking elements, when specified, should be applied to screw threads, and must meet prevailing torque requirements listed with these standards.
4. The use of anaerobic adhesives should be limited to applications in which installation torque values must be low, and where there is little possibility of fastener re-use. Components that might be serviced or adjusted after they are assembled, including torque auditing by quality control personnel, should not utilize such adhesives.
5. All dowel pins, 6mm and larger in diameter, should be pull type and have an air relief mechanism (machined flat or spiral groove).
6. Dowel pins 5mm and smaller in diameter may be standard or pull type at supplier's option.
7. All washers used in assemblies with screws listed in item 1 must be through hardened.

A  
D

B  
E

C

# METRIC FASTENER STANDARDS

GLOBAL STANDARD COMPONENTS



Assembly

07/25/08

8. Adherence to recommended cutting tools in this standard is mandated in order to achieve proper preloading of fasteners. These standards provide for the maximum allowable eccentricity of the longest standard screws and for certain deviations in the parts being fastened, such as hole straightness, angularity between the axis of the tapped hole and that of the hole for the shank, differences in the center distances of the mating holes and other deviations.

A  
B  
C  
E  
F

D

# METRIC FASTENER STANDARDS

GLOBAL STANDARD COMPONENTS



Assembly

05/29/15

## C Hole Sizes

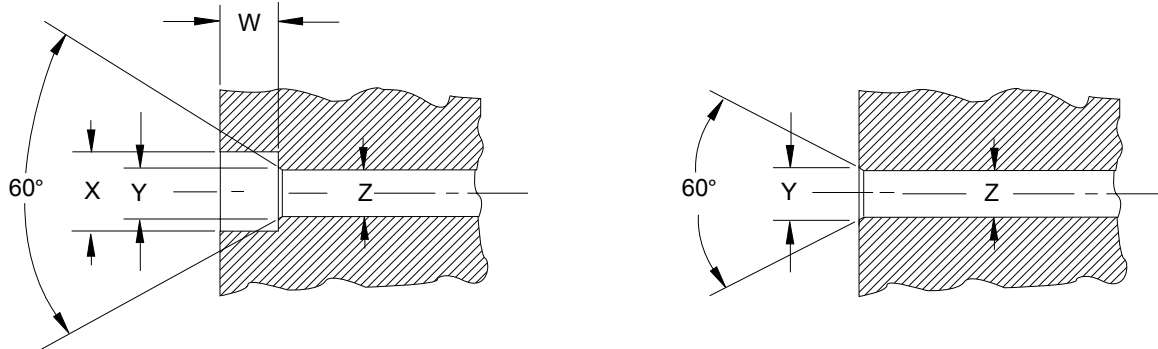

Screw Size	Tap Drill Size (class 6H threads)	X Counterbore Dia.	Y Countersink Dia.	Z Body Drill Size for Counterbore Through Hole	W Counterbore Depth
M3 x 0.5	2.5	6.5	3.6	3.4	5.0
M4 x 0.7	3.3	8.0	4.9	4.5	6.0
M5 x 0.8	4.2	10.0	5.9	5.5	8.0
M6 x 1.0	5.0	11.0	7.1	6.6	9.0
M8 x 1.25	6.7	15.0	9.8	9.0	11.0
M10 x 1.5	8.5	18.0	11.8	11.0	14.0
M12 x 1.75	10.2	20.0	14.7	13.0	16.0
M16 x 2.0	14.0	26.0	18.7	17.0	21.0
M20 x 2.5	17.5	33.0	23.6	21.0	26.0
M24 x 3.0	21.0	40.0	27.6	25.0	32.0

**B**

## D Prevailing Torque requirements for Nylon Patch Screws

Nominal Thread Diameter And Pitch	Clamp Load (kN)	Prevailing Torque Maximum (Nm)	1 <sup>st</sup> Removal Prevailing Torque Minimum (Nm)	5 <sup>th</sup> Removal Prevailing Torque Minimum (Nm)
M6 x 1.0	15.6	3.0	0.45	0.30
M8 x 1.25	28.4	10	0.90	0.58
M10 x 1.5	45.0	14	1.8	1.1
M12 x 1.75	65.4	21	2.6	1.5
M16 x 2.0	122	40	5.0	3.4
M20 x 2.5	190	60	8.0	5.5

**A**

Note: these values are in accordance with IFI 524



# PREFERRED METRIC FASTENER SIZES

## SOCKET HEAD CAP AND HEX HEAD SCREWS

THREAD SIZE & PITCH	CLEARANCE HOLE Ø	PREFERRED LENGTHS								
		16	20	30	40	50	60	70	80	150
M6 X 1*	6.6	X	X	X						
M8 X 1.25*	9.0		X	X	X					
M10 X 1.5*	11.0			X	X	X	X			
M12 X 1.75	13.5			X	X	X	X			
M16 X 2	17.5				X	X	X	X		
M20 X 2.5	22.0					X	X	X	X	
M24 X 2**										X

\*Socket head cap screws only

\*\*Hex head, leveling screw only

## DOWELS (M6) PULL TYPE

DIAMETER	PREFERRED LENGTHS								
	16	20	25	30	35	40	50	60	80
6	X	X	X						
8		X	X	X	X				
10			X	X	X	X			
12				X	X	X	X		
16						X	X	X	
20							X	X	X

B

A

# FASTENER INSTALLATION AND TORQUING PROCEDURE (EXCLUDING SHOULDER SCREWS)

## GENERAL

- This standard applies only to Property Class 10.9 hex head and 12.9 socket head cap screws when used in steel, unlubed and where the head bears against a metal surface. Where the bearing surface is not a metal (e.g. UHMW plastic), the tightening specification for any fastener shall be “snug fit then 1/4 turn”.
- For purposes of uniformity in clamp loading, the calculations for the recommended installation torques listed below are based upon  $K = 0.20$  for uncoated screws and  $K = 0.15$  for blue coated screws.
- Testing by reputable fastener manufacturers has proven that the use of split lockwashers under heads of hardened screws may prevent achieving or retaining the desired preload in bolted joints.

## INSTALLATION PROCEDURE

1. Use only new fasteners for first-time assembly.
2. Before installing the fastener, be sure that it is free of flaws and it is the correct property class. Fasteners with flaws shall be marked with a white line drawn across the threads and discarded.
3. Fasteners may be tightened with any appropriate fastening device. Final torquing shall be done with a calibrated torque wrench to the required value as follows:

Nominal Diameter and Thread Pitch	Recommended Installation Torque (Nm)			
	Uncoated		Coated	
	Property Class 10.9	Property Class 12.9	Property Class 10.9	Property Class 12.9
M6 x 1.0	16	19	12	14
M8 x 1.25	39	45	29	34
M10 x 1.5	76	89	58	68
M12 x 1.75	134	156	100	120
M16 x 2.0	331	387	250	290
M20 x 2.5	644	760	485	570
M24 x 3.0	1120	1308	840	985
M30 x 3.5	2226	2595	1670	1960

4. After torquing is completed, draw a straight line (match mark) from the wall of the fastener head onto the seating surface using a white steel paint pen. Ensure that the line is easily visible for periodic inspection.
5. A fastener suspected of being over-torqued shall be marked as described in item 2 and discarded.
6. Do not torque fasteners at machine break points until final installation.
7. Where safety wiring is specified, do not safety wire any screws until they have passed the torque audit.
8. If fasteners are in a position that a torque wrench cannot be used, the following steps shall be used:
  - a) Tighten the fastener until the joint surfaces have established a snug fit.
  - b) Mark the position of the fastener to the surface with a white steel paint pen.
  - c) Tighten the fastener 1/3 of a turn (120).
  - d) After torquing is completed, draw a straight line (match mark) from the wall of the fastener head onto the seating surface using a white steel paint pen. Ensure that the line is easily visible for periodic inspection.

E  
A  
B  
D  
G

F  
C

# TORQUE AUDIT PROCEDURE

GLOBAL STANDARD COMPONENTS



Assembly

07/25/08

- Applies only to screws installed per the NAAMS Fastener Installation and Torquing Procedure.
  - The method for checking the fastener torque is the Static Torque Method, which is defined as the torque required to start a previously tightened fastener into motion in the direction of tightening.
1. Audit samples shall be a random selection consisting of thirty (30) fasteners from each type/size property class fastener used. Where a sample of thirty is not obtainable, a 100% audit of that type/size/property class fastener is required.
  2. Do not audit at machine break points.
  3. Record the applicable torque values from each of the samples on the NAAMS Torque Data Sheet.
  4. A fastener shall be deemed to have passed the audit if the torque is within the following limits. High and low auditing torque limits are  $\pm 10\%$  of the recommended installation torque.

Nominal Diameter and Thread Pitch	Torque Audit range (Nm)			
	Uncoated		Coated	
	Property Class 10.9	Property Class 12.9	Property Class 10.9	Property Class 12.9
M6 x 1.0	14.4-17.6	16.7-20.5	10.8-13.2	12.6-15.4
M8 x 1.25	35-43	41-50	26-32	31-38
M10 x 1.5	69-84	80-100	52-64	61-74
M12 x 1.75	121-147	140-172	90-110	106-130
M16 x 2.0	300-365	350-425	225-275	260-320
M20 x 2.5	580-710	685-835	435-535	515-630
M24 x 3.0	1010-1230	1180-1440	760-930	890-1090
M30 x 3.5	2000-2450	2340-2860	1500-1840	1760-2160

A

C

B

5. When a fastener fails the audit:
  - a. Due to over-torquing: it shall be marked with a white line drawn across the threads and discarded.
  - b. Due to under-torquing:
    - i) If the fastener is free of flaws it is suitable for re-use.
    - ii) When the fastener is flawed, it shall be marked with a white line drawn across the threads and discarded.
6. When the fastener passes the audit, a straight line (match mark) shall be drawn from the wall of the fastener head onto the seating surface using a green steel paint pen. Ensure that the line is easily visible for periodic inspection.
7. When all of the fasteners in the sample pass the audit, the data sheet shall be marked to so indicate.
8. If one of the fasteners in the audit fails the audit:
  - a. All fasteners of that type/size/property class shall be re-tightened. (Fasteners that passed the audit may be excluded.)
  - b. A new sample shall be selected for re-auditing using the criteria in No. 1. However, fasteners that passed a previous audit shall not be included in the sample for a subsequent audit.
9. Fastener Torque Quality Audit Steps
  - a. Bench Build Audit: Every unit shall pass the audit before it may leave the bench. Multiple units may be combined to achieve the sample size of thirty fasteners.
  - b. Unit-to-Base Audit: Audits shall be performed at periodic stages of the assembly process to ensure that any possible failures are corrected and passing audits are achieved while ensuring accessibility to all fasteners.
  - c. Final Audit: The final audit shall be performed after all engineering changes have been made and all adjustments are complete.

# NAAMS FASTENER INSTALLATION AND TORQUING PROCEDURE

(EXCLUDING SHOULDER SCREWS)

**Torque Data Sheet**  
**Audit Method: Static**  
**(Updated 07/11/08)**

Auditor's name \_\_\_\_\_ Date \_\_\_\_\_

Assembly Plant \_\_\_\_\_ Program/System \_\_\_\_\_

Builder/Leader \_\_\_\_\_ Tool # \_\_\_\_\_

Unit/Station \_\_\_\_\_ Job # \_\_\_\_\_

Audit Type: Bench \_\_\_\_\_ Unit-to-Base \_\_\_\_\_ Final \_\_\_\_\_

Pass / Fail      Uncoated / Blue				Pass / Fail      Uncoated / Blue			
10.9   12.9		M____ sh   hh		10.9   12.9		M____ sh   hh	
Samp. #	Torque Nm	Samp. #	Torque Nm	Samp. #	Torque Nm	Samp. #	Torque Nm
1		16		1		16	
2		17		2		17	
3		18		3		18	
4		19		4		19	
5		20		5		20	
6		21		6		21	
7		22		7		22	
8		23		8		23	
9		24		9		24	
10		25		10		25	
11		26		11		26	
12		27		12		27	
13		28		13		28	
14		29		14		29	
15		30		15		30	

# FASTENERS IN NON-FERROUS MATERIALS

GLOBAL STANDARD COMPONENTS



Assembly

07/25/08

Installation procedure (page F-2.3) and audit procedure (page F-2.4) are applicable.  
Data was developed using uncoated property class 12.9 SHCS.

A

Tapped Material	Thread		F 62 Washer	Torque (Nm)			
	Size	Material		Uncoated		Coated	
				Installation	Audit Range	Installation	Audit Range
Copper C11000	M8	C11000	Yes	31	28-34	23	21-26
		Steel Wire	Yes	37	33-41	28	25-31
	M10	C11000	Yes	47	42-52	35	32-39
		Steel Wire	Yes	56	50-62	42	38-46
Copper C18000	M8	C18000	No	34	31-37	26	23-28
		C18000	Yes	37	33-41	28	25-31
	M10	C18000	No	54	49-59	41	37-45
		C18000	Yes	56	50-62	42	38-46
Stainless Steel S304	M8	S304	No	39	35-43	29	26-32
		S304	Yes	37	33-41	28	25-31
	M10	S304	No	66	59-73	50	45-55
		S304	Yes	56	50-62	42	38-46
Aluminum 6061-T6	M8	6060-T6	Yes	37	33-41	28	25-31
		Steel Wire	Yes	37	33-41	28	25-31
	M10	6060-T6	Yes	56	50-62	42	38-46
		Steel Wire	Yes	56	50-62	42	38-46

# SOCKET HEAD CAP SCREW

(F01 SERIES)

GLOBAL STANDARD COMPONENTS

# NAAMS



Assembly

07/25/08

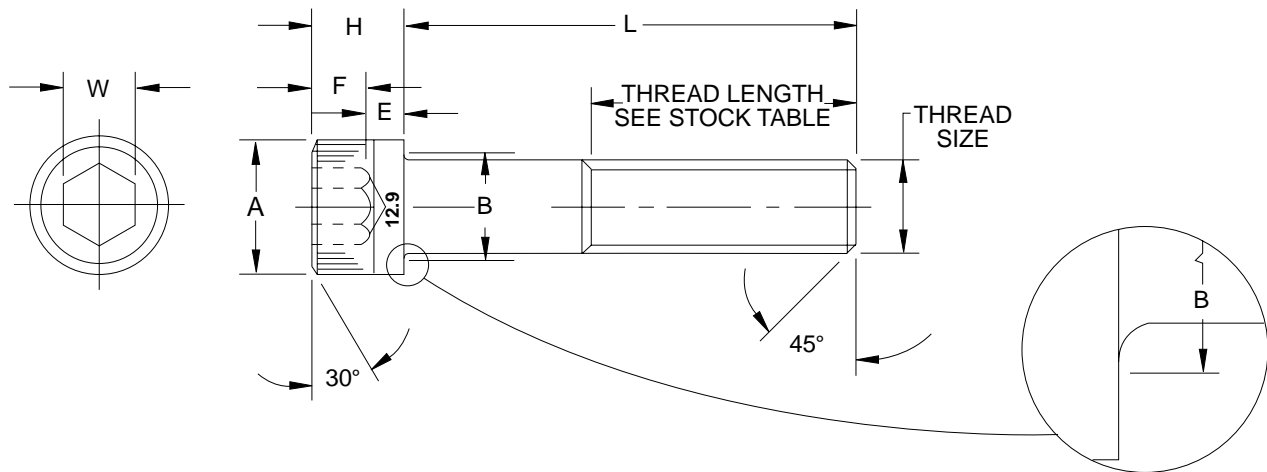

DIMENSIONS							
THREAD SIZE NOM.	PITCH	A MAX.	B MAX.	H MAX.	W NOM.	E MIN.	F MIN.
M3	0.5	5.5	3.6	3.0	2.5	1.02	1.5
M4	0.7	7.0	4.7	4.0	3.0	1.52	2.0
M5	0.8	8.5	5.7	5.0	4.0	1.90	2.5
M6	1.0	10.0	6.8	6.0	5.0	2.28	3.0
M8	1.25	13.0	9.2	8.0	6.0	3.2	4.0
M10	1.5	16.0	11.2	10.0	8.0	4.0	5.0
M12	1.75	18.0	14.2	12.0	10.0	4.8	6.0
M16	2.0	24.0	18.2	16.0	14.0	6.4	8.0
M20	2.5	30.0	22.4	20.0	17.0	8.0	10.0
M24	3.0	36.0	26.4	24.0	19.0	9.6	12.0

\* For hole dimensions see p F-2.1

### NOTES & SPECIFICATIONS:

Material, class 12.9  
ANSI B18.3.1M  
ASTM A574M

CODING ON FOLLOWING PAGE

D

B

C

A

E



# SOCKET HEAD CAP SCREW CODING

(UNCOATED)  
(F01 SERIES)

GLOBAL STANDARD COMPONENTS



Assembly

07/25/08

B

NAAMS CODE	NOM. SIZE, PITCH AND LENGTH
F011011	M10x1.5x25
F011012	M10x1.5x30
F011013	M10x1.5x35
F011014	M10x1.5x40
F011015	M10x1.5x45
F011016	M10x1.5x50
F011017	M10x1.5x55
F011018	M10x1.5x60
F011019	M10x1.5x65
F011020	M10x1.5x70
F011021	M10x1.5x75
F011022	M10x1.5x80
F011023	M10x1.5x90
F011024	M10x1.5x100
F011025	M10x1.5x110
F011026	M10x1.5x120
F011027	M10x1.5x130
F011028	M10x1.5x140
F011029	M10x1.5x150
F011030	M10x1.5x160
F011031	M10x1.5x170
F011032	M10x1.5x180
F011033	M10x1.5x190
F011034	M10x1.5x200
F011208	M12x1.75x12
F011209	M12x1.75x16
F011210	M12x1.75x20
F011211	M12x1.75x25
F011212	M12x1.75x30
F011213	M12x1.75x35
F011214	M12x1.75x40
F011215	M12x1.75x45
F011216	M12x1.75x50
F011217	M12x1.75x55
F011218	M12x1.75x60
F011219	M12x1.75x65
F011220	M12x1.75x70
F011221	M12x1.75x75
F011222	M12x1.75x80
F011223	M12x1.75x90

NAAMS CODE	NOM. SIZE, PITCH AND LENGTH
F011224	M12x1.75x100
F011225	M12x1.75x110
F011226	M12x1.75x120
F011227	M12x1.75x130
F011228	M12x1.75x140
F011229	M12x1.75x150
F011230	M12x1.75x160
F011231	M12x1.75x170
F011232	M12x1.75x180
F011233	M12x1.75x190
F011234	M12x1.75x200
F011613	M16x2.0x35
F011614	M16x2.0x40
F011615	M16x2.0x45
F011616	M16x2.0x50
F011617	M16x2.0x55
F011618	M16x2.0x60
F011619	M16x2.0x65
F011620	M16x2.0x70
F011621	M16x2.0x75
F011622	M16x2.0x80
F011623	M16x2.0x90
F011624	M16x2.0x100
F011625	M16x2.0x110
F011626	M16x2.0x120
F011627	M16x2.0x130
F011628	M16x2.0x140
F011629	M16x2.0x150
F011630	M16x2.0x160
F011631	M16x2.0x170
F011632	M16x2.0x180
F011633	M16x2.0x190
F011634	M16x2.0x200
F012013	M20x2.5x35
F012014	M20x2.5x40
F012015	M20x2.5x45
F012016	M20x2.5x50
F012017	M20x2.5x55
F012018	M20x2.5x60
F012 019	M20x2.5x65

NAAMS CODE	NOM. SIZE, PITCH AND LENGTH
F012020	M20x2.5x70
F012021	M20x2.5x75
F012022	M20x2.5x80
F012023	M20x2.5x90
F012024	M20x2.5x100
F012025	M20x2.5x110
F012026	M20x2.5x120
F012027	M20x2.5x130
F012028	M20x2.5x140
F012029	M20x2.5x150
F012030	M20x2.5x160
F012031	M20x2.5x170
F012032	M20x2.5x180
F012033	M20x2.5x190
F012034	M20x2.5x200
F012415	M24x3.0x45
F012416	M24x3.0x50
F012417	M24x3.0x55
F012418	M24x3.0x60
F012419	M24x3.0x65
F012420	M24x3.0x70
F012421	M24x3.0x75
F012422	M24x3.0x80
F012423	M24x3.0x90
F012424	M24x3.0x100
F012425	M24x3.0x110
F012426	M24x3.0x120
F012427	M24x3.0x130
F012428	M24x3.0x140
F012429	M24x3.0x150
F012430	M24x3.0x160
F012431	M24x3.0x170
F012432	M24x3.0x180
F012433	M24x3.0x190
F012434	M24x3.0x200

A





# SOCKET HEAD CAP SCREW CODING

(BLUE COATED)  
(F01 SERIES)

GLOBAL STANDARD COMPONENTS



Assembly

07/25/08

A

NAAMS CODE	NOM. SIZE, PITCH AND LENGTH
F011011B	M10x1.5x25
F011012B	M10x1.5x30
F011013B	M10x1.5x35
F011014B	M10x1.5x40
F011015B	M10x1.5x45
F011016B	M10x1.5x50
F011017B	M10x1.5x55
F011018B	M10x1.5x60
F011019B	M10x1.5x65
F011020B	M10x1.5x70
F011021B	M10x1.5x75
F011022B	M10x1.5x80
F011023B	M10x1.5x90
F011024B	M10x1.5x100
F011025B	M10x1.5x110
F011026B	M10x1.5x120
F011027B	M10x1.5x130
F011028B	M10x1.5x140
F011029B	M10x1.5x150
F011030B	M10x1.5x160
F011031B	M10x1.5x170
F011032B	M10x1.5x180
F011033B	M10x1.5x190
F011034B	M10x1.5x200
F011208B	M12x1.75x12
F011209B	M12x1.75x16
F011210B	M12x1.75x20
F011211B	M12x1.75x25
F011212B	M12x1.75x30
F011213B	M12x1.75x35
F011214B	M12x1.75x40
F011215B	M12x1.75x45
F011216B	M12x1.75x50
F011217B	M12x1.75x55
F011218B	M12x1.75x60
F011219B	M12x1.75x65
F011220B	M12x1.75x70
F011221B	M12x1.75x75
F011222B	M12x1.75x80
F011223B	M12x1.75x90

NAAMS CODE	NOM. SIZE, PITCH AND LENGTH
F011224B	M12x1.75x100
F011225B	M12x1.75x110
F011226B	M12x1.75x120
F011227B	M12x1.75x130
F011228B	M12x1.75x140
F011229B	M12x1.75x150
F011230B	M12x1.75x160
F011231B	M12x1.75x170
F011232B	M12x1.75x180
F011233B	M12x1.75x190
F011234B	M12x1.75x200
F011613B	M16x2.0x35
F011614B	M16x2.0x40
F011615B	M16x2.0x45
F011616B	M16x2.0x50
F011617B	M16x2.0x55
F011618B	M16x2.0x60
F011619B	M16x2.0x65
F011620B	M16x2.0x70
F011621B	M16x2.0x75
F011622B	M16x2.0x80
F011623B	M16x2.0x90
F011624B	M16x2.0x100
F011625B	M16x2.0x110
F011626B	M16x2.0x120
F011627B	M16x2.0x130
F011628B	M16x2.0x140
F011629B	M16x2.0x150
F011630B	M16x2.0x160
F011631B	M16x2.0x170
F011632B	M16x2.0x180
F011633B	M16x2.0x190
F011634B	M16x2.0x200
F012013B	M20x2.5x35
F012014B	M20x2.5x40
F012015B	M20x2.5x45
F012016B	M20x2.5x50
F012017B	M20x2.5x55
F012018B	M20x2.5x60
F012 019B	M20x2.5x65

NAAMS CODE	NOM. SIZE, PITCH AND LENGTH
F012020B	M20x2.5x70
F012021B	M20x2.5x75
F012022B	M20x2.5x80
F012023B	M20x2.5x90
F012024B	M20x2.5x100
F012025B	M20x2.5x110
F012026B	M20x2.5x120
F012027B	M20x2.5x130
F012028B	M20x2.5x140
F012029B	M20x2.5x150
F012030B	M20x2.5x160
F012031B	M20x2.5x170
F012032B	M20x2.5x180
F012033B	M20x2.5x190
F012034B	M20x2.5x200
F012415B	M24x3.0x45
F012416B	M24x3.0x50
F012417B	M24x3.0x55
F012418B	M24x3.0x60
F012419B	M24x3.0x65
F012420B	M24x3.0x70
F012421B	M24x3.0x75
F012422B	M24x3.0x80
F012423B	M24x3.0x90
F012424B	M24x3.0x100
F012425B	M24x3.0x110
F012426B	M24x3.0x120
F012427B	M24x3.0x130
F012428B	M24x3.0x140
F012429B	M24x3.0x150
F012430B	M24x3.0x160
F012431B	M24x3.0x170
F012432B	M24x3.0x180
F012433B	M24x3.0x190
F012434B	M24x3.0x200

# LOW PROFILE SOCKET HEAD CAP SCREW

(F02 SERIES)

GLOBAL STANDARD COMPONENTS



Assembly

07/25/08

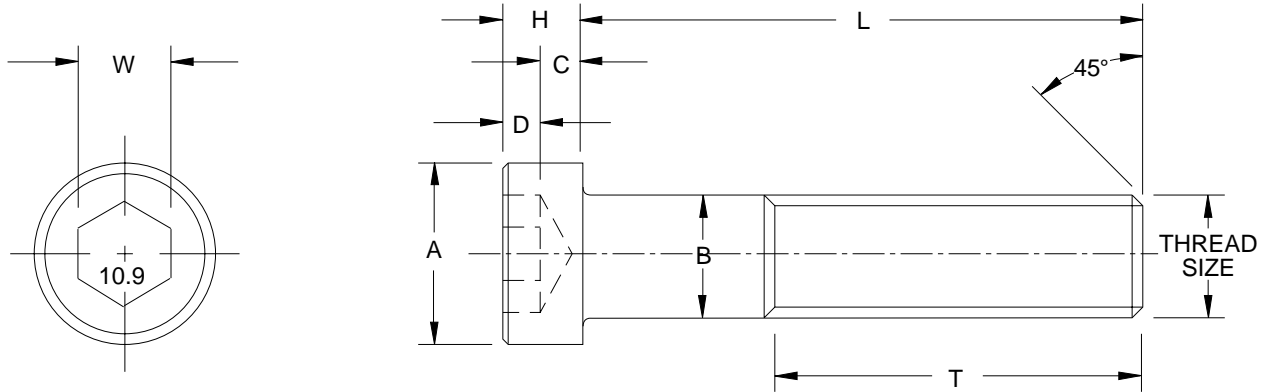

DIMENSIONS								
NOM. THREAD SIZE	PITCH	A	B	C	D	H	T	W
		MAX	MAX	MIN	MIN	MAX	MIN	NOM
M4	0.7	7.0	4	1.06	1.48	2.8	20	3
M5	0.8	8.5	5	1.39	1.85	3.5	22	4
M6	1.0	10.0	6	1.65	2.09	4.0	24	5
M8	1.25	13.0	8	2.24	2.48	5.0	28	6
M10	1.5	16.0	10	2.86	3.36	6.5	32	8
M12	1.75	18.0	12	3.46	4.26	8.0	36	10
M16	2.0	24.0	16	4.91	4.76	10.0	44	12
M20	2.5	30.0	20	6.10	6.07	12.5	52	14

THREAD SIZE NOM.	STOCK SIZES (L)																		
	8	10	12	16	20	25	30	35	40	45	50	55	60	70	80	90	100	110	120
M4	█	█	█	█	█	█	█	█	█	█	█	█	█	█	█	█	█	█	█
M5	█	█	█	█	█	█	█	█	█	█	█	█	█	█	█	█	█	█	█
M6	█	█	█	█	█	█	█	█	█	█	█	█	█	█	█	█	█	█	█
M8	█	█	█	█	█	█	█	█	█	█	█	█	█	█	█	█	█	█	█
M10	█	█	█	█	█	█	█	█	█	█	█	█	█	█	█	█	█	█	█
M12	█	█	█	█	█	█	█	█	█	█	█	█	█	█	█	█	█	█	█
M16	█	█	█	█	█	█	█	█	█	█	█	█	█	█	█	█	█	█	█
M20	█	█	█	█	█	█	█	█	█	█	█	█	█	█	█	█	█	█	█

- Lengths to the left of heavy line (█) threaded to head.
- Lengths to the right of heavy line (█) have standard minimum thread lengths of two times the nominal thread diameter plus 12 mm.

**NOTES & SPECIFICATIONS:**

Material, class 10.9

CODING ON FOLLOWING PAGE

B

C

A

D

# LOW PROFILE SOCKET HEAD CAP SCREW CODING

(UNCOATED)  
(F02 SERIES)

GLOBAL STANDARD COMPONENTS

TM **NAAMS** 

Assembly

07/25/08

A

NAAMS CODE	NOM. SIZE, PITCH AND LENGTH
F020406	M4x0.7x8
F020407	M4x0.7x10
F020408	M4x0.7x12
F020409	M4x0.7x16
F020410	M4x0.7x20
F020411	M4x0.7x25
F020412	M4x0.7x30
F020506	M5x0.8x8
F020507	M5x0.8x10
F020508	M5x0.8x12
F020509	M5x0.8x16
F020510	M5x0.8x20
F020511	M5x0.8x25
F020512	M5x0.8x30
F020513	M5x0.8x35
F020514	M5x0.8x40
F020606	M6x1.0x8
F020607	M6x1.0x10
F020608	M6x1.0x12
F020609	M6x1.0x16
F020610	M6x1.0x20
F020611	M6x1.0x25
F020612	M6x1.0x30
F020613	M6x1.0x35
F020614	M6x1.0x40
F020615	M6x1.0x45
F020616	M6x1.0x50
F020617	M6x1.0.55
F020618	M6x1.0x60
F020808	M8x1.25x12
F020809	M8x1.25x16

NAAMS CODE	NOM. SIZE, PITCH AND LENGTH
F020810	M8x1.25x20
F020811	M8x1.25x25
F020812	M8x1.25x30
F020813	M8x1.25x35
F020814	M8x1.25x40
F020815	M8x1.25x45
F020816	M8x1.25x50
F020817	M8x1.25.55
F020818	M8x1.25x60
F020820	M8x1.25x70
F021009	M10x1.5x16
F021010	M10x1.5x20
F021011	M10x1.5x25
F021012	M10x1.5x30
F021013	M10x1.5x35
F021014	M10x1.5x40
F021015	M10x1.5x45
F021016	M10x1.5x50
F021017	M10x1.5x55
F021018	M10x1.5x60
F021020	M10x1.5x70
F021022	M10x1.5x80
F021023	M10x1.5x90
F021024	M10x1.5x100
F021210	M12x1.75x20
F021211	M12x1.75x25
F021212	M12x1.75x30
F021213	M12x1.75x35
F021214	M12x1.75x40
F021215	M12x1.75x45
F021216	M12x1.75x50

NAAMS CODE	NOM. SIZE, PITCH AND LENGTH
F021217	M12x1.75x55
F021218	M12x1.75x60
F021220	M12x1.75x70
F021222	M12x1.75x80
F021223	M12x1.75x90
F021224	M12x1.75x100
F021612	M16x2.0x30
F021613	M16x2.0x35
F021614	M16x2.0x40
F021615	M16x2.0x45
F021616	M16x2.0x50
F021617	M16x2.0x55
F021618	M16x2.0x60
F021620	M16x2.0x70
F021622	M16x2.0x80
F021623	M16x2.0x90
F021624	M16x2.0x100
F021625	M16x2.0x110
F021626	M16x2.0x120
F022014	M20x2.5x40
F022015	M20x2.5x45
F022016	M20x2.5x50
F022017	M20x2.5x55
F022018	M20x2.5x60
F022020	M20x2.5x70
F022022	M20x2.5x80
F022023	M20x2.5x90
F022024	M20x2.5x100
F022025	M20x2.5x110
F022026	M20x2.5x120

# LOW PROFILE SOCKET HEAD CAP SCREW CODING

(BLUE COATED)  
(F02 SERIES)

GLOBAL STANDARD COMPONENTS

TM **NAAMS** 

Assembly

07/25/08

A

NAAMS CODE	NOM. SIZE, PITCH AND LENGTH
F020406B	M4x0.7x8
F020407B	M4x0.7x10
F020408B	M4x0.7x12
F020409B	M4x0.7x16
F020410B	M4x0.7x20
F020411B	M4x0.7x25
F020412B	M4x0.7x30
F020506B	M5x0.8x8
F020507B	M5x0.8x10
F020508B	M5x0.8x12
F020509B	M5x0.8x16
F020510B	M5x0.8x20
F020511B	M5x0.8x25
F020512B	M5x0.8x30
F020513B	M5x0.8x35
F020514B	M5x0.8x40
F020606B	M6x1.0x8
F020607B	M6x1.0x10
F020608B	M6x1.0x12
F020609B	M6x1.0x16
F020610B	M6x1.0x20
F020611B	M6x1.0x25
F020612B	M6x1.0x30
F020613B	M6x1.0x35
F020614B	M6x1.0x40
F020615B	M6x1.0x45
F020616B	M6x1.0x50
F020617B	M6x1.0.55
F020618B	M6x1.0x60
F020808B	M8x1.25x12
F020809B	M8x1.25x16

NAAMS CODE	NOM. SIZE, PITCH AND LENGTH
F020810B	M8x1.25x20
F020811B	M8x1.25x25
F020812B	M8x1.25x30
F020813B	M8x1.25x35
F020814B	M8x1.25x40
F020815B	M8x1.25x45
F020816B	M8x1.25x50
F020817B	M8x1.25.55
F020818B	M8x1.25x60
F020820B	M8x1.25x70
F021009B	M10x1.5x16
F021010B	M10x1.5x20
F021011B	M10x1.5x25
F021012B	M10x1.5x30
F021013B	M10x1.5x35
F021014B	M10x1.5x40
F021015B	M10x1.5x45
F021016B	M10x1.5x50
F021017B	M10x1.5x55
F021018B	M10x1.5x60
F021020B	M10x1.5x70
F021022B	M10x1.5x80
F021023B	M10x1.5x90
F021024B	M10x1.5x100
F021210B	M12x1.75x20
F021211B	M12x1.75x25
F021212B	M12x1.75x30
F021213B	M12x1.75x35
F021214B	M12x1.75x40
F021215B	M12x1.75x45
F021216B	M12x1.75x50

NAAMS CODE	NOM. SIZE, PITCH AND LENGTH
F021217B	M12x1.75x55
F021218B	M12x1.75x60
F021220B	M12x1.75x70
F021222B	M12x1.75x80
F021223B	M12x1.75x90
F021224B	M12x1.75x100
F021612B	M16x2.0x30
F021613B	M16x2.0x35
F021614B	M16x2.0x40
F021615B	M16x2.0x45
F021616B	M16x2.0x50
F021617B	M16x2.0x55
F021618B	M16x2.0x60
F021620B	M16x2.0x70
F021622B	M16x2.0x80
F021623B	M16x2.0x90
F021624B	M16x2.0x100
F021625B	M16x2.0x110
F021626B	M16x2.0x120
F022014B	M20x2.5x40
F022015B	M20x2.5x45
F022016B	M20x2.5x50
F022017B	M20x2.5x55
F022018B	M20x2.5x60
F022020B	M20x2.5x70
F022022B	M20x2.5x80
F022023B	M20x2.5x90
F022024B	M20x2.5x100
F022025B	M20x2.5x110
F022026B	M20x2.5x120

# SOCKET FLATHEAD CAP SCREW

(F03 SERIES)

GLOBAL STANDARD COMPONENTS

# NAAMS



Assembly

07/25/08

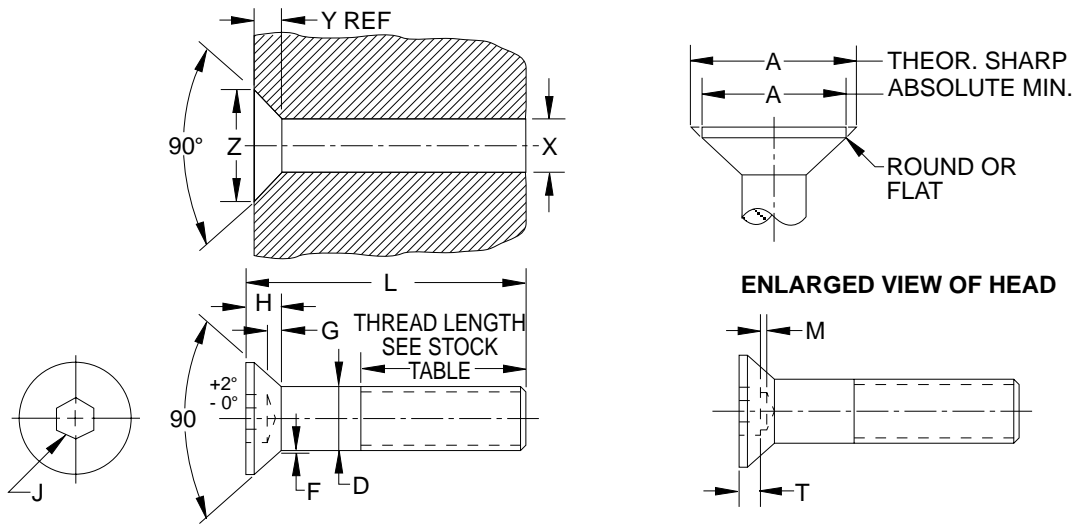

NOM. SCR. DIA. AND THREAD PITCH	D BODY DIAMETER		A HEAD DIA.		H HEAD HGT.		J	T	G	F	M
	MAX	MIN	THEOR. SHARP MAX	ABS. MIN	REF	FLUSHNESS TOL.	HEX. SOC. SIZE NOM	KEY ENGAGEMENT MIN	WALL THK. MIN	FILLET EXT. ABOVE D MAX	DRILL ALLOWANCE MAX
M3 x 0.5	3.00	2.86	6.72	5.35	1.86	0.30	2.0	1.1	0.25	0.25	0.3
M4 x 0.7	4.00	3.82	8.96	7.80	2.48	0.30	2.5	1.5	0.45	0.35	0.4
M5 x 0.8	5.00	4.82	11.20	9.75	3.10	0.35	3.0	1.9	0.66	0.40	0.5
M6 x 1	6.00	5.82	13.44	11.70	3.72	0.35	4.0	2.2	0.70	0.50	0.6
M8 x 1.25	8.00	7.78	17.92	15.65	4.96	0.40	5.0	3.0	1.16	0.60	0.8
M10 x 1.5	10.00	9.78	22.40	19.50	6.20	0.50	6.0	3.6	1.62	0.80	0.9
M12 x 1.75	12.00	11.73	26.88	23.40	7.44	0.60	8.0	4.3	1.80	0.90	1.2
M16 x 2	16.00	15.73	33.60	23.76	8.80	0.80	10.0	4.8	2.20	1.00	1.5
M20 x 2.5	20.00	19.67	40.32	34.60	10.16	1.00	12.0	5.6	2.20	1.20	1.5

THREAD SIZE NOM.	STOCK SIZES (L)																	
	6	8	10	12	16	20	25	30	35	40	45	50	55	60	70	80	90	100
M3	█	█	█	█	█	█	█	█	█	█	█	█	█	█	█	█	█	█
M4		█	█	█	█	█	█	█	█	█	█	█	█	█	█	█	█	█
M5			█	█	█	█	█	█	█	█	█	█	█	█	█	█	█	█
M6				█	█	█	█	█	█	█	█	█	█	█	█	█	█	█
M8					█	█	█	█	█	█	█	█	█	█	█	█	█	█
M10						█	█	█	█	█	█	█	█	█	█	█	█	█
M12							█	█	█	█	█	█	█	█	█	█	█	█
M16								█	█	█	█	█	█	█	█	█	█	█
M20									█	█	█	█	█	█	█	█	█	█

SCREW SIZE NOM.	X	Y	Z
	BODY DRILL SIZE	C'SINK DEPTH (REF)	C'SINK DIA MIN
M3	3.4	1.61	6.72
M4	4.5	2.18	8.96
M5	5.6	2.60	11.20
M6	6.8	3.22	13.44
M8	8.8	4.46	17.92
M10	10.8	5.45	22.40
M12	12.8	6.69	26.88
M16	16.75	7.80	33.60
M20	20.75	8.96	40.32

- Lengths to the left of heavy line (█) threaded to head.
- Lengths to the right of heavy line (█) have standard minimum thread lengths of two times the nominal thread diameter plus 12 mm.

**NOTES & SPECIFICATIONS:**

Material, Class 12.9  
ANSI B18.3.5M  
ASTM F835M

CODING CONTINUED ON FOLLOWING PAGE

A

B

C

D

E

# SOCKET FLATHEAD CAP SCREW CODING

(UNCOATED)  
(F03 SERIES)

GLOBAL STANDARD COMPONENTS



Assembly

07/25/08

B

NAAMS CODE	NOM. SIZE, PITCH AND LENGTH
F030305	M3x0.5x6
F030306	M3x0.5x8
F030307	M3x0.5x10
F030308	M3x0.5x12
F030309	M3x0.5x16
F030310	M3x0.5x20
F030311	M3x0.5x25
F030312	M3x0.5x30
F030406	M4x0.7x8
F030407	M4x0.7x10
F030408	M4x0.7x12
F030409	M4x0.7x16
F030410	M4x0.7x20
F030411	M4x0.7x25
F030412	M4x0.7x30
F030413	M4x0.7x35
F030414	M4x0.7x40
F030506	M5x0.8x8
F030507	M5x0.8x10
F030508	M5x0.8x12
F030509	M5x0.8x16
F030510	M5x0.8x20
F030511	M5x0.8x25
F030512	M5x0.8x30
F030513	M5x0.8x35
F030514	M5x0.8x40
F030515	M5x0.8x45
F030516	M5x0.8x50
F030606	M6x1.0x8
F030607	M6x1.0x10
F030608	M6x1.0x12
F030609	M6x1.0x16
F030610	M6x1.0x20
F030611	M6x1.0x25

NAAMS CODE	NOM. SIZE, PITCH AND LENGTH
F030612	M6x1.0x30
F030613	M6x1.0x35
F030614	M6x1.0x40
F030615	M6x1.0x45
F030616	M6x1.0x50
F030807	M8x1.25x10
F030808	M8x1.25x12
F030809	M8x1.25x16
F030810	M8x1.25x20
F030811	M8x1.25x25
F030812	M8x1.25x30
F030813	M8x1.25x35
F030814	M8x1.25x40
F030815	M8x1.25x45
F030816	M8x1.25x50
F030817	M8x1.25x55
F030818	M8x1.25x60
F030820	M8x1.25x70
F031008	M10x1.5x12
F031009	M10x1.5x16
F031010	M10x1.5x20
F031011	M10x1.5x25
F031012	M10x1.5x30
F031013	M10x1.5x35
F031014	M10x1.5x40
F031015	M10x1.5x45
F031016	M10x1.5x50
F031017	M10x1.5x55
F031018	M10x1.5x60
F031020	M10x1.5x70
F031022	M10x1.5x80
F031023	M10x1.5x90
F031024	M10x1.5x100
F031210	M12x1.75x20

NAAMS CODE	NOM. SIZE, PITCH AND LENGTH
F031211	M12x1.75x25
F031212	M12x1.75x30
F031213	M12x1.75x35
F031214	M12x1.75x40
F031215	M12x1.75x45
F031216	M12x1.75x50
F031217	M12x1.75x55
F031218	M12x1.75x60
F031220	M12x1.75x70
F031222	M12x1.75x80
F031223	M12x1.75x90
F031224	M12x1.75x100
F031612	M16x2.0x30
F031613	M16x2.0x35
F031614	M16x2.0x40
F031615	M16x2.0x45
F031616	M16x2.0x50
F031617	M16x2.0x55
F031618	M16x2.0x60
F031620	M16x2.0x70
F031622	M16x2.0x80
F031623	M16x2.0x90
F031624	M16x2.0x100
F032013	M20x2.5x35
F032014	M20x2.5x40
F032015	M20x2.5x45
F032016	M20x2.5x50
F032017	M20x2.5x55
F032018	M20x2.5x60
F032020	M20x2.5x70
F032022	M20x2.5x80
F032023	M20x2.5x90
F032024	M20x2.5x100

A

# SOCKET FLATHEAD CAP SCREW CODING

(BLUE COATED)  
(F03 SERIES)

GLOBAL STANDARD COMPONENTS

TM **NAAMS**



Assembly

07/25/08

NAAMS CODE	NOM. SIZE, PITCH AND LENGTH
F030305B	M3x0.5x6
F030306B	M3x0.5x8
F030307B	M3x0.5x10
F030308B	M3x0.5x12
F030309B	M3x0.5x16
F030310B	M3x0.5x20
F030311B	M3x0.5x25
F030312B	M3x0.5x30
F030406B	M4x0.7x8
F030407B	M4x0.7x10
F030408B	M4x0.7x12
F030409B	M4x0.7x16
F030410B	M4x0.7x20
F030411B	M4x0.7x25
F030412B	M4x0.7x30
F030413B	M4x0.7x35
F030414B	M4x0.7x40
F030506B	M5x0.8x8
F030507B	M5x0.8x10
F030508B	M5x0.8x12
F030509B	M5x0.8x16
F030510B	M5x0.8x20
F030511B	M5x0.8x25
F030512B	M5x0.8x30
F030513B	M5x0.8x35
F030514B	M5x0.8x40
F030515B	M5x0.8x45
F030516B	M5x0.8x50
F030606B	M6x1.0x8
F030607B	M6x1.0x10
F030608B	M6x1.0x12
F030609B	M6x1.0x16
F030610B	M6x1.0x20
F030611B	M6x1.0x25

NAAMS CODE	NOM. SIZE, PITCH AND LENGTH
F030612B	M6x1.0x30
F030613B	M6x1.0x35
F030614B	M6x1.0x40
F030615B	M6x1.0x45
F030616B	M6x1.0x50
F030807B	M8x1.25x10
F030808B	M8x1.25x12
F030809B	M8x1.25x16
F030810B	M8x1.25x20
F030811B	M8x1.25x25
F030812B	M8x1.25x30
F030813B	M8x1.25x35
F030814B	M8x1.25x40
F030815B	M8x1.25x45
F030816B	M8x1.25x50
F030817B	M8x1.25x55
F030818B	M8x1.25x60
F030820B	M8x1.25x70
F031008B	M10x1.5x12
F031009B	M10x1.5x16
F031010B	M10x1.5x20
F031011B	M10x1.5x25
F031012B	M10x1.5x30
F031013B	M10x1.5x35
F031014B	M10x1.5x40
F031015B	M10x1.5x45
F031016B	M10x1.5x50
F031017B	M10x1.5x55
F031018B	M10x1.5x60
F031020B	M10x1.5x70
F031022B	M10x1.5x80
F031023B	M10x1.5x90
F031024B	M10x1.5x100
F031210B	M12x1.75x20

NAAMS CODE	NOM. SIZE, PITCH AND LENGTH
F031211B	M12x1.75x25
F031212B	M12x1.75x30
F031213B	M12x1.75x35
F031214B	M12x1.75x40
F031215B	M12x1.75x45
F031216B	M12x1.75x50
F031217B	M12x1.75x55
F031218B	M12x1.75x60
F031220B	M12x1.75x70
F031222B	M12x1.75x80
F031223B	M12x1.75x90
F031224B	M12x1.75x100
F031612B	M16x2.0x30
F031613B	M16x2.0x35
F031614B	M16x2.0x40
F031615B	M16x2.0x45
F031616B	M16x2.0x50
F031617B	M16x2.0x55
F031618B	M16x2.0x60
F031620B	M16x2.0x70
F031622B	M16x2.0x80
F031623B	M16x2.0x90
F031624B	M16x2.0x100
F032013B	M20x2.5x35
F032014B	M20x2.5x40
F032015B	M20x2.5x45
F032016B	M20x2.5x50
F032017B	M20x2.5x55
F032018B	M20x2.5x60
F032020B	M20x2.5x70
F032022B	M20x2.5x80
F032023B	M20x2.5x90
F032024B	M20x2.5x100

A



# SOCKET HEAD SHOULDER SCREW

(F04 SERIES)

GLOBAL STANDARD COMPONENTS

TM **NAAMS**



Assembly

07/25/08

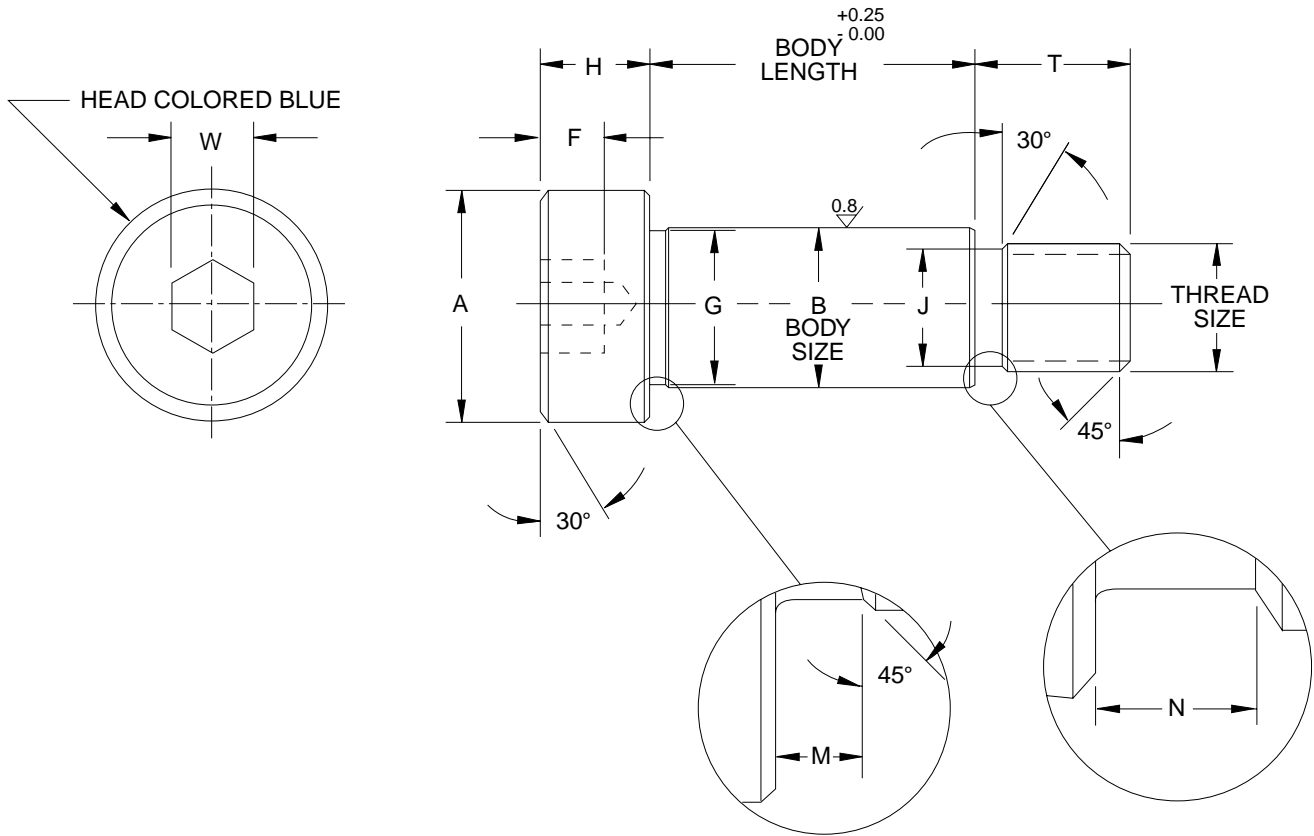

		STOCK SIZES													
NOM.	BODY SIZE	BODY LENGTHS													
		10	12	16	20	25	30	40	50	60	70	80	90	100	120
6		✓	✓	✓	✓	✓	✓	✓	✓						
8			✓	✓	✓	✓	✓	✓	✓	✓					
10				✓	✓	✓	✓	✓	✓	✓	✓				
12					✓	✓	✓	✓	✓	✓	✓	✓			
16						✓	✓	✓	✓	✓	✓	✓	✓		
20							✓	✓	✓	✓	✓	✓	✓	✓	
24								✓	✓	✓	✓	✓	✓	✓	✓

**NOTES & SPECIFICATIONS:**

Material, heat treated alloy steel. Ultimate min. tensile 1100MPa, single shear strength 660MPa.  
ANSI B18.3.3M

CODING ON FOLLOWING PAGE

C

A

B

D

# SOCKET HEAD SHOULDER SCREW CODING

(UNCOATED)  
(F04 SERIES)

GLOBAL STANDARD COMPONENTS

TM **NAAMS**



Assembly

07/25/08

**B**

BODY SIZE	NOM. THREAD SIZE	PITCH	A MAX	F MIN	B <sub>h8</sub>		G MIN	H MAX
					MAX	MIN		
6	M5	0.8	10.00	2.4	6.0	5.982	5.42	4.50
8	M6	1.0	13.00	3.3	8.0	7.978	7.42	5.50
10	M8	1.25	16.00	4.2	10.0	9.978	9.42	7.00
12	M10	1.5	18.00	4.9	12.0	11.973	11.42	8.00
16	M12	1.75	24.00	6.6	16.0	15.973	15.42	10.00
20	M16	2.0	30.00	8.8	20.0	19.967	19.42	14.00
24	M20	2.5	36.00	10.0	24.0	23.967	23.42	16.00

BODY SIZE	J	M	N	T	W	RECOMMENDED SEATING TORQUE Nm	TAP DRILL SIZE
	MIN	MAX	MAX	MAX	NOM.		
6	3.68	2.5	2.40	9.75	3	7	4.2
8	4.40	2.5	2.60	11.25	4	12	5.0
10	6.03	2.5	2.80	13.25	5	29	6.75
12	7.69	2.5	3.00	16.40	6	57	8.5
16	9.35	2.5	4.00	18.40	8	100	10.25
20	12.96	2.5	4.80	22.40	10	240	14
24	16.30	3.0	5.60	27.40	12	470	17.5

NAAMS CODE	BODY SIZE x BODY LENGTH	NAAMS CODE	BODY SIZE x BODY LENGTH	NAAMS CODE	BODY SIZE x BODY LENGTH	NAAMS CODE	BODY SIZE x BODY LENGTH
F040607	6 x 10	F040820	8 x 70	F041216	12 x 50	F042014	20 x 40
F040608	6 x 12	F041009	10 x 16	F041218	12 x 60	F042016	20 x 50
F040609	6 x 16	F041010	10 x 20	F041220	12 x 70	F042018	20 x 60
F040610	6 x 20	F041011	10 x 25	F041222	12 x 80	F042020	20 x 70
F040611	6 x 25	F041012	10 x 30	F041223	12 x 90	F042022	20 x 80
F040612	6 x 30	F041014	10 x 40	F041224	12 x 100	F042023	20 x 90
F040614	6 x 40	F041016	10 x 50	F041612	16 x 30	F042024	20 x 100
F040616	6 x 50	F041018	10 x 60	F041614	16 x 40	F042026	20 x 120
F040808	8 x 12	F041020	10 x 70	F041616	16 x 50	F042416	24 x 50
F040809	8 x 16	F041022	10 x 80	F041618	16 x 60	F042418	24 x 60
F040810	8 x 20	F041209	12 x 16	F041620	16 x 70	F042420	24 x 70
F040811	8 x 25	F041210	12 x 20	F041622	16 x 80	F042422	24 x 80
F040812	8 x 30	F041211	12 x 25	F041623	16 x 90	F042423	24 x 90
F040814	8 x 40	F041212	12 x 30	F041624	16 x 100	F042424	24 x 100
F040816	8 x 50	F041214	12 x 40	F041626	16 x 120	F042426	24 x 120

**A**

# SOCKET HEAD SHOULDER SCREW CODING

(BLUE COATED)  
(F04 SERIES)

GLOBAL STANDARD COMPONENTS



Assembly

07/25/08

BODY SIZE	NOM. THREAD SIZE	PITCH	A MAX	F MIN	B <sub>h8</sub>		G MIN	H MAX
					MAX	MIN		
6	M5	0.8	10.00	2.4	6.0	5.982	5.42	4.50
8	M6	1.0	13.00	3.3	8.0	7.978	7.42	5.50
10	M8	1.25	16.00	4.2	10.0	9.978	9.42	7.00
12	M10	1.5	18.00	4.9	12.0	11.973	11.42	8.00
16	M12	1.75	24.00	6.6	16.0	15.973	15.42	10.00
20	M16	2.0	30.00	8.8	20.0	19.967	19.42	14.00
24	M20	2.5	36.00	10.0	24.0	23.967	23.42	16.00

BODY SIZE	J	M	N	T	W	RECOMMENDED SEATING TORQUE Nm	TAP DRILL SIZE
	MIN	MAX	MAX	MAX	NOM.		
6	3.68	2.5	2.40	9.75	3	7	4.2
8	4.40	2.5	2.60	11.25	4	12	5.0
10	6.03	2.5	2.80	13.25	5	29	6.75
12	7.69	2.5	3.00	16.40	6	57	8.5
16	9.35	2.5	4.00	18.40	8	100	10.25
20	12.96	2.5	4.80	22.40	10	240	14
24	16.30	3.0	5.60	27.40	12	470	17.5

NAAMS CODE	BODY SIZE x BODY LENGTH	NAAMS CODE	BODY SIZE x BODY LENGTH	NAAMS CODE	BODY SIZE x BODY LENGTH	NAAMS CODE	BODY SIZE x BODY LENGTH
F040607B	6 x 10	F040820B	8 x 70	F041216B	12 x 50	F042014B	20 x 40
F040608B	6 x 12	F041009B	10 x 16	F041218B	12 x 60	F042016B	20 x 50
F040609B	6 x 16	F041010B	10 x 20	F041220B	12 x 70	F042018B	20 x 60
F040610B	6 x 20	F041011B	10 x 25	F041222B	12 x 80	F042020B	20 x 70
F040611B	6 x 25	F041012B	10 x 30	F041223B	12 x 90	F042022B	20 x 80
F040612B	6 x 30	F041014B	10 x 40	F041224B	12 x 100	F042023B	20 x 90
F040614B	6 x 40	F041016B	10 x 50	F041612B	16 x 30	F042024B	20 x 100
F040616B	6 x 50	F041018B	10 x 60	F041614B	16 x 40	F042026B	20 x 120
F040808B	8 x 12	F041020B	10 x 70	F041616B	16 x 50	F042416B	24 x 50
F040809B	8 x 16	F041022B	10 x 80	F041618B	16 x 60	F042418B	24 x 60
F040810B	8 x 20	F041209B	12 x 16	F041620B	16 x 70	F042420B	24 x 70
F040811B	8 x 25	F041210B	12 x 20	F041622B	16 x 80	F042422B	24 x 80
F040812B	8 x 30	F041211B	12 x 25	F041623B	16 x 90	F042423B	24 x 90
F040814B	8 x 40	F041212B	12 x 30	F041624B	16 x 100	F042424B	24 x 100
F040816B	8 x 50	F041214B	12 x 40	F041626B	16 x 120	F042426B	24 x 120

A

# HEX HEAD SCREW

(F05 SERIES)

A

**(CLASS 10.9)**

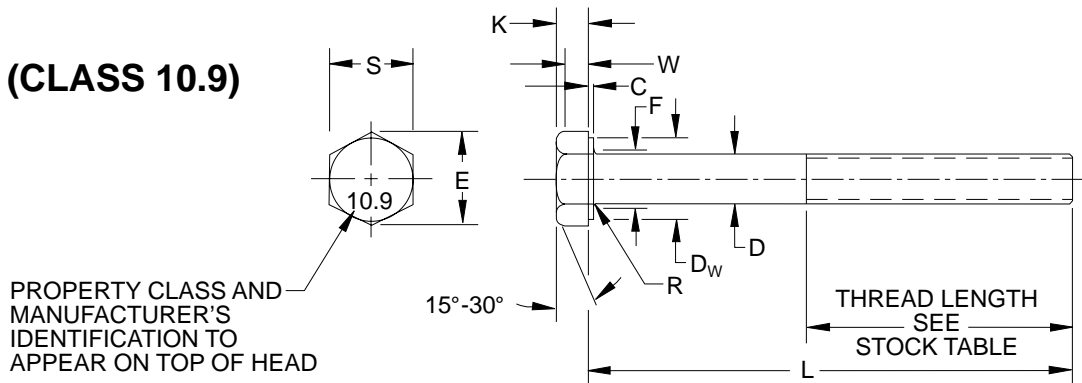

NOMINAL SCREW DIA. & THREAD PITCH	D BODY DIAMETER		S WIDTH ACROSS FLATS		E WIDTH ACROSS CORNERS		K HEAD HEIGHT		W WRENCHING HEIGHT	F FILLET TRANS-DIA.	R RADIUS OF FILLET	C WASHER FACE THICKNESS		D <sub>w</sub> WASH FACE DIA.
	MAX	MIN	MAX	MIN	MAX	MIN	MAX	MIN	MIN	MAX	MIN	MAX	MIN	MIN
M12x1.75	12.00	11.73	18.00	17.73	20.78	20.03	7.76	7.24	5.2	13.7	0.6	0.6	0.3	16.6
M14x2	14.00	13.73	21.00	20.67	24.25	23.35	9.09	8.51	6.2	15.7	0.6	0.6	0.3	19.6
M16x2	16.00	15.73	24.00	23.67	27.71	26.75	10.32	9.68	7.0	17.7	0.6	0.8	0.4	22.5
M20x2.5	20.00	19.67	30.00	29.16	34.64	32.95	12.88	12.12	8.8	22.4	0.8	0.8	0.4	27.7
M24x3	24.00	23.67	36.00	35.00	41.57	39.55	15.44	14.56	10.5	26.4	0.8	0.8	0.4	33.2
M30x3.5	30.00	29.67	46.00	45.00	53.12	50.85	19.48	17.92	13.1	33.4	1.0	0.8	0.4	42.7
M36x4	36.00	35.61	55.00	53.80	63.51	60.79	23.38	21.62	15.8	39.4	1.0	0.8	0.4	51.1

THREAD SIZE NOM	STOCK SIZES (L)																																					
	20	25	30	35	40	45	50	55	60	65	70	75	80	90	100	110	120	130	140	150	160	170	180	190	200	210	220	240	260	280	300	320	330	340				
M12																																						
M14																																						
M16																																						
M20																																						
M24																																						
M30																																						
M36																																						

- Lengths to the left of heavy line (█) threaded to head.
- Lengths to the right of heavy line (█) have standard minimum thread lengths of two times the nominal thread diameter plus 12 mm.

**NOTES & SPECIFICATIONS:**

ANSI B18.2.3.1M  
 ASTM F568M  
 CLASS 10.9

CODING ON FOLLOWING PAGE  
 FOR SCREWS SMALLER THAN M12, SEE PAGES F-11.5 AND F-11.6

D  
 B  
 C

# HEX HEAD SCREW CODING

(UNCOATED)  
(F05 SERIES)

**A**

## (CLASS 10.9)

NAAMS CODE	NOM. SIZE, PITCH AND LENGTH
F051210	M12-1.75 x 20
F051211	M12-1.75 x 25
F051212	M12-1.75 x 30
F051213	M12-1.75 x 35
F051214	M12-1.75 x 40
F051215	M12-1.75 x 45
F051216	M12-1.75 x 50
F051217	M12-1.75 x 55
F051218	M12-1.75 x 60
F051219	M12-1.75 x 65
F051220	M12-1.75 x 70
F051221	M12-1.75 x 75
F051222	M12-1.75 x 80
F051223	M12-1.75 x 90
F051224	M12-1.75 x 100
F051225	M12-1.75 x 110
F051226	M12-1.75 x 120
F051411	M14-2.0 x 25
F051412	M14-2.0 x 30
F051413	M14-2.0 x 35
F051414	M14-2.0 x 40
F051415	M14-2.0 x 45
F051416	M14-2.0 x 50
F051417	M14-2.0 x 55
F051418	M14-2.0 x 60
F051420	M14-2.0 x 70
F051422	M14-2.0 x 80
F051423	M14-2.0 x 90
F051424	M14-2.0 x 100
F051425	M14-2.0 x 110
F051613	M16-2.0 x 35
F051614	M16-2.0 x 40
F051615	M16-2.0 x 45
F051616	M16-2.0 x 50
F051617	M16-2.0 x 55
F051618	M16-2.0 x 60
F051620	M16-2.0 x 70
F051621	M16-2.0 x 75
F051622	M16-2.0 x 80
F051623	M16-2.0 x 90
F051624	M16-2.0 x 100

NAAMS CODE	NOM. SIZE, PITCH AND LENGTH
F051625	M16-2.0 x 110
F051626	M16-2.0 x 120
F052014	M20-2.5 x 40
F052015	M20-2.5 x 45
F052016	M20-2.5 x 50
F052018	M20-2.5 x 60
F052020	M20-2.5 x 70
F052022	M20-2.5 x 80
F052023	M20-2.5 x 90
F052024	M20-2.5 x 100
F052025	M20-2.5 x 110
F052026	M20-2.5x 120
F052027	M20-2.5 x 130
F052028	M20-2.5 x 140
F052029	M20-2.5 x 150
F052030	M20-2.5 x 160
F052031	M20-2.5 x 170
F052032	M20-2.5 x 180
F052033	M20-2.5 x 190
F052034	M20-2.5 x 200
F052036	M20-2.5 x 220
F052037	M20-2.5x 240
F052038	M20-2.5 x 260
F052039	M20-2.5 x 280
F052040	M20-2.5 x 300
F052043	M20-2.5x 340
F052416	M24-3.0 x 50
F052418	M24-3.0 x 60
F052420	M24-3.0 x 70
F052422	M24-3.0 x 80
F052424	M24-3.0 x 100
F052425	M24-3.0 x 110
F052426	M24-3.0x 120
F052427	M24-3.0 x 130
F052428	M24-3.0 x 140
F052429	M24-3.0x 150
F052430	M24-3.0 x 160
F052431	M24-3.0 x 170
F052432	M24-3.0 x 180
F052433	M24-3.0 x 190
F052434	M24-3.0 x 200

NAAMS CODE	NOM. SIZE, PITCH AND LENGTH
F052436	M24-3.0 x 220
F052437	M24-3.0 x 240
F052438	M24-3.0 x 260
F052439	M24-3.0 x 280
F052440	M24-3.0 x 300
F052442	M24-2.0 x 330
F052443	M24-3.0 x 340
F053018	M30-3.5 x 60
F053019	M30-3.5 x 65
F053020	M30-3.5 x 70
F053022	M30-3.5 x 80
F053023	M30-3.5 x 90
F053024	M30-3.5 x 100
F053025	M30-3.5 x 110
F053026	M30-3.5x 120
F053027	M30-3.5 x 130
F053028	M30-3.5x 140
F053029	M30-3.5x 150
F053030	M30-3.5 x 160
F053031	M30-3.5 x 170
F053032	M30-3.5 x 180
F053033	M30-3.5 x 190
F053034	M30-3.5 x 200
F053035	M30-3.5 x 210
F053036	M30-3.5 x 220
F053037	M30-3.5 x 240
F053038	M30-3.5 x 260
F053040	M30-3.5 x 300
F053041	M30-3.5 x 320
F053622	M36-4.0 x 80
F053623	M36-4.0 x 90
F053624	M36-4.0 x 100
F053626	M36-4.0 x 120
F053627	M36-4.0 x 130
F053628	M36-4.0 x 140
F053629	M36-4.0 x 150
F053630	M36-4.0 x 160
F053631	M36-4.0 x 170
F053634	M36-4.0 x 200

**C**  
**B**

FOR SCREWS SMALLER THAN M12, SEE PAGES F-11.5 AND F-11.6

# HEX HEAD SCREW CODING

(BLUE COATED)  
(F05 SERIES)

GLOBAL STANDARD COMPONENTS



Assembly

03/31/10

## (CLASS 10.9)

NAAMS CODE	NOM. SIZE, PITCH AND LENGTH
F051210B	M12-1.75 x 20
F051211B	M12-1.75 x 25
F051212B	M12-1.75 x 30
F051213B	M12-1.75 x 35
F051214B	M12-1.75 x 40
F051215B	M12-1.75 x 45
F051216B	M12-1.75 x 50
F051217B	M12-1.75 x 55
F051218B	M12-1.75 x 60
F051219B	M12-1.75 x 65
F051220B	M12-1.75 x 70
F051221B	M12-1.75 x 75
F051222B	M12-1.75 x 80
F051223B	M12-1.75 x 90
F051224B	M12-1.75 x 100
F051225B	M12-1.75 x 110
F051226B	M12-1.75 x 120
F051411B	M14-2.0 x 25
F051412B	M14-2.0 x 30
F051413B	M14-2.0 x 35
F051414B	M14-2.0 x 40
F051415B	M14-2.0 x 45
F051416B	M14-2.0 x 50
F051417B	M14-2.0 x 55
F051418B	M14-2.0 x 60
F051420B	M14-2.0 x 70
F051422B	M14-2.0 x 80
F051423B	M14-2.0 x 90
F051424B	M14-2.0 x 100
F051425B	M14-2.0 x 110
F051613B	M16-2.0 x 35
F051614B	M16-2.0 x 40
F051615B	M16-2.0 x 45
F051616B	M16-2.0 x 50
F051617B	M16-2.0 x 55
F051618B	M16-2.0 x 60
F051620B	M16-2.0 x 70
F051621B	M16-2.0 x 75
F051622B	M16-2.0 x 80
F051623B	M16-2.0 x 90
F051624B	M16-2.0 x 100

NAAMS CODE	NOM. SIZE, PITCH AND LENGTH
F051625B	M16-2.0 x 110
F051626B	M16-2.0 x 120
F052014B	M20-2.5 x 40
F052015B	M20-2.5 x 45
F052016B	M20-2.5 x 50
F052018B	M20-2.5 x 60
F052020B	M20-2.5 x 70
F052022B	M20-2.5 x 80
F052023B	M20-2.5 x 90
F052024B	M20-2.5 x 100
F052025B	M20-2.5 x 110
F052026B	M20-2.5x 120
F052027B	M20-2.5 x 130
F052028B	M20-2.5 x 140
F052029B	M20-2.5 x 150
F052030B	M20-2.5 x 160
F052031B	M20-2.5 x 170
F052032B	M20-2.5 x 180
F052033B	M20-2.5 x 190
F052034B	M20-2.5 x 200
F052036B	M20-2.5 x 220
F052037B	M20-2.5x 240
F052038B	M20-2.5 x 260
F052039B	M20-2.5 x 280
F052040B	M20-2.5 x 300
F052043B	M20-2.5x 340
F052416B	M24-3.0 x 50
F052418B	M24-3.0 x 60
F052420B	M24-3.0 x 70
F052422B	M24-3.0 x 80
F052424B	M24-3.0 x 100
F052425B	M24-3.0 x 110
F052426B	M24-3.0x 120
F052427B	M24-3.0 x 130
F052428B	M24-3.0 x 140
F052429B	M24-3.0x 150
F052430B	M24-3.0 x 160
F052431B	M24-3.0 x 170
F052432B	M24-3.0 x 180
F052433B	M24-3.0 x 190
F052434B	M24-3.0 x 200

NAAMS CODE	NOM. SIZE, PITCH AND LENGTH
F052436B	M24-3.0 x 220
F052437B	M24-3.0 x 240
F052438B	M24-3.0 x 260
F052439B	M24-3.0 x 280
F052440B	M24-3.0 x 300
F052442B	M24-2.0 x 330
F052443B	M24-3.0 x 340
F053018B	M30-3.5 x 60
F053019B	M30-3.5 x 65
F053020B	M30-3.5 x 70
F053022B	M30-3.5 x 80
F053023B	M30-3.5 x 90
F053024B	M30-3.5 x 100
F053025B	M30-3.5 x 110
F053026B	M30-3.5x 120
F053027B	M30-3.5 x 130
F053028B	M30-3.5x 140
F053029B	M30-3.5x 150
F053030B	M30-3.5 x 160
F053031B	M30-3.5 x 170
F053032B	M30-3.5 x 180
F053033B	M30-3.5 x 190
F053034B	M30-3.5 x 200
F053035B	M30-3.5 x 210
F053036B	M30-3.5 x 220
F053037B	M30-3.5 x 240
F053038B	M30-3.5 x 260
F053040B	M30-3.5 x 300
F053041B	M30-3.5 x 320
F053622B	M36-4.0 x 80
F053623B	M36-4.0 x 90
F053624B	M36-4.0 x 100
F053626B	M36-4.0 x 120
F053627B	M36-4.0 x 130
F053628B	M36-4.0 x 140
F053629B	M36-4.0 x 150
F053630B	M36-4.0 x 160
F053631B	M36-4.0 x 170
F053634B	M36-4.0 x 200

FOR SCREWS SMALLER THAN M12, SEE PAGES F-11.5 AND F-11.6

A



# HEX HEAD SCREW CODING

(UNCOATED)  
(F05 SERIES)

## (CLASS 10.9)

NAAMS CODE	NOM. SIZE, PITCH AND LENGTH	NAAMS CODE	NOM. SIZE, PITCH AND LENGTH	NAAMS CODE	NOM. SIZE, PITCH AND LENGTH
F050510	M5-0.8 x 6	F050810	M8-1.25 x 10	F051010	M10-1.5 x 10
F050511	M5-0.8 x 8	F050811	M8-1.25 x 12	F051011	M10-1.5 x 12
F050512	M5-0.8 x 10	F050812	M8-1.25 x 16	F051012	M10-1.5 x 16
F050513	M5-0.8 x 12	F050813	M8-1.25 x 20	F051013	M10-1.5 x 20
F050514	M5-0.8 x 16	F050814	M8-1.25 x 25	F051014	M10-1.5 x 25
F050515	M5-0.8 x 20	F050815	M8-1.25 x 30	F051015	M10-1.5 x 30
F050516	M5-0.8 x 25	F050816	M8-1.25 x 35	F051016	M10-1.5 x 35
F050517	M5-0.8 x 30	F050817	M8-1.25 x 40	F051017	M10-1.5 x 40
F050518	M5-0.8 x 35	F050818	M8-1.25 x 45	F051018	M10-1.5 x 45
F050519	M5-0.8 x 40	F050819	M8-1.25 x 50	F051019	M10-1.5 x 50
F050520	M5-0.8 x 45	F050820	M8-1.25 x 55	F051020	M10-1.5 x 55
F050521	M5-0.8 x 50	F050821	M8-1.25 x 60	F051021	M10-1.5 x 60
F050522	M5-0.8 x 55	F050822	M8-1.25 x 65	F051022	M10-1.5 x 65
F050523	M5-0.8 x 60	F050823	M8-1.25 x 70	F051023	M10-1.5 x 70
F050524	M5-0.8 x 65	F050824	M8-1.25 x 75	F051024	M10-1.5 x 75
F050525	M5-0.8 x 70	F050825	M8-1.25 x 80	F051025	M10-1.5 x 80
F050610	M6-1.0 x 8	F050826	M8-1.25 x 90	F051026	M10-1.5 x 90
F050611	M6-1.0 x 10	F050827	M8-1.25 x 100	F051027	M10-1.5 x 100
F050612	M6-1.0 x 12	F050828	M8-1.25 x 110	F051028	M10-1.5 x 110
F050613	M6-1.0 x 16	F050829	M8-1.25 x 120	F051029	M10-1.5 x 120
F050614	M6-1.0 x 20	F050830	M8-1.25 x 130	F051030	M10-1.5 x 130
F050615	M6-1.0 x 25	F050831	M8-1.25 x 140	F051031	M10-1.5 x 140
F050616	M6-1.0 x 30	F050832	M8-1.25 x 150	F051032	M10-1.5 x 150
F050617	M6-1.0 x 35	F050833	M8-1.25 x 160	F051033	M10-1.5 x 160
F050618	M6-1.0 x 40	F050834	M8-1.25 x 170	F051034	M10-1.5 x 170
F050619	M6-1.0 x 45	F050835	M8-1.25 x 180	F051035	M10-1.5 x 180
F050620	M6-1.0 x 50	F050836	M8-1.25 x 190	F051036	M10-1.5 x 190
F050621	M6-1.0 x 55	F050837	M8-1.25 x 200	F051037	M10-1.5 x 200
F050622	M6-1.0 x 60				
F050623	M6-1.0 x 65				
F050624	M6-1.0 x 70				
F050625	M6-1.0 x 75				
F050626	M6-1.0 x 80				
F050627	M6-1.0 x 90				
F050628	M6-1.0 x 100				
F050629	M6-1.0 x 110				
F050630	M6-1.0 x 120				

FOR SCREWS LARGER THAN M10, SEE PAGES F-11.2 THRU F-11.4



# HEX HEAD SCREW

(F06 SERIES)

GLOBAL STANDARD COMPONENTS

# NAAMS



Assembly

07/25/08

**(CLASS 12.9)**

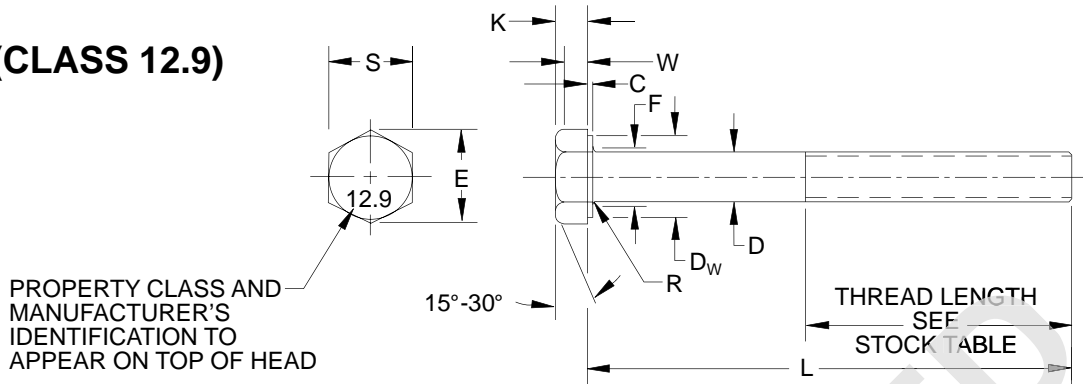

PROPERTY CLASS AND  
MANUFACTURER'S  
IDENTIFICATION TO  
APPEAR ON TOP OF HEAD

NOMINAL SCREW DIA. & THREAD PITCH	D BODY DIAMETER		S WIDTH ACROSS FLATS		E WIDTH ACROSS CORNERS		K HEAD HEIGHT		W	F	R	C WASHER FACE THICKNESS		D <sub>w</sub>
	MAX	MIN	MAX	MIN	MAX	MIN	MAX	MIN	WREN- CHING HEIGHT	FILET TRANS- TION DIA.	RADIUS OF FILET	MAX	MIN	MIN
M6x1	6.00	5.82	10.00	9.78	11.55	11.05	4.15	3.85	2.8	6.8	0.3	0.5	0.2	8.9
M8x1.25	8.00	7.78	13.00	12.73	15.01	14.38	5.50	5.10	3.7	9.2	0.4	0.6	0.3	11.6
M10x1.5	10.00	9.78	16.00	15.73	18.48	17.77	6.63	6.17	4.5	11.2	0.4	0.6	0.3	14.6
M12x1.75	12.00	11.73	18.00	17.73	20.78	20.03	7.76	7.24	5.2	13.7	0.6	0.6	0.3	16.6
M14x2	14.00	13.73	21.00	20.67	24.25	23.35	9.09	8.51	6.2	15.7	0.6	0.6	0.3	19.6
M16x2	16.00	15.73	24.00	23.67	27.71	26.75	10.32	9.68	7.0	17.7	0.6	0.8	0.4	22.5
M20x2.5	20.00	19.67	30.00	29.16	34.64	32.95	12.88	12.12	8.8	22.4	0.8	0.8	0.4	27.7
M24x3	24.00	23.67	36.00	35.00	41.57	39.55	15.44	14.56	10.5	26.4	0.8	0.8	0.4	33.2
M30x3.5	30.00	29.67	46.00	45.00	53.12	50.85	19.48	17.92	13.1	33.4	1.0	0.8	0.4	42.7
M36x4	36.00	35.61	55.00	53.80	63.51	60.79	23.38	21.62	15.8	39.4	1.0	0.8	0.4	51.1

CONTINUED ON FOLLOWING PAGE

# HEX HEAD SCREW

(F06 SERIES CONTINUED)

GLOBAL STANDARD COMPONENTS



Assembly

07/25/08

(CLASS 12.9 CONTINUED)

THREAD SIZE NOM	STOCK SIZES																											
	10	12	16	20	25	30	35	40	45	50	55	60	65	70	75	80	85	90	100	110	120	130	140	150	160	180	200	
M6	■	■	■	■	■	■	■	■	■	■	■	■	■	■	■	■	■	■	■	■	■	■	■	■	■	■	■	■
M8		■	■	■	■	■	■	■	■	■	■	■	■	■	■	■	■	■	■	■	■	■	■	■	■	■	■	■
M10				■	■	■	■	■	■	■	■	■	■	■	■	■	■	■	■	■	■	■	■	■	■	■	■	■

THREAD SIZE NOM	STOCK SIZES																																					
	20	25	30	35	40	45	50	55	60	65	70	75	80	90	100	110	120	130	140	150	160	170	180	190	200	210	220	240	260	280	300	320	330	340				
M12	■	■	■	■	■	■	■	■	■	■	■	■	■	■	■	■	■	■	■	■	■	■	■	■	■	■	■	■	■	■	■	■	■	■	■			
M14		■	■	■	■	■	■	■	■	■	■	■	■	■	■	■	■	■	■	■	■	■	■	■	■	■	■	■	■	■	■	■	■	■	■	■		
M16			■	■	■	■	■	■	■	■	■	■	■	■	■	■	■	■	■	■	■	■	■	■	■	■	■	■	■	■	■	■	■	■	■	■		
M20				■	■	■	■	■	■	■	■	■	■	■	■	■	■	■	■	■	■	■	■	■	■	■	■	■	■	■	■	■	■	■	■	■	■	
M24					■	■	■	■	■	■	■	■	■	■	■	■	■	■	■	■	■	■	■	■	■	■	■	■	■	■	■	■	■	■	■	■	■	
M30						■	■	■	■	■	■	■	■	■	■	■	■	■	■	■	■	■	■	■	■	■	■	■	■	■	■	■	■	■	■	■	■	
M36							■	■	■	■	■	■	■	■	■	■	■	■	■	■	■	■	■	■	■	■	■	■	■	■	■	■	■	■	■	■	■	■

- Lengths to the left of heavy line (■) threaded to head.
- Lengths to the right of heavy line (■) have standard minimum thread lengths of two times the nominal thread diameter plus 12 mm.

**NOTES & SPECIFICATIONS:**

ANSI B18.2.3.1M  
 ASTM F568M  
 CLASS 12.9  
 Screw to be colored blue.

CODING ON FOLLOWING PAGE

F

A

D

# HEX HEAD SCREW CODING

(F06 SERIES)

GLOBAL STANDARD COMPONENTS



Assembly

07/25/08

## (CLASS 12.9)

NAAMS CODE	NOM. SIZE, PITCH AND LENGTH
F060610	M6-1 x 10
F060611	M6-1 x 12
F060612	M6-1 x 16
F060613	M6-1 x 20
F060614	M6-1 x 25
F060615	M6-1 x 30
F060616	M6-1 x 35
F060617	M6-1 x 40
F060618	M6-1 x 45
F060619	M6-1 x 50
F060620	M6-1 x 55
F060621	M6-1 x 60
F060622	M6-1 x 65
F060623	M6-1 x 70
F060624	M6-1 x 75
F060625	M6-1 x 80
F060810	M8-1.25 x 12
F060811	M8-1.25 x 16
F060812	M8-1.25 x 20
F060813	M8-1.25 x 25
F060814	M8-1.25 x 30
F060815	M8-1.25 x 35
F060816	M8-1.25 x 40
F060817	M8-1.25 x 45
F060818	M8-1.25 x 50
F060819	M8-1.25 x 55
F060820	M8-1.25 x 60
F060821	M8-1.25 x 65
F060822	M8-1.25 x 70
F060823	M8-1.25 x 75
F060824	M8-1.25 x 80

NAAMS CODE	NOM. SIZE, PITCH AND LENGTH
F061010	M10-1.5 x 20
F061011	M10-1.5 x 25
F061012	M10-1.5 x 30
F061013	M10-1.5 x 35
F061014	M10-1.5 x 40
F061015	M10-1.5 x 45
F061016	M10-1.5 x 50
F061017	M10-1.5 x 55
F061018	M10-1.5 x 60
F061019	M10-1.5 x 65
F061020	M10-1.5 x 70
F061021	M10-1.5 x 75
F061022	M10-1.5 x 80
F061023	M10-1.5 x 85
F061024	M10-1.5 x 90
F061025	M10-1.5 x 100
F061026	M10-1.5 x 110
F061027	M10-1.5 x 120
F061028	M10-1.5 x 130
F061029	M10-1.5 x 140
F061030	M10-1.5 x 150
F061031	M10-1.5 x 160
F061032	M10-1.5 x 180
F061033	M10-1.5 x 200

B

CONTINUED ON FOLLOWING PAGE

# HEX HEAD SCREW CODING

(F06 SERIES CONTINUED)

GLOBAL STANDARD COMPONENTS



Assembly

07/25/08

## (CLASS 12.9 CONTINUED)

NAAMS CODE	NOM. SIZE, PITCH AND LENGTH
F061210	M12-1.75 x 20
F061211	M12-1.75 x 25
F061212	M12-1.75 x 30
F061213	M12-1.75 x 35
F061214	M12-1.75 x 40
F061215	M12-1.75 x 45
F061216	M12-1.75 x 50
F061217	M12-1.75 x 55
F061218	M12-1.75 x 60
F061219	M12-1.75 x 65
F061220	M12-1.75 x 70
F061221	M12-1.75 x 75
F061222	M12-1.75 x 80
F061223	M12-1.75 x 90
F061224	M12-1.75 x 100
F061225	M12-1.75 x 110
F061226	M12-1.75 x 120
F061411	M14-2.0 x 25
F061412	M14-2.0 x 30
F061413	M14-2.0 x 35
F061414	M14-2.0 x 40
F061415	M14-2.0 x 45
F061416	M14-2.0 x 50
F061417	M14-2.0 x 55
F061418	M14-2.0 x 60
F061420	M14-2.0 x 70
F061422	M14-2.0 x 80
F061423	M14-2.0 x 90
F061424	M14-2.0 x 100
F061425	M14-2.0 x 110
F061613	M16-2.0 x 35
F061614	M16-2.0 x 40
F061615	M16-2.0 x 45
F061616	M16-2.0 x 50
F061617	M16-2.0 x 55
F061618	M16-2.0 x 60
F061620	M16-2.0 x 70
F061621	M16-2.0 x 75
F061622	M16-2.0 x 80
F061623	M16-2.0 x 90
F061624	M16-2.0 x 100

NAAMS CODE	NOM. SIZE, PITCH AND LENGTH
F061625	M16-2.0 x 110
F061626	M16-2.0 x 120
F062014	M20-2.5 x 40
F062015	M20-2.5 x 45
F062016	M20-2.5 x 50
F062018	M20-2.5 x 60
F062020	M20-2.5 x 70
F062022	M20-2.5 x 80
F062023	M20-2.5 x 90
F062024	M20-2.5 x 100
F062025	M20-2.5 x 110
F062026	M20-2.5 x 120
F062027	M20-2.5 x 130
F062028	M20-2.5 x 140
F062029	M20-2.5 x 150
F062030	M20-2.5 x 160
F062031	M20-2.5 x 170
F062032	M20-2.5 x 180
F062033	M20-2.5 x 190
F062034	M20-2.5 x 200
F062036	M20-2.5 x 220
F062037	M20-2.5 x 240
F062038	M20-2.5 x 260
F062039	M20-2.5 x 280
F062040	M20-2.5 x 300
F062043	M20-2.5 x 340
F062416	M24-3.0 x 50
F062418	M24-3.0 x 60
F062420	M24-3.0 x 70
F062422	M24-3.0 x 80
F062424	M24-3.0 x 100
F062425	M24-3.0 x 110
F062426	M24-3.0 x 120
F062427	M24-3.0 x 130
F062428	M24-3.0 x 140
F062429	M24-3.0 x 150
F062430	M24-3.0 x 160
F062431	M24-3.0 x 170
F062432	M24-3.0 x 180
F062433	M24-3.0 x 190
F062434	M24-3.0 x 200

NAAMS CODE	NOM. SIZE, PITCH AND LENGTH
F062436	M24-3.0 x 220
F062437	M24-3.0 x 240
F062438	M24-3.0 x 260
F062439	M24-3.0 x 280
F062440	M24-3.0 x 300
F062442	M24-2.0 x 330
F062443	M24-3.0 x 340
F063018	M30-3.5 x 60
F063019	M30-3.5 x 65
F063020	M30-3.5 x 70
F063022	M30-3.5 x 80
F063023	M30-3.5 x 90
F063024	M30-3.5 x 100
F063025	M30-3.5 x 110
F063026	M30-3.5 x 120
F063027	M30-3.5 x 130
F063028	M30-3.5 x 140
F063029	M30-3.5 x 150
F063030	M30-3.5 x 160
F063031	M30-3.5 x 170
F063032	M30-3.5 x 180
F063033	M30-3.5 x 190
F063034	M30-3.5 x 200
F063035	M30-3.5 x 210
F063036	M30-3.5 x 220
F063037	M30-3.5 x 240
F063038	M30-3.5 x 260
F063040	M30-3.5 x 300
F063041	M30-3.5 x 320
F063622	M36-4.0 x 80
F063623	M36-4.0 x 90
F063624	M36-4.0 x 100
F063626	M36-4.0 x 120
F063627	M36-4.0 x 130
F063628	M36-4.0 x 140
F063629	M36-4.0 x 150
F063630	M36-4.0 x 160
F063631	M36-4.0 x 170
F063634	M36-4.0 x 200

A  
B

# SOCKET SET SCREW

(F21, F22 & F23 SERIES)

GLOBAL STANDARD COMPONENTS



Assembly

05/14/97

## NOTES & SPECIFICATIONS:

ANSI B18.3.6M  
CLASS 45H  
See individual point styles  
for applicable DIN and ISO  
specifications  
(See next page)

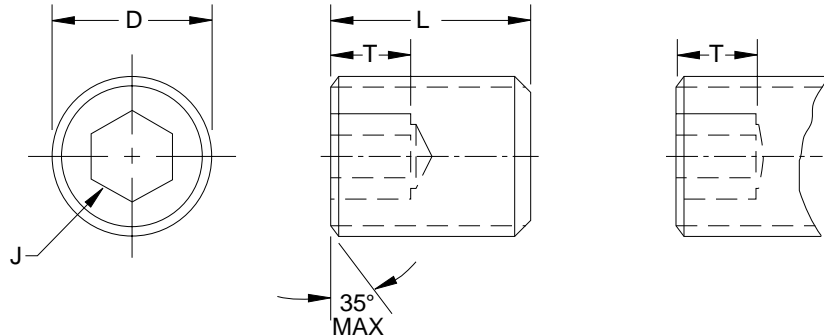

A

B

NAAMS CODE FLAT POINT STYLE	NAAMS CODE CONE POINT STYLE	NAAMS CODE CUP POINT (TYPE 1) STYLE	D NOMINAL SIZE OF BASIC SCREW $\phi$ x PITCH	J HEXAGON SOCKET SIZE NOM.	L NOMINAL SCREW LENGTHS	T FOR CUP AND FLAT POINTS MIN
F210503	F220503	F230503			3	1.2
F210504	F220504	F230504			4	2.0
F210505	F220505	F230505	5 x 0.8	2.5	5	2.7
F210506	F220506	F230506			6	2.7
F210508	F220508	F230508			8	2.7
F210604	F220604	F230604			4	1.8
F210605	F220605	F230605	6 x 1	3	5	2.5
F210606	F220606	F230606			6	3.0
F210608	F220608	F230608			8	3.0
F210805	F220805	F230805			5	1.8
F210806	F220806	F230806	8 x 1.25	4	6	2.5
F210808	F220808	F230808			8	4.0
F210810	F220810	F230810			10	4.0
F211006	F221006	F231006			6	2.0
F211008	F221008	F231008	10 x 1.5	5	8	3.6
F211010	F221010	F231010			10	5.0
F211012	F221012	F231012			12	5.0
F211208	F221208	F231208			8	3.0
F211210	F221210	F231210	12 x 1.75	6	10	4.5
F211212	F221212	F231212			12	6.0
F211216	F221216	F231216			16	6.0
F211610	F221610	F231610			10	3.0
F211612	F221612	F231612	16 x 2	8	12	4.8
F211616	F221616	F231616			16	8.0
F211620	F221620	F231620			20	8.0
F212012	F222012	F232012			12	-
F212016	F222016	F232016	20 x 2.5	10	16	6.0
F212020	F222020	F232020			20	9.0
F212025	F222025	F232025			25	10.0
F212416	F222416	F232416			16	5.0
F212420	F222420	F232420			20	8.0
F212425	F222425	F232425	24 x 3	12	25	12.0
F212430	F222430	F232430			30	12.0

# SOCKET SET SCREW POINT STYLES

(F21, F22 & F23 SERIES)

Assembly

05/14/97

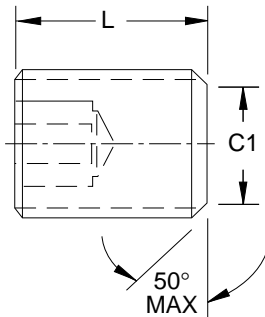

**FLAT POINT  
(F21)**

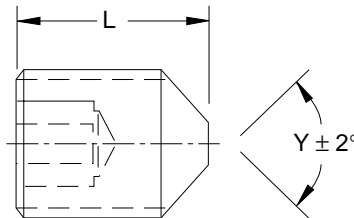

**CONE POINT  
(F22)**

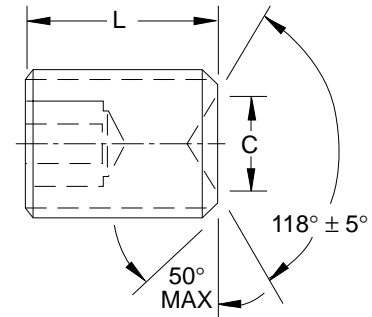

**CUP POINT  
TYPE 1 (F23)**

D NOMINAL SIZE OF BASIC SCREW ∅	C CUP POINT ∅ TYPE 1		C1 FLAT POINT ∅		Y CONE POINT ANGLE 90° FOR THESE LENGTHS AND OVER; 118° FOR SHORTER LENGTHS
	MAX	MIN	MAX	MIN	
5	2.50	2.25	3.50	3.20	6
6	3.00	2.75	4.00	3.70	8
8	5.00	4.70	5.50	5.20	10
10	6.00	5.70	7.00	6.64	12
12	8.00	7.64	8.50	8.14	16
16	10.00	9.64	12.00	11.57	20
20	14.00	13.57	15.00	14.57	25
24	16.00	15.57	18.00	17.57	30

**NOTES & SPECIFICATIONS:**

Material hardness 45H  
Must conform to:  
ANSI B18.3.6M  
Thread class 4g 6g

Cup Point - DIN 916, ISO 4029, ANSI B18.3.6M  
Flat Point - DIN 913, ISO 4026, ANSI B18.3.6M  
Cone Point - DIN 914, ISO 4027, ANSI B18.3.6M

**A**

**B**

**C**

# HEXAGON NUT

(FINE: F39 SERIES)

GLOBAL STANDARD COMPONENTS



Assembly

07/25/08

B

## FINE THREADS

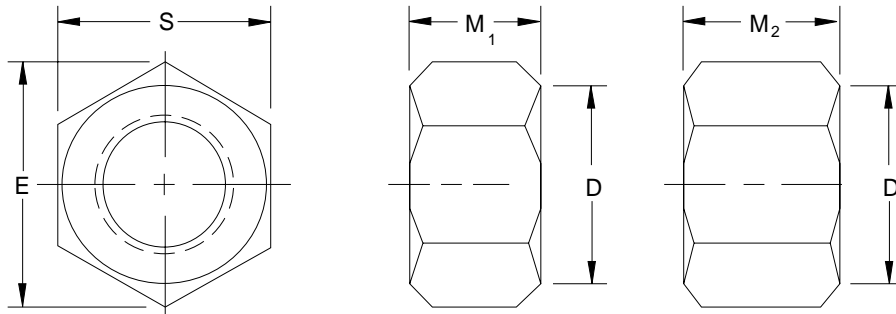

STYLE 1

STYLE 2

NAAMS CODE	NOMINAL NUT $\phi$ & THREAD PITCH	S WIDTH ACROSS FLATS		E WIDTH ACROSS CORNERS		M <sub>1</sub> THICKNESS ANSI B18.2.4.1M		M <sub>2</sub> THICKNESS ANSI B18.2.4.2M		D BEARING FACE $\phi$
		MAX	MIN	MAX	MIN	MAX	MIN	MAX	MIN	MIN
F392436	M24 x 2	36.00	35.00	41.57	39.55	23.90	22.60	23.90	22.60	33.2

NOTE: F41 SERIES WAS DISCONTINUED 09/18/1998

C

### NOTES & SPECIFICATIONS:

F41 SERIES DISCONTINUED  
 ASTM A563M  
 Class 12

D

# HEXAGON NUT WASHER FACE

(F42 SERIES)

GLOBAL STANDARD COMPONENTS

TM **NAAMS**



Assembly

07/25/08

## COARSE THREAD

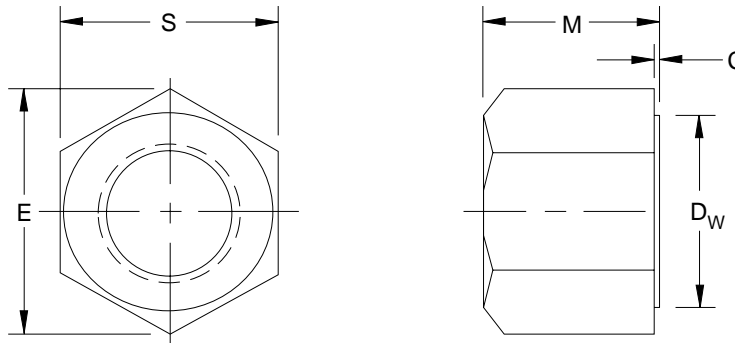

NAAMS CODE	NOMINAL NUT $\phi$ & THREAD PITCH	S WIDTH ACROSS FLATS		E WIDTH ACROSS CORNERS		M THICKNESS ANSI B18.2.4.2M		D <sub>w</sub> BEARING FACE $\phi$	C WASHER FACE THICKNESS	
		MAX	MIN	MAX	MIN	MAX	MIN	MIN	MAX	MIN
F420508	M5 x 0.8	8.00	7.78	9.24	8.79	5.10	4.80	6.9	-	-
F420610	M6 x 1	10.00	9.78	11.55	11.05	5.70	5.40	8.9	-	-
F420813	M8 x 1.25	13.00	12.73	15.01	14.38	7.50	7.14	11.6	-	-
F421016	M10 x 1.5	16.00	15.73	18.48	17.77	9.30	8.94	14.6	-	-
F421218	M12 x 1.75	18.00	17.73	20.78	20.03	12.00	11.57	16.6	-	-
F421624	M16 x 2	24.00	23.67	27.71	26.75	16.40	15.70	22.5	-	-
F422030	M20 x 2.5	30.00	29.16	34.64	32.95	20.30	19.00	27.7	0.8	0.4
F422436	M24 x 3	36.00	35.00	41.57	39.55	23.90	22.60	33.2	0.8	0.4
F423046	M30 x 3.5	46.00	45.00	53.12	50.85	28.60	27.30	42.7	0.8	0.4
F423655	M36 x 4	55.00	53.80	63.51	60.79	34.70	33.10	51.1	0.8	0.4

### NOTES & SPECIFICATIONS:

ANSI B18.2.4.2M  
ASTM A563M  
Class 12

A

B

C



# HEXAGON JAM NUT

(FINE: F45 SERIES, COARSE: F47 SERIES)

GLOBAL STANDARD COMPONENTS



Assembly

07/25/08

## COARSE & FINE THREADS

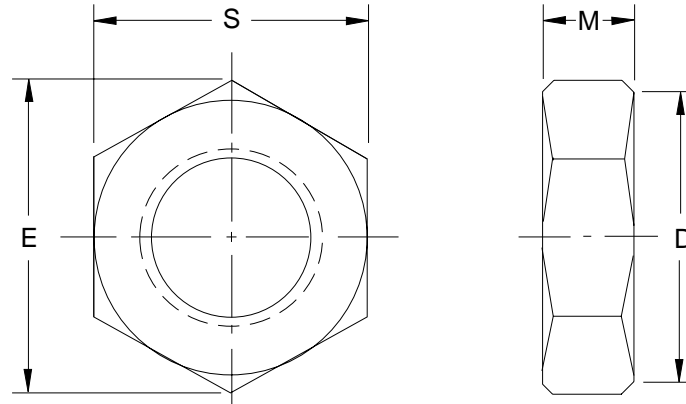

NAAMS CODE	NOMINAL NUT $\phi$ & THREAD PITCH	S WIDTH ACROSS FLATS		E WIDTH ACROSS CORNERS		M THICKNESS		D BEARING FACE $\phi$
		MAX	MIN	MAX	MIN	MAX	MIN	MIN
F451017	M10 x 1.25	17	-	-	-	5	-	-
F451219	M12 x 1.25	19	-	-	-	6	-	-
F451624	M16 x 1.5	24	-	-	-	8	-	-
F452030	M20 x 1.5	30	-	-	-	10	-	-
F452436	M24 x 2	36	-	-	-	13.5	-	-
F452741	M27 x 2	41	-	-	-	13.5	-	-
F453650	M36 x 2	50	-	-	-	16	-	-
F470508	M5 x 0.8	8.00	7.78	9.24	8.79	2.70	2.45	6.9
F470610	M6 x 1	10.00	9.78	11.55	11.05	3.20	2.90	8.9
F470813	M8 x 1.25	13.00	12.73	15.01	14.38	4.00	3.70	11.6
F471016	M10 x 1.5	16.00	15.73	18.48	17.77	5.00	4.70	14.6
F471218	M12 x 1.75	18.00	17.73	20.78	20.03	6.00	5.70	16.6
F471624	M16 x 2	24.00	23.67	27.71	26.75	8.00	7.42	22.5
F472030	M20 x 2.5	30.00	29.16	34.64	32.95	10.00	9.10	27.7
F472436	M24 x 3	36.00	35.00	41.57	39.55	12.00	10.90	33.2
F473046	M30 x 3.5	46.00	45.00	53.12	50.85	15.00	13.90	42.7
F473655	M36 x 4	55.00	53.80	63.51	60.79	18.00	16.90	51.1

### NOTES & SPECIFICATIONS:

ANSI B18.2.4.5M  
ASTM A563M  
CLASS 04

D

C

B

A

E

# HEXAGON JAM NUT WITH WASHER FACE

(FINE: F46 SERIES COARSE: F48 SERIES)

GLOBAL STANDARD COMPONENTS



Assembly

07/25/08

## COARSE & FINE THREADS

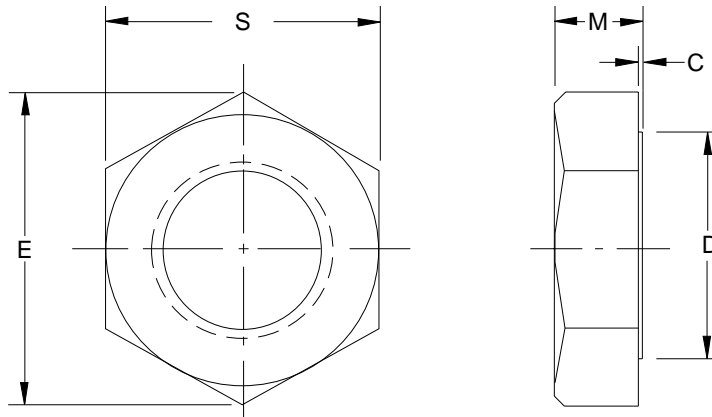

NAAMS CODE	NOMINAL NUT $\phi$ & THREAD PITCH	S WIDTH ACROSS FLATS		E WIDTH ACROSS CORNERS		M THICKNESS		D BEARING FACE $\phi$	C WASHER FACE THICKNESS	
		MAX	MIN	MAX	MIN	MAX	MIN	MIN	MAX	MIN
F480508	M5 x 0.8	8.00	7.78	9.24	8.79	2.70	2.45	6.9	-	-
F480610	M6 x 1	10.00	9.78	11.55	11.05	3.20	2.90	8.9	-	-
F480813	M8 x 1.25	13.00	12.73	15.01	14.38	4.00	3.70	11.6	-	-
F461017	*M10 x 1.25	17	-	-	-	5	-	-	-	-
F481016	M10 x 1.5	16.00	15.73	18.48	17.77	5.00	4.70	14.6	-	-
F461219	*M12 x 1.25	19	-	-	-	6	-	-	-	-
F481218	M12 x 1.75	18.00	17.73	20.78	20.03	6.00	5.70	16.6	-	-
F461624	*M16 x 1.5	24	-	-	-	8	-	-	-	-
F481624	M16 x 2	24.00	23.67	27.71	26.75	8.00	7.42	22.5	-	-
F462030	*M20 x 1.5	30	-	-	-	10	-	-	-	-
F482030	M20 x 2.5	30.00	29.16	34.64	32.95	10.00	9.10	27.7	0.8	0.4
F482436	M24 x 3	36.00	35.00	41.57	39.55	12.00	10.90	33.2	0.8	0.4
F462741	*M27 x 2	41	-	-	-	13.5	-	-	-	-
F483046	M30 x 3.5	46.00	45.00	53.12	50.85	15.00	13.90	42.7	0.8	0.4
F463650	*M36 x 2	50	-	-	-	16	-	-	-	-
F483655	M36 x 4	55.00	53.80	63.51	60.79	18.00	16.90	51.1	0.8	0.4

\* Fine thread series (F46 Series)

### NOTES & SPECIFICATIONS:

ANSI B18.2.4.5M  
ASTM A563M  
Class 04

A

B

C

# HARDENED WASHER

(F62 SERIES)

GLOBAL STANDARD COMPONENTS

# NAAMS



Assembly

07/25/08

(ASTM F436M)

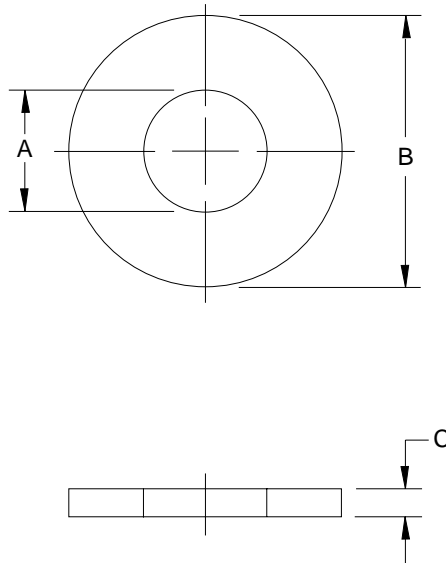

NAAMS CODE	NOMINAL WASHER	A INSIDE $\phi$		B OUTSIDE $\phi$		C THICKNESS	
		MAX	MIN	MAX	MIN	MAX	MIN
F620614	6	7.3	7.0	13.6	12.6	4.0	2.7
F620818	8	9.8	9.0	18.4	17.1	4.0	2.7
F621022	10	11.8	11.0	22.0	20.7	4.0	2.7
F621025*	10	10.8	10.2	25.3	24.7	5.0	4.0
F621227	12	14.4	14.0	27.0	25.7	4.6	3.1
F621634	16	18.4	18.0	34.0	32.4	4.6	3.1
F622042	20	22.5	22.0	42.0	40.4	4.6	3.1
F622244	22	24.5	24.0	44.0	42.4	4.6	3.4
F622450	24	26.5	26.0	50.0	48.4	4.6	3.4
F622756	27	30.5	30.0	56.0	54.1	4.6	3.4
F623060	30	33.6	33.0	60.0	58.1	4.6	3.4
F623672	36	39.6	39.0	72.0	70.1	4.6	3.4

\*Special purpose for locating pin retainer assemblies  
1020 H.R.S. carb & harden 1.0 deep 38-45 Rc

### NOTES & SPECIFICATIONS:

M6-M10 – Rc 38-45 through hardened (except as noted)

M12 & larger – ASTM F436M

C

A

B

D

# PULL DOWEL PIN

(F91 SERIES)

GLOBAL STANDARD COMPONENTS



Assembly

07/25/08

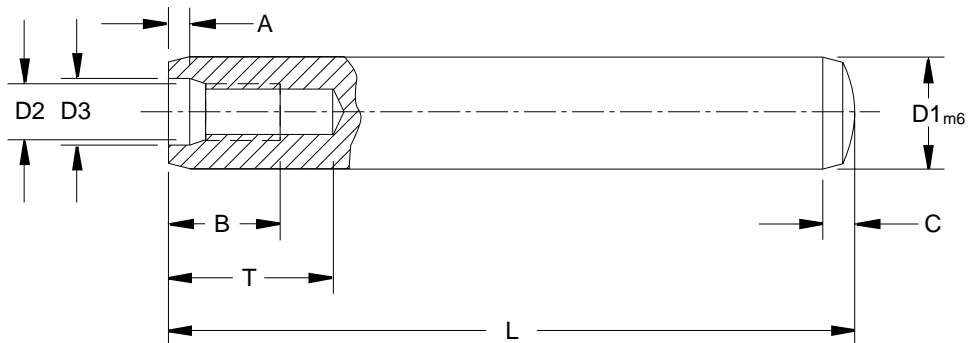

D1 Dia.	6	8	10	12	16	20	25	
<b>C</b>	2.1	2.6	3	3.8	4.6	6	6	
<b>D2 MAX.</b>	M4 X 0.7	M5 x 0.8	M6 x 1	M6 x 1	M8 x 1.25	M10 x 1.5	M16 x 2	
<b>B</b>	6	8	10	12	16	18	24	
<b>D3</b>	4.3	5.3	6.4	6.4	8.4	10.5	17	
<b>A</b>	1	1.2	1.2	1.2	1.5	1.5	2	
<b>T MIN.</b>	10	12	16	20	25	28	35	
<b>L</b>	16	X						
	20	X	X					
	24	X	X	X				
	28	X	X	X	X			
	32	X	X	X	X	X		
	40	X	X	X	X	X	X	
	50	X	X	X	X	X	X	X
	60	X	X	X	X	X	X	X
	70		X	X	X	X	X	X
	80		X	X	X	X	X	X
	90			X	X	X	X	X
	100			X	X	X	X	X
120				X	X	X	X	

## NOTES & SPECIFICATIONS:

- Material, case hardened alloy steel – shear strength: 825 MPa (120ksi)
- ANSI B18.8.5M
- Precision ground
- Provide for air release (e.g., machine a flat, spiral, etc.)

CODING ON FOLLOWING PAGE

A

B

C

# PULL DOWEL PIN CODING

(F91 SERIES)

GLOBAL STANDARD COMPONENTS



Assembly

07/25/08

NAAMS CODE	NOM. SIZE, AND LENGTH	NOTES
F910616	6x16	
F910620	6x20	
F910624	6x24	DISCONTINUED
F910625	6x25	
F910628	6x28	DISCONTINUED
F910630	6x30	
F910632	6x32	DISCONTINUED
F910635	6x35	
F910640	6x40	
F910650	6x50	
F910660	6x60	
F910820	8x20	
F910824	8x24	DISCONTINUED
F910825	8x25	
F910828	8x28	DISCONTINUED
F910830	8x30	
F910832	8x32	DISCONTINUED
F910835	8x35	
F910840	8x40	
F910850	8x50	
F910860	8x60	
F910870	8x70	
F910880	8x80	
F911024	10x24	DISCONTINUED
F911025	10x25	
F911028	10x28	DISCONTINUED
F911030	10x30	
F911032	10x32	DISCONTINUED
F911035	10x35	
F911040	10x40	
F911050	10x50	
F911060	10x60	
F911070	10x70	
F911080	10x80	
F911090	10x90	
F911010	10x100	
F911228	12x28	DISCONTINUED
F911230	12x30	
F911232	12x32	DISCONTINUED
F911235	12x35	
F911240	12x40	
F911250	12x50	

NAAMS CODE	NOM. SIZE, AND LENGTH	NOTES
F911260	12x60	
F911270	12x70	
F911280	12x80	
F911290	12x90	
F911210	12x100	
F911212	12x120	
F911632	16x32	DISCONTINUED
F911635	16x35	
F911640	16x40	
F911650	16x50	
F911660	16x60	
F911670	16x70	
F911680	16x80	
F911690	16x90	
F911610	16x100	
F911612	16x120	
F912040	20x40	
F912050	20x50	
F912060	20x60	
F912070	20x70	
F912080	20x80	
F912090	20x90	
F912010	20x100	
F912012	20x120	
F912550	25x50	
F912560	25x60	
F912570	25x70	
F912580	25x80	
F912590	25x90	
F912510	25x100	
F912512	25x120	

A  
B

**PREFERRED METRIC  
FASTENER SIZES**

**CHARTS / TEXT MOVED TO PAGE F - 2.3**

C