

PUNCHES/DIE BUTTONS & COMPONENTS INDEX

PAGE	DATE	SERIES	DESCRIPTION
P-1	02/08/24		Punches/Die Buttons & Components Index
P-2	03/09/22		Punches/Die Buttons & Components Index
P-3	03/09/22		Punches/Die Buttons & Components Index
P-3.1	02/08/24		Punches/Die Buttons & Components Index
P-4	04/02/98		Ordering Examples
P-5	03/09/22	P01	Ball Lock Punch Retainer
P-6	04/01/21	DISCONTINUED	Ball Lock Punch Change Retainer
P-7	03/09/22	P02 & P03	Backing and Retaining Plate Set
P-8	03/09/22	P04	Headed Urethane Punch Stripper
P-9	12/14/21		Blank Page
P-10	04/02/98		Alternate Ball Seat Locations
P-11	04/24/14	P10, P11 & P12	Round Ball Lock Punch (Heavy Duty)
P-12	04/16/96	P10, P11 & P12	Round Ball Lock Punch Coding (Heavy Duty)
P-13	04/24/14	P20, P21 & P22	Oblong Ball Lock Punch (Heavy Duty)
P-14	04/16/96	P20, P21 & P22	Oblong Ball Lock Punch Coding (Heavy Duty)
P-15	04/24/14	P30, P31 & P32	Square Ball Lock Punch (Heavy Duty)
P-16	04/16/96	P30, P31 & P32	Square Ball Lock Punch Coding (Heavy Duty)
P-17	04/25/14	P40, P41 & P42	Rectangular Ball Lock Punch (Heavy Duty)
P-18	04/16/96	P40, P41 & P42	Rectangular Ball Lock Punch Coding (Heavy Duty)
P-19	04/24/14	P15, P16 & P17	Round Ball Lock Ejector Punch (heavy Duty)
P-20	04/16/96	P15, P16 & P17	Round Ball Lock Ejector Punch Coding (Heavy Duty)
P-21	04/24/14	P25, P26 & P27	Oblong Ball Lock Ejector Punch (Heavy Duty)
P-22	04/16/96	P25, P26 & P27	Oblong Ball Lock Ejector Punch Coding (Heavy Duty)
P-23	04/24/14	P35, P36 & P37	Square Ball Lock Ejector Punch (Heavy Duty)
P-24	04/16/96	P35, P36 & P37	Square Ball Lock Ejector Punch Coding (Heavy Duty)
P-25	04/24/14	P45, P46 & P47	Rectangular Ball Lock Ejector Punch (Heavy Duty)
P-26	04/16/96	P45, P46 & P47	Rectangular Ball Lock Ejector Punch Coding (Heavy Duty)
P-27	07/26/99	P55, P56 & P57	Ball Lock Pilot Punch (Heavy Duty)
P-28	07/26/99	P55, P56 & P57	Ball Lock Pilot Punch Coding (Heavy Duty)
P-29	04/24/14	P60, P61 & P62	Straight Relief, Round Die Button Press Fit, Dowel Slot Locking Device
P-30	04/16/96	P60	Straight Relief, Round Die Button Press Fit, Dowel Slot Locking Device Coding
P-31	04/16/96	P61	Straight Relief, Round Die Button Press Fit, Dowel Slot Locking Device Coding

PUNCHES/DIE BUTTONS & COMPONENTS INDEX

PAGE	DATE	SERIES	DESCRIPTION
P-32	04/16/96	P62	Straight Relief, Round Die Button Press Fit, Dowel Slot Locking Device Coding
P-33	04/24/14	P70, P71 & P72	Straight Relief, Oblong Die Button Press Fit, Dowel Slot Locking Device
P-34	04/16/96	P70	Straight Relief, Oblong Die Button Press Fit, Dowel Slot Locking Device Coding
P-35	04/16/96	P71	Straight Relief, Oblong Die Button Press Fit, Dowel Slot Locking Device Coding
P-36	04/16/96	P72	Straight Relief, Oblong Die Button Press Fit, Dowel Slot Locking Device Coding
P-37	04/24/15	P80, P81 & P82	Straight Relief, Square Die Button Press Fit, Dowel Slot Locking Device
P-38	04/16/96	P80	Straight Relief, Square Die Button Press Fit, Dowel Slot Locking Device Coding
P-39	04/16/96	P81	Straight Relief, Square Die Button Press Fit, Dowel Slot Locking Device Coding
P-40	04/16/96	P82	Straight Relief, Square Die Button Press Fit, Dowel Slot Locking Device Coding
P-41	04/24/15	P90, P91 & P92	Straight Relief, Rectangular Die Button Press Fit, Dowel Slot Locking Device
P-42	04/16/96	P90	Straight Relief, Rectangular Die Button Press Fit, Dowel Slot Locking Device Coding
P-43	04/16/96	P91	Straight Relief, Rectangular Die Button Press Fit, Dowel Slot Locking Device Coding
P-44	04/16/96	P92	Straight Relief, Rectangular Die Button Press Fit, Dowel Slot Locking Device Coding
P-45	07/01/99	P64, P65, P66 & P67	Tapered Relief Round Die Button
P-46	04/16/96	P64 & P65	Tapered Relief Round Die Button Coding
P-47	04/16/96	P66	Tapered Relief Round Die Button
P-48	04/16/96	P67	Tapered Relief Round Die Button Coding
P-49	07/01/99	P75, P76 & P77	Tapered Relief Oblong Die Button
P-50	04/16/96	P75	Tapered Relief Oblong Die Button Coding
P-51	04/16/96	P76	Tapered Relief Oblong Die Button
P-52	04/16/96	P77	Tapered Relief Oblong Die Button Coding
P-53	07/01/99	P85, P86 & P87	Tapered Relief Square Die Button
P-54	04/16/96	P85	Tapered Relief Square Die Button Coding
P-55	04/16/97	P86	Tapered Relief Square Die Button Coding

PUNCHES/DIE BUTTONS & COMPONENTS INDEX

PAGE	DATE	SERIES	DESCRIPTION
P-56	04/16/96	P87	Tapered Relief Square Die Button Coding
P-57	07/01/99	P95, P96 & P97	Tapered Relief Rectangular Die Button
P-58	04/16/96	P95	Tapered Relief Rectangular Die Button Coding
P-59	04/16/96	P96	Tapered Relief Rectangular Die Button Coding
P-60	04/16/96	P97	Tapered Relief Rectangular Die Button Coding
P-61	05/14/97	P51, P52 & P53	Pierce and Extrude Ball Lock Punch (Heavy Duty)
P-62	05/14/97	P51, P52 & P53	Pierce and Extrude Ball Lock Punch (Heavy Duty) Coding
P-63	04/24/15	P13 & P14	Round Point Larger Ball Lock Punch (Heavy Duty)
P-64	10/30/96	P13 & P14	Round Point Larger Ball Lock Punch (Heavy Duty) Coding
P-65	04/24/14	P23 & P24	Oblong Point Larger Ball Lock Punch (Heavy Duty)
P-66	10/30/96	P23 & P24	Oblong Point Larger Ball Lock Punch (Heavy Duty) Coding
P-67	04/24/14	P33 & P34	Square Point Larger Ball Lock Punch (Heavy Duty)
P-68	10/30/96	P33 & P34	Square Point Larger Ball Lock Punch (Heavy Duty) Coding
P-69	04/24/14	P43 & P44	Rectangle Point Larger Ball Lock Punch (Heavy Duty)
P-70	10/30/96	P43 & P44	Rectangle Point Larger Ball Lock Punch (Heavy Duty) Coding
P-71	03/13/97	P18 & P19	Round Point Larger Ball Lock Ejector Punch (Heavy Duty)
P-72	10/30/96	P18 & P19	Round Point Larger Ball Lock Ejector Punch (Heavy Duty) Coding
P-73	05/14/97	P28 & P29	Oblong Point Larger Ball Lock Ejector Punch (Heavy Duty)
P-74	10/30/96	P28 & P29	Oblong Point Larger Ball Lock Ejector Punch (Heavy Duty) Coding
P-75	05/14/97	P38 & P39	Square Point Larger Ball Lock Ejector Punch (Heavy Duty)
P-76	10/30/96	P38 & P39	Square Point Larger Ball Lock Ejector Punch (Heavy Duty) Coding
P-77	05/14/97	P48 & P49	Rectangle Point Larger Ball Lock Ejector Punch (Heavy Duty)
P-78	10/30/96	P48 & P49	Rectangle Point Larger Ball Lock Ejector Punch (Heavy Duty) Coding
P-79	03/09/22	P05	Headed Urethane Punch Stripper
P-80	12/14/21		BLANK PAGE

PUNCHES/DIE BUTTONS & COMPONENTS INDEX

PAGE	DATE	SERIES	DESCRIPTION
P-81	10/20/10		Compact Ball Lock Punch Change Retainer Installation
P-82	10/20/10	P98	Compact Ball Lock Punch Change Retainer
P-83	10/20/10	P98	Compact Ball Lock Punch Change Retainer
P-84	10/20/10	P98	Ball Lock Punch Change Indicator
P-85	10/20/10	P98	Ball Lock Punch Change Indicator
P-86	10/20/10	P98	Pneumatic Distribution Block
P-87	03/09/22	P06	Snap-in Retainer for Headed Urethane Punch Stripper
P-88	02/08/24	P99	Special Urethane Punch Stripper with Radius Corners- Installation
P-89	02/08/24	P99	Special Urethane Punch Stripper with Radius Corners

Ordering Examples for Punches and Die Buttons Using NAAMS™ Code Numbers

The NAAMS code number is used to identify various punch and die button configurations. The punch code consists of a letter followed by numbers that indicate the type of product, the point length (straight before radius or SBR), the shank diameter and the overall length. The number is not complete enough to order a punch until the point size(s) is added. A round point is specified by adding "P" to the NAAMS number and next to the "P" the point size desired. In the case of a shape punch, "P" is added for the major dimension and a "W" for the minor dimension with the size desired for each. Die buttons are ordered in a similar manner. Standard ball seat location is 90°. For alternate locations add letters BS and degrees to callout.

Standard dowel slot location for matrixes is 0°. For alternate location add letters DS and degrees to call out. See examples or refer to page P-10 for drawings of alternate locations.

A

Examples of Round Punches

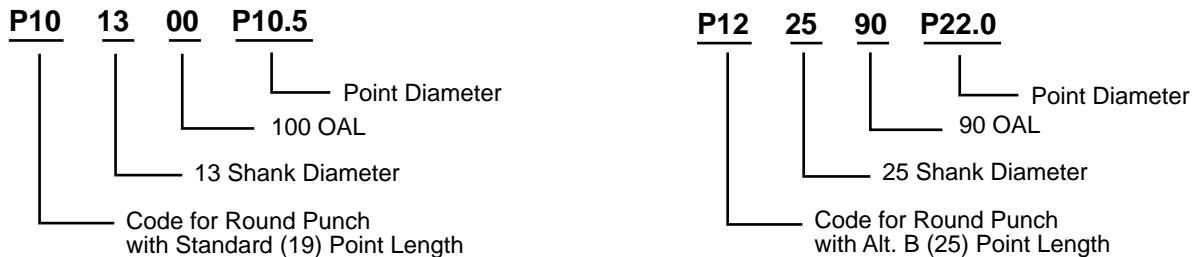

Examples of Shape Punches

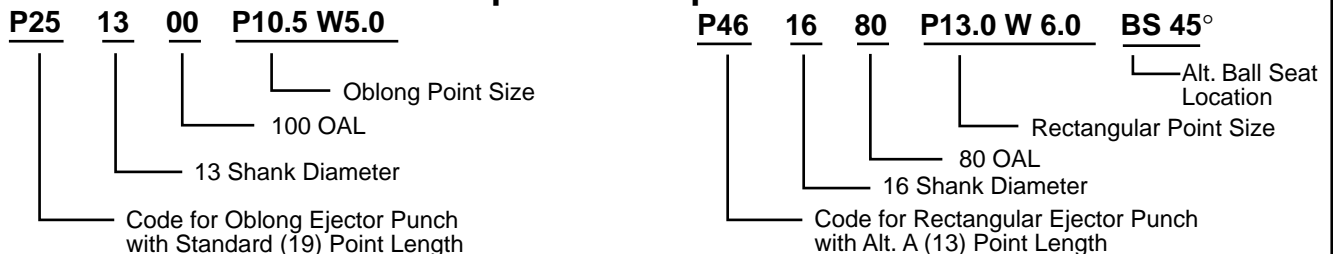

A

Examples of Die Buttons

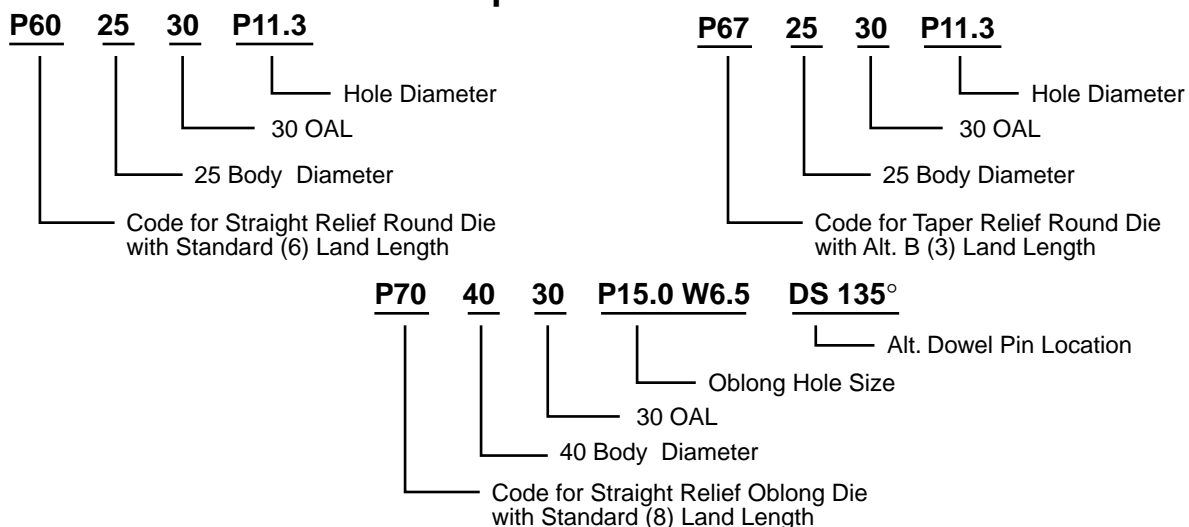

A

BALL LOCK PUNCH RETAINER

(P01 SERIES)

GLOBAL STANDARD COMPONENTS



Stamping

03/09/22

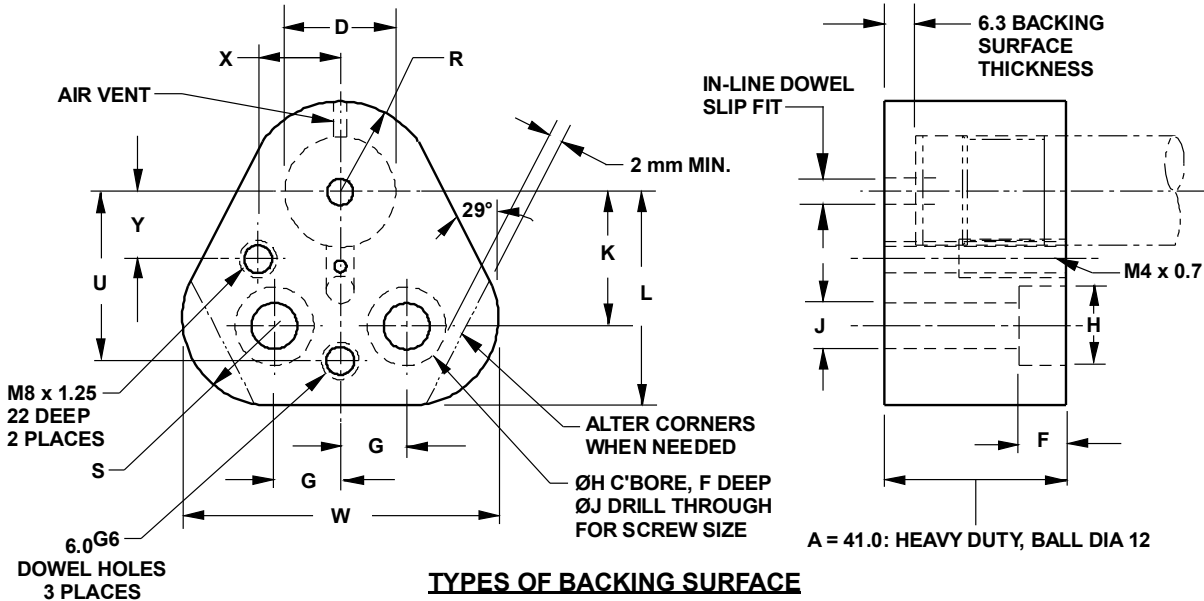

TYPES OF BACKING SURFACE

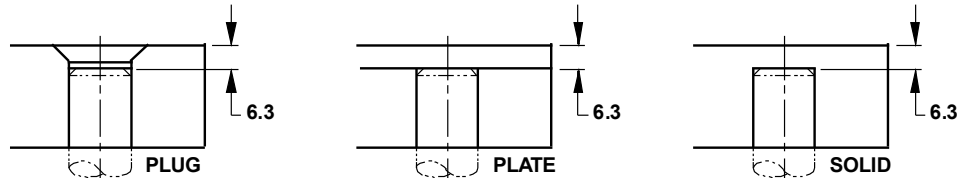

NAAMS CODE	D H6	A ±0.1	G ±0.13	F +0.40 -0.00	H +0.40 -0.00	J -0.25 +0.0	K ±0.13	L +0.8 -0.0	R max.	S -0.25 +0.0	U ±0.01	W +0.8 -0.0	X ±0.01	Y ±0.01	Screw Size
P010010	10 *	41.0	11.1	9.5	14.0	9.0	19.0	35.0	9.5	12.0	26.92	43.7	9.0	7.5	M8
P010013	13	41.0	14.3	9.5	14.0	9.0	19.0	38.1	12.7	15.2	29.97	50.0	12.0	6.5	M8
P010016	16	41.0	15.9	9.5	14.0	9.0	19.0	39.7	14.3	16.8	31.75	53.2	13.5	6.0	M8
P010020	20	41.0	17.5	11.5	17.0	11.0	19.0	42.8	17.5	20.0	33.53	59.5	16.5	5.0	M10
P010025	25	41.0	19.8	13.5	20	13.5	23.8	47.7	22.2	24.7	40.64	69.1	22.0	7.0	M12
P010032	32	41.0	19.8	13.5	20	13.5	23.8	47.7	22.2	24.7	40.64	69.1	22.0	7.0	M12
P010040	40	41.0	24.0	13.5	20	13.5	27.0	51.4	26.0	28.5	43.99	76.7	26.0	10.0	M12

* 10 mm BALL

NOTES & SPECIFICATIONS:

MATERIAL: ISO 683/ 14 51CrV4
RETAINER HARDNESS Rc 54-56
PLUG BACKING PLATE ISO 4957 X100 CrMoV5

- Break all edges.
 - Mark with NAAMS code and manufacturer's logo.
 - Ball lock punch retainer sets include screws and dowels.
- Backing surface must be a steel, plug, plate or solid.
 Slightly different configurations may be ordered from various punch manufacturers.
 Consult manufacturers catalogs.

BALL LOCK PUNCH CHANGE RETAINER

(P01 SERIES)

Stamping

04/01/21

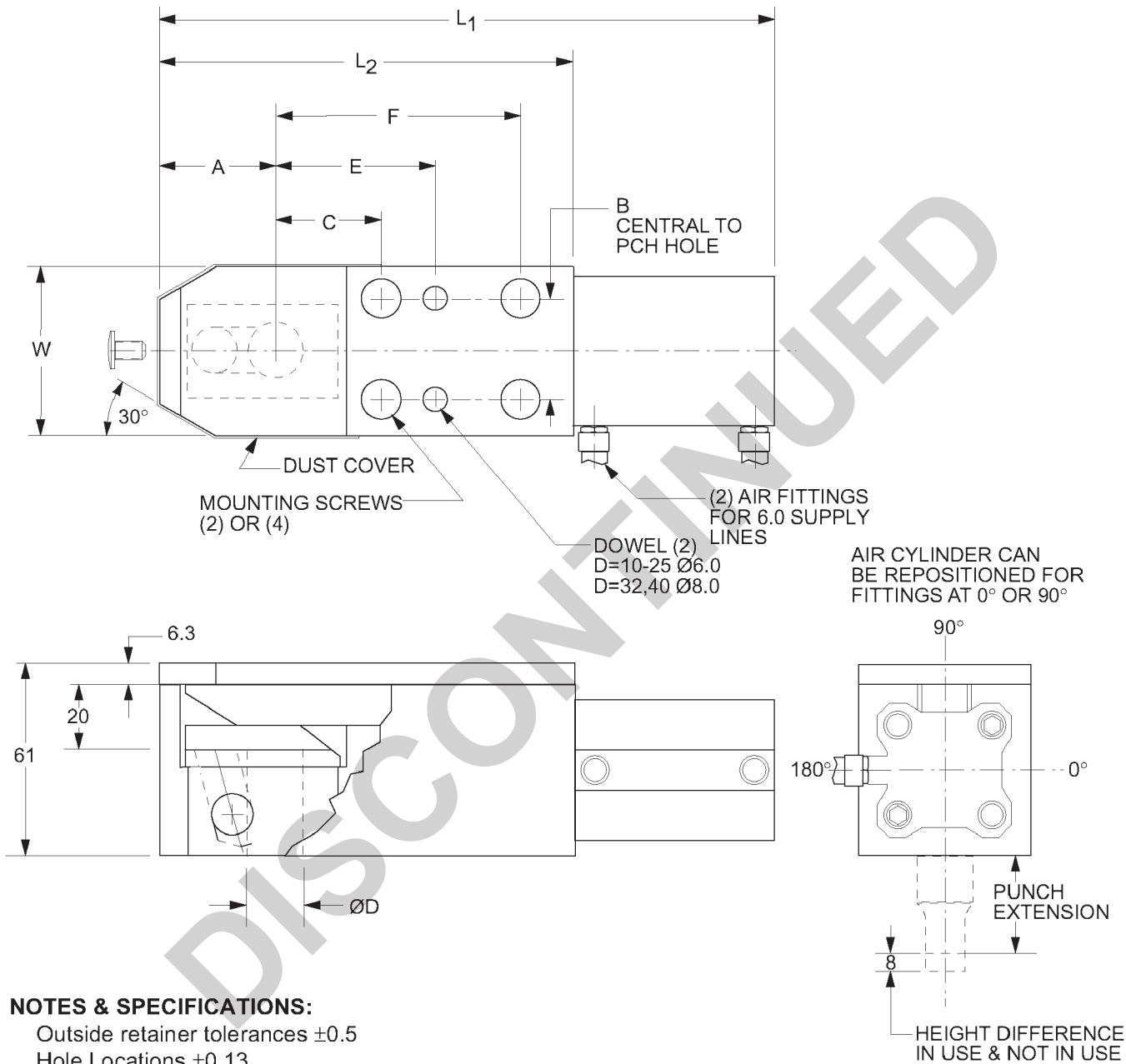

NAAMS CODE	MOUNTING SCREW	DOWEL	D Ø H6	W	L ₁	L ₂	A	B	C	E	F
P010510	M8 x 80	6 x 30	10	46	172	114	32	30	21	37	–
P010513	M10 x 80	6 x 30	13	50	183	120	34	30	25	41	–
P010516	M10 x 80	6 x 30	16	50	183	120	34	30	25	41	–
P010520	M10 x 80	6 x 30	20	58	204	136	37	38	29	45	–
P010525	M10 x 80	6 x 30	25	58	204	136	37	38	29	45	–
P010532	M12 x 80	8 x 30	32	80	257	174	44	56	38	60	100
P010540	M12 x 80	8 x 30	40	80	257	174	44	56	38	60	100

BACKING & RETAINING PLATE SET

(P02 & P03 SERIES)

GLOBAL STANDARD COMPONENTS



Stamping

03/09/22

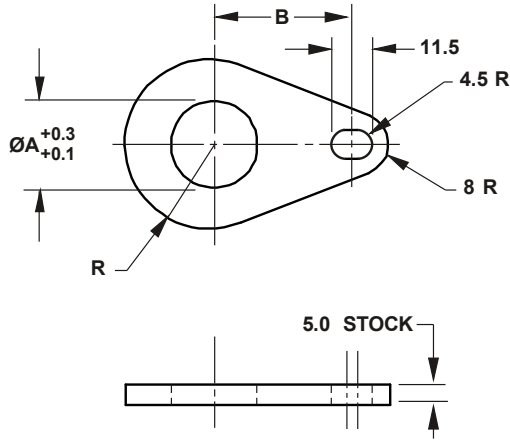

BACKING PLATE

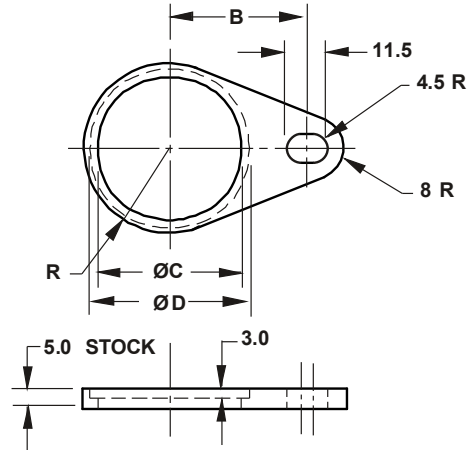

RETAINING PLATE

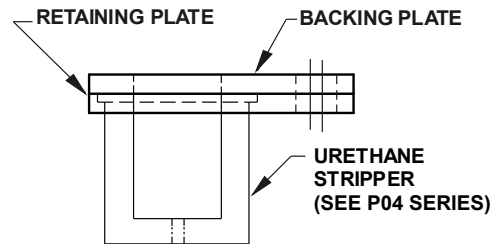

NAAMS CODE		A	B	C	D	R
BACKING PLATE	RETAINING PLATE					
P020010	P030010	10	28.0	19	22	13.0
P020013	P030013	13	31.0	24	27	15.5
P020016	P030016	16	32.9	29	32	18.0
P020020	P030020	20	34.8	34	37	20.5
P020025	P030025	25	39.8	41	44	24.0
P020032	P030032	32	41.3	51	56	31.0
P020040	P030040	40	45.0	61	66	36.0

NOTES & SPECIFICATIONS:

MATERIAL: ISO 683/18 - C20

- Break all edges.
- Mark with NAAMS code and manufacturer's logo.
- Use with P04 urethane punch stripper - See P-8

HEADED URETHANE PUNCH STRIPPER (P04 SERIES)

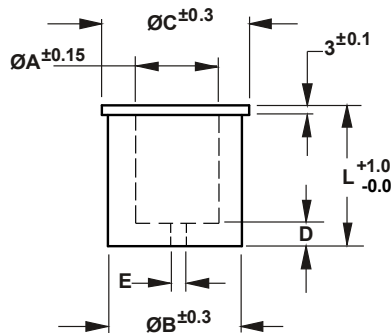

NAAMS CODE	PUNCH SHANK Ø	L +1.0/-0.0 STRIPPER LENGTH	DEFLECTIONS LOAD RATINGS IN NEWTONS			"A" PRESS FIT	B	C	D	"E" VENT HOLE
			3	6	9					
P041043	10	43	1060	1820	①	9.75	18	21	6	1.6
P041052		52	900	1650	2170					
P041063		63	720	1450	1860					
P041072		72	570	1280	1610					
P041343	13	43	1700	2850	①	12.75	23.5	26.3	6	3.0
P041352		52	1460	2610	3410					
P041363		63	1170	2320	2910					
P041372		72	930	2080	2500					
P041643	16	43	2310	3900	①	15.75	28.5	31.3	6	3.0
P041652		52	1990	3560	4640					
P041663		63	1590	3150	3980					
P041672		72	1270	2810	3440					
P042043	20	43	2900	4900	①	19.75	33.5	36.3	7	3.0
P042052		52	2500	4470	5820					
P042063		63	2000	3950	5000					
P042072		72	1590	3420	4330					
P042543	25	43	4440	7520	①	24.75	40.5	43.3	7	3.0
P042552		52	3810	6860	8780					
P042563		63	3050	6050	7680					
P042572		72	2420	5390	6780					
P043243	32	43	6840	11390	①	31.70	50.5	55.3	7	3.0
P043252		52	5880	10450	13300					
P043263		63	4700	9310	11640					
P043272		72	3740	8370	10280					
P044043	40	43	10100	20190	①	39.70	60.5	65.3	8	3.0
P044052		52	8650	17300	25960					
P044063		63	6890	13780	20670					

① 43 mm LONG STRIPPERS SHOULD NOT BE COMPRESSED MORE THAN 6.5 mm - MORE COMPRESSION EXCEEDS RECOMMENDED MAXIMUM OF 15%

NOTES & SPECIFICATIONS:

MATERIAL: POLYURETHANE - HARDNESS 95 +/- 5 SHORE A

- Mark with NAAMS code and manufacturer's logo.
- Use with P02 backing plate & P03 retaining plate - See P-7
- Use 52 mm length stripper for 90 mm punches.
- Stripper overall lengths will result in a 2-3 mm extension beyond punch point end of 80,90,100 and 110 mm OAL punch lengths.
- Punch point is to be pierced in urethane stripper before assembly.

Blank Page

A

**Data Removed.
Pages Left Blank For Future Use.**

ALTERNATE BALL SEAT LOCATIONS

A

Alternate Ball Seat Locations

The standard ball seat location for punches is at 90° counterclockwise from 0°. Other locations must be specified by adding the angle from 0° to the specification. Acceptable alternate locations are 0°, 45°, 135° for Ball Lock punches. See page P-4 for ordering examples.

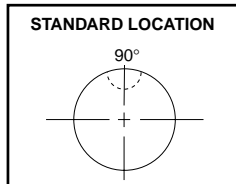

OBLONG PUNCHES

RECTANGULAR PUNCHES

SQUARE PUNCHES

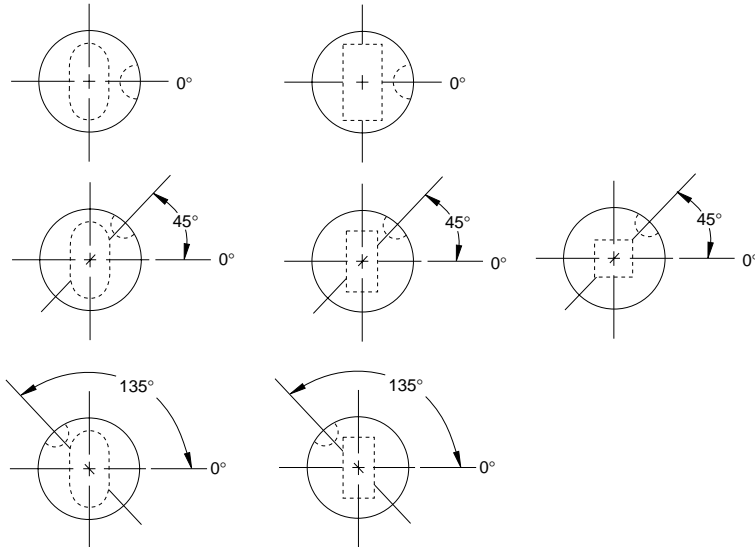

Alternate Dowel Slot Locations

The standard dowel slot for matrixes is at 0°. Other locations must be specified by adding the angle from 0° to the specification. Acceptable alternate locations are 45°, 90°, 135° for matrixes. See page P-4 for ordering examples.

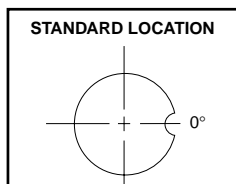

OBLONG MATRIXES

RECTANGULAR MATRIXES

SQUARE MATRIXES

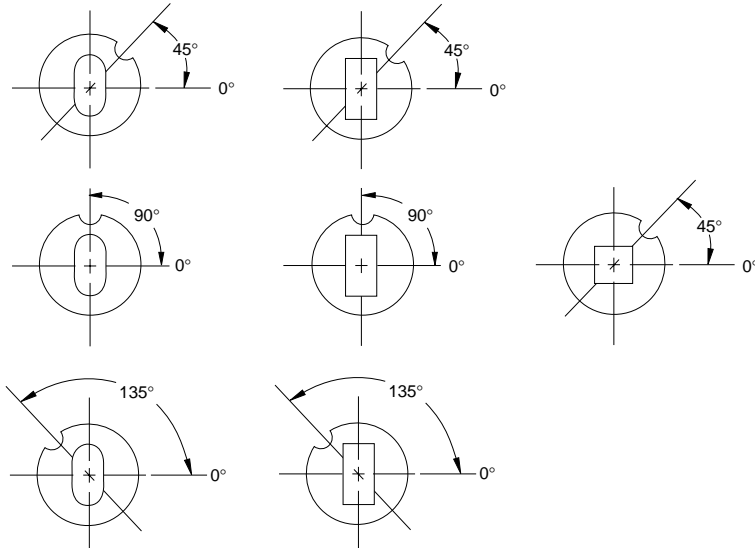

ROUND BALL LOCK PUNCH

(P10 THRU P12 SERIES)

GLOBAL STANDARD COMPONENTS



Stamping

04/24/14

(HEAVY DUTY)

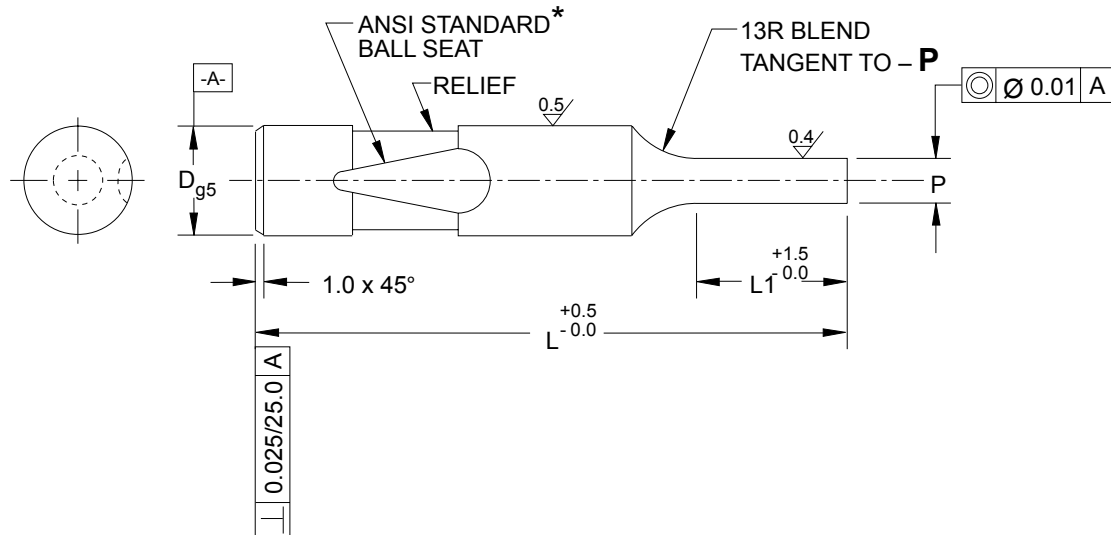

D NOMINAL SHANK Ø	P PUNCH POINTS AVAILABLE 0.01 INCREMENTS	L OVERALL LENGTH	L1 POINT LENGTH			PUNCH RETAINER NAAMS CODE	
			STD.	ALT A	ALT B		
10	2.5** to 9.8	80	19	10	—	P010010	
13	5.0 to 12.8		19	13	—	P010013	
16	8.0 to 15.8		19	13	25	P010016	
20	12.0 to 19.8	90	19	13	25	P010020	
25	16.0 to 24.8	100	19	13	25	P010025	
32	24.0 to 31.8		19	13	25	P010032	
40	30.0 to 39.8		25	19	30	30	P010040

NOTES & SPECIFICATIONS:

Material, AISI-M2.

Hardness, Rc 60-63. Triple temper.

Identification, etch the word "Metric" on each piece.

* Ball Seat must conform to ANSI Standard Gages for locking location.

** Minimum "P" is 1.5 for alternate point length "A".

CODING ON FOLLOWING PAGE

A

ROUND BALL LOCK PUNCH CODING

(P10 THRU P12 SERIES)

GLOBAL STANDARD COMPONENTS



Stamping

04/16/96

(HEAVY DUTY)

	Shape & Pnt. Length Style	Shank Dia.	O.A. Length	
EX: P11		10	80	= ALT. "A" ROUND x 10 SHANK x 80 LG.
P10		20	90	= STD. ROUND x 20 SHANK x 90 LG.

P10 = STD. ROUND
P11 = ALT. "A" ROUND
P12 = ALT. "B" ROUND

P10

NAAMS CODE	D x L
P101080	10 x 80
P101380	13 x 80
P101680	16 x 80
P102080	20 x 80
P102580	25 x 80
P103280	32 x 80
P104080	40 x 80
P101090	10 x 90
P101390	13 x 90
P101690	16 x 90
P102090	20 x 90
P102590	25 x 90
P103290	32 x 90
P104090	40 x 90
P101000	10 x 100
P101300	13 x 100
P101600	16 x 100
P102000	20 x 100
P102500	25 x 100
P103200	32 x 100
P104000	40 x 100

P11

NAAMS CODE	D x L
P111080	10 x 80
P111380	13 x 80
P111680	16 x 80
P112080	20 x 80
P112580	25 x 80
P113280	32 x 80
P114080	40 x 80
P111090	10 x 90
P111390	13 x 90
P111690	16 x 90
P112090	20 x 90
P112590	25 x 90
P113290	32 x 90
P114090	40 x 90
P111000	10 x 100
P111300	13 x 100
P111600	16 x 100
P112000	20 x 100
P112500	25 x 100
P113200	32 x 100
P114000	40 x 100

P12

NAAMS CODE	D x L
P121680	16 x 80
P122080	20 x 80
P122580	25 x 80
P123280	32 x 80
P124080	40 x 80
P121690	16 x 90
P122090	20 x 90
P122590	25 x 90
P123290	32 x 90
P124090	40 x 90
P121600	16 x 100
P122000	20 x 100
P122500	25 x 100
P123200	32 x 100
P124000	40 x 100

OBLONG BALL LOCK PUNCH

(P20 THRU P22 SERIES)

GLOBAL STANDARD COMPONENTS



Stamping

04/24/14

(HEAVY DUTY)

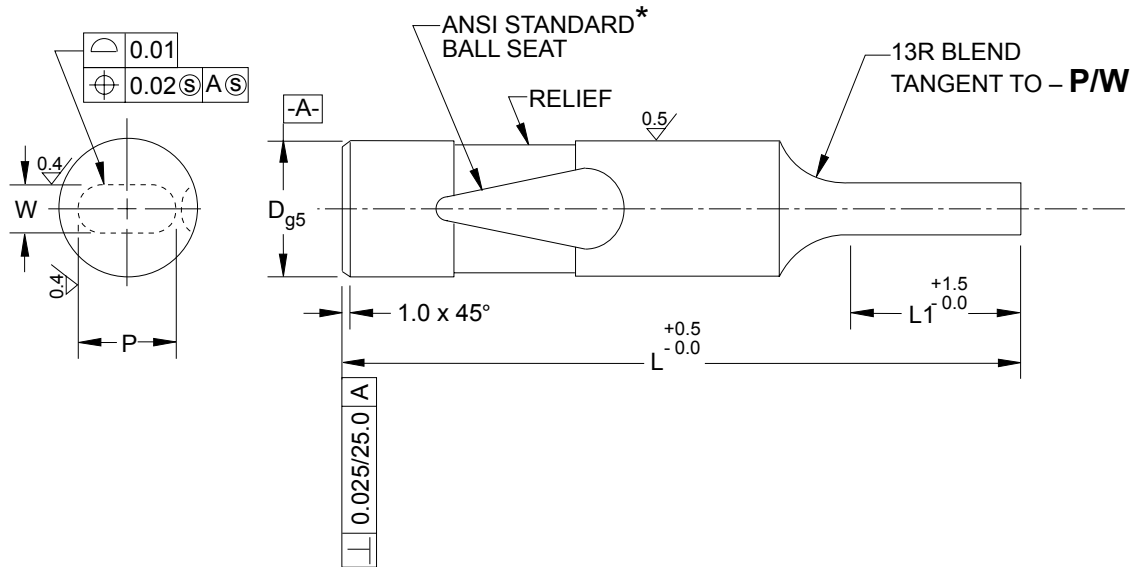

D NOMINAL SHANK Ø	PUNCH POINTS AVAILABLE 0.01 INCREMENTS		L OVERALL LENGTH	L1 POINT LENGTH			PUNCH RETAINER NAAMS CODE
	W MIN	P MAX		STD.	ALT A	ALT B	
10	2.5	9.8	80	19	10	–	P010010
13	5.0	12.8		19	13	–	P010013
16	6.0	15.8		19	13	25	P010016
20	8.0	19.8	90	19	13	25	P010020
25	10.0	24.8	100	19	13	25	P010025
32	11.5	31.8		19	13	25	P010032
40	14.0	39.8		19	13	25	P010032
				25	19	30	P010040

NOTES & SPECIFICATIONS:

Material, AISI-M2.

Hardness, Rc 60-63. Triple temper.

Identification, etch the word "Metric" on each piece.

* Ball Seat must conform to ANSI Standard gages for locking location. Functional axis of Ball Seat must be parallel to axis of punch shank within 0.025 per 50 mm on shape punches.

CODING ON FOLLOWING PAGE

A

OBLONG BALL LOCK PUNCH CODING

(P20 THRU P22 SERIES)

GLOBAL STANDARD COMPONENTS



Stamping

04/16/96

(HEAVY DUTY)

Shape & Pnt. Length Style	P20	Shank Dia.	32	O.A. Length	80
------------------------------	-----	------------	----	-------------	----

 = OBLONG, STD. PNT. x 32 SHANK x 80 LG.

P20 = STD. OBLONG
 P21 = ALT. "A" OBLONG
 P22 = ALT. "B" OBLONG

P20

NAAMS CODE	D x L
P201080	10 x 80
P201380	13 x 80
P201680	16 x 80
P202080	20 x 80
P202580	25 x 80
P203280	32 x 80
P204080	40 x 80
P201090	10 x 90
P201390	13 x 90
P201690	16 x 90
P202090	20 x 90
P202590	25 x 90
P203290	32 x 90
P204090	40 x 90
P201000	10 x 100
P201300	13 x 100
P201600	16 x 100
P202000	20 x 100
P202500	25 x 100
P203200	32 x 100
P204000	40 x 100

P21

NAAMS CODE	D x L
P211080	10 x 80
P211380	13 x 80
P211680	16 x 80
P212080	20 x 80
P212580	25 x 80
P213280	32 x 80
P214080	40 x 80
P211090	10 x 90
P211390	13 x 90
P211690	16 x 90
P212090	20 x 90
P212590	25 x 90
P213290	32 x 90
P214090	40 x 90
P211000	10 x 100
P211300	13 x 100
P211600	16 x 100
P212000	20 x 100
P212500	25 x 100
P213200	32 x 100
P214000	40 x 100

P22

NAAMS CODE	D x L
P221680	16 x 80
P222080	20 x 80
P222580	25 x 80
P223280	32 x 80
P224080	40 x 80
P221690	16 x 90
P222090	20 x 90
P222590	25 x 90
P223290	32 x 90
P224090	40 x 90
P221600	16 x 100
P222000	20 x 100
P222500	25 x 100
P223200	32 x 100
P224000	40 x 100

SQUARE BALL LOCK PUNCH

(P30 THRU P32 SERIES)

GLOBAL STANDARD COMPONENTS



Stamping

04/24/14

(HEAVY DUTY)

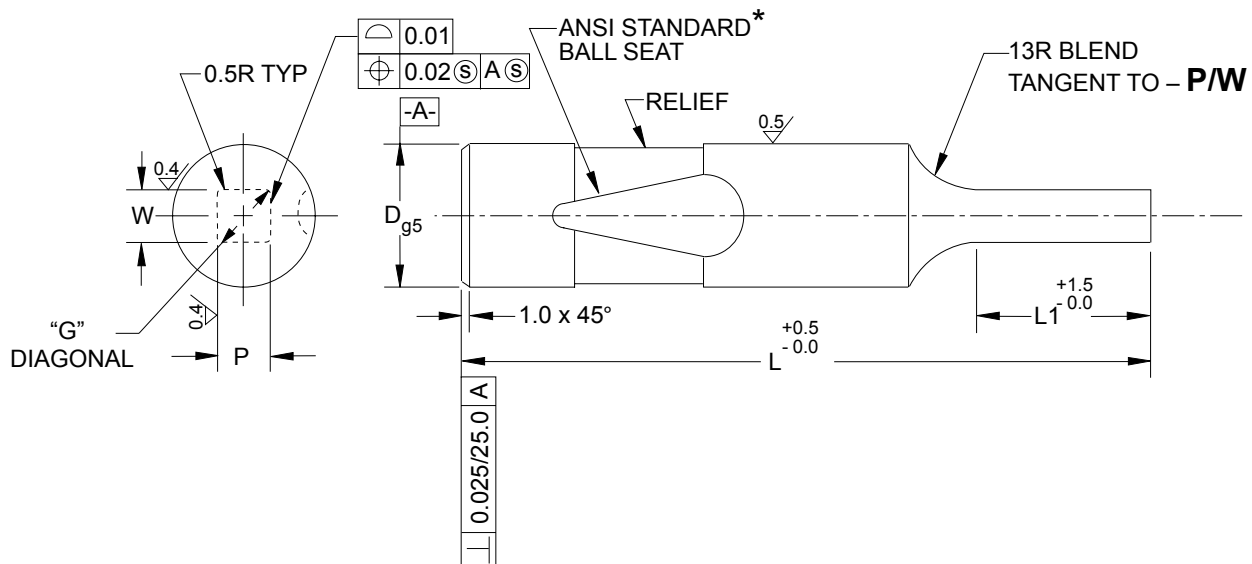

D NOMINAL SHANK Ø	POINTS AVAILABLE IN 0.01 INCREMENTS		L OVERALL LENGTH	L1 POINT LENGTH			PUNCH RETAINER NAAMS CODE
	W MIN	G MAX		STD.	ALT A	ALT B	
10	2.5	9.8	80	19	10	—	P010010
13	5.0	12.8		19	13	—	P010013
16	6.0	15.8		19	13	25	P010016
20	8.0	19.8		19	13	25	P010020
25	10.0	24.8		19	13	25	P010025
32	11.5	31.8		19	13	25	P010032
40	14.0	39.8		25	19	30	P010040

$$G = 2\sqrt{(P/2-R)^2 + (W/2-R)^2 + R}$$

NOTES & SPECIFICATIONS $G_{MAX} = D - 0.2$

Material, AISI-M2.

Hardness, Rc 60-63. Triple temper.

Identification, etch the word "Metric" on each piece.

* Ball Seat must conform to ANSI Standard gages for locking location. Functional axis of Ball Seat must be parallel to axis of punch shank within 0.025 per 50 mm on shape punches.

CODING ON FOLLOWING PAGE

A

SQUARE BALL LOCK PUNCH CODING

(P30 THRU P32 SERIES)

Stamping

04/16/96

(HEAVY DUTY)

EX:

Shape & Pnt. Length Style	P30
------------------------------	-----

Shank Dia.	32
------------	----

O.A. Length	80
-------------	----

 = SQUARE, STD. PNT. x 32 SHANK x 80 LG.

P30 = STD. SQUARE
 P31 = ALT. "A" SQUARE
 P32 = ALT. "B" SQUARE

P30

NAAMS CODE	D x L
P301080	10 x 80
P301380	13 x 80
P301680	16 x 80
P302080	20 x 80
P302580	25 x 80
P303280	32 x 80
P304080	40 x 80
P301090	10 x 90
P301390	13 x 90
P301690	16 x 90
P302090	20 x 90
P302590	25 x 90
P303290	32 x 90
P304090	40 x 90
P301000	10 x 100
P301300	13 x 100
P301600	16 x 100
P302000	20 x 100
P302500	25 x 100
P303200	32 x 100
P304000	40 x 100

P31

NAAMS CODE	D x L
P311080	10 x 80
P311380	13 x 80
P311680	16 x 80
P312080	20 x 80
P312580	25 x 80
P313280	32 x 80
P314080	40 x 80
P311090	10 x 90
P311390	13 x 90
P311690	16 x 90
P312090	20 x 90
P312590	25 x 90
P313290	32 x 90
P314090	40 x 90
P311000	10 x 100
P311300	13 x 100
P311600	16 x 100
P312000	20 x 100
P312500	25 x 100
P313200	32 x 100
P314000	40 x 100

P32

NAAMS CODE	D x L
P321680	16 x 80
P322080	20 x 80
P322580	25 x 80
P323280	32 x 80
P324080	40 x 80
P321690	16 x 90
P322090	20 x 90
P322590	25 x 90
P323290	32 x 90
P324090	40 x 90
P321600	16 x 100
P322000	20 x 100
P322500	25 x 100
P323200	32 x 100
P324000	40 x 100

RECTANGULAR BALL LOCK PUNCH

(P40 THRU P42 SERIES)

GLOBAL STANDARD COMPONENTS



Stamping

04/25/14

(HEAVY DUTY)

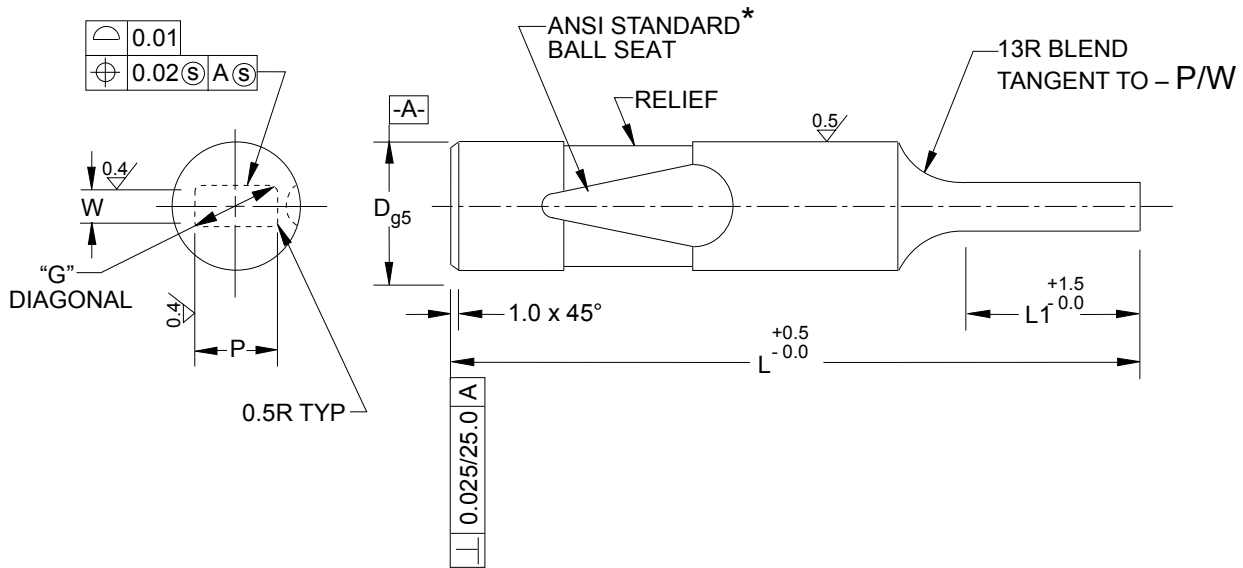

D NOMINAL SHANK Ø	PUNCH POINTS AVAILABLE 0.01 INCREMENTS		L OVERALL LENGTH	L1 POINT LENGTH			PUNCH RETAINER NAAMS CODE
	W MIN	G MAX		STD.	ALT A	ALT B	
10	2.5	9.8	80	19	10	-	P010010
13	5.0	12.8		19	13	25	P010013
16	6.0	15.8		19	13	25	P010016
20	8.0	19.8	90	19	13	25	P010020
25	10.0	24.8		19	13	25	P010025
32	11.5	31.8	100	19	13	25	P010032
40	14.0	39.8		25	19	30	P010040

$$G = 2\sqrt{(P/2-R)^2 + (W/2-R)^2 + R}$$

NOTES & SPECIFICATIONS: $G_{MAX} = D - 0.2$

Material, AISI-M2.

Hardness, Rc 60-63. Triple temper.

Identification, etch the word "Metric" on each piece.

* Ball Seat must conform to ANSI Standard gages for locking location. Functional axis of Ball Seat must be parallel to axis of punch shank within 0.025 per 50 mm on shape punches.

CODING ON FOLLOWING PAGE

A

RECTANGULAR BALL LOCK PUNCH CODING

(P40 THRU P42 SERIES)

Stamping

04/16/96

(HEAVY DUTY)

	Shape & Pnt. Length Style	Shank Dia.	O.A. Length
EX: P40	32	80	

= RECTANGULAR, STD. PNT. x 32 SHANK x 80 LG.

P40 = STD. RECTANGULAR
P41 = ALT. "A" RECTANGULAR
P42 = ALT. "B" RECTANGULAR

P40

NAAMS CODE	D x L
P401080	10 x 80
P401380	13 x 80
P401680	16 x 80
P402080	20 x 80
P402580	25 x 80
P403280	32 x 80
P404080	40 x 80
P401090	10 x 90
P401390	13 x 90
P401690	16 x 90
P402090	20 x 90
P402590	25 x 90
P403290	32 x 90
P404090	40 x 90
P401000	10 x 100
P401300	13 x 100
P401600	16 x 100
P402000	20 x 100
P402500	25 x 100
P403200	32 x 100
P404000	40 x 100

P41

NAAMS CODE	D x L
P411080	10 x 80
P411380	13 x 80
P411680	16 x 80
P412080	20 x 80
P412580	25 x 80
P413280	32 x 80
P414080	40 x 80
P411090	10 x 90
P411390	13 x 90
P411690	16 x 90
P412090	20 x 90
P412590	25 x 90
P413290	32 x 90
P414090	40 x 90
P411000	10 x 100
P411300	13 x 100
P411600	16 x 100
P412000	20 x 100
P412500	25 x 100
P413200	32 x 100
P414000	40 x 100

P42

NAAMS CODE	D x L
P421680	16 x 80
P422080	20 x 80
P422580	25 x 80
P423280	32 x 80
P424080	40 x 80
P421690	16 x 90
P422090	20 x 90
P422590	25 x 90
P423290	32 x 90
P424090	40 x 90
P421600	16 x 100
P422000	20 x 100
P422500	25 x 100
P423200	32 x 100
P424000	40 x 100

ROUND BALL LOCK EJECTOR PUNCH

(P15 THRU P17 SERIES)

GLOBAL STANDARD COMPONENTS



Stamping

04/24/14

(HEAVY DUTY)

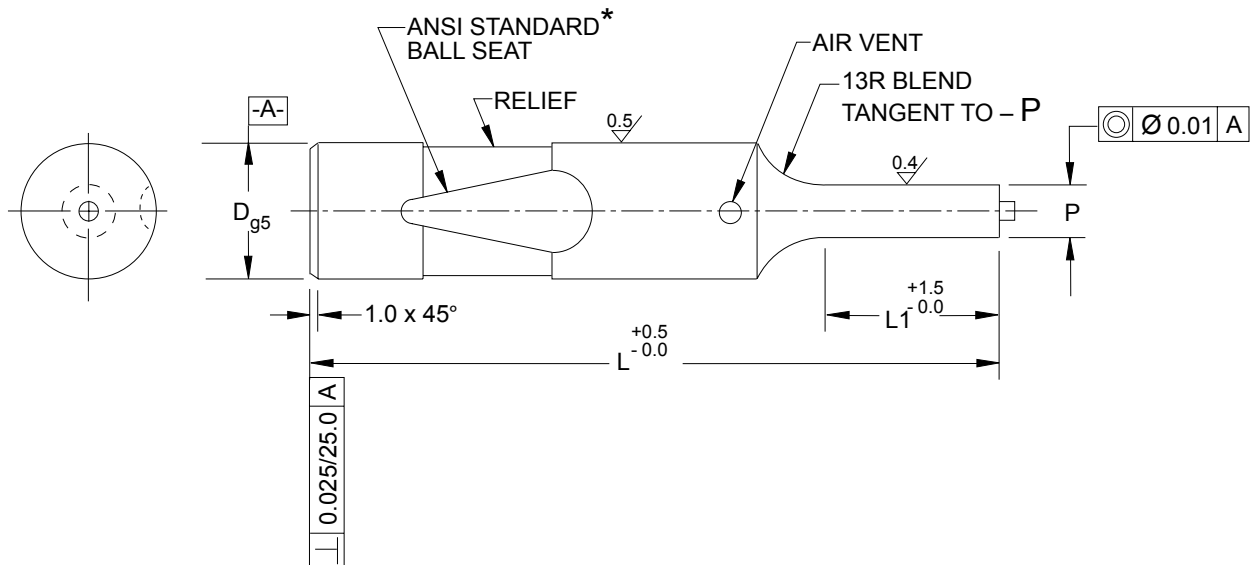

D NOMINAL SHANK Ø	P PUNCH POINTS AVAILABLE 0.01 INCREMENTS	L OVERALL LENGTH	L1 POINT LENGTH			PUNCH RETAINER NAAMS CODE
			STD.	ALT A	ALT B	
10	2.5** to 9.8	80	19	10	–	P010010
13	5.0 to 12.8		19	13	–	P010013
16	8.0 to 15.8		19	13	25	P010016
20	12.0 to 19.8	90	19	13	25	P010020
25	16.0 to 24.8	100	19	13	25	P010025
32	24.0 to 31.8		19	13	25	P010032
40	30.0 to 39.8		19	13	25	P010032
			25	19	30	P010040

NOTES & SPECIFICATIONS:

Material, AISI-M2.

Hardness, Rc 60-63. Triple temper.

Identification, etch the word "Metric" on each piece.

* Ball Seat must conform to ANSI Standard gages for locking location.

** Minimum "P" is 1.5 for alternate point length "A".

CODING ON FOLLOWING PAGE

A

ROUND BALL LOCK EJECTOR PUNCH CODING

(P15 THRU P17 SERIES)

GLOBAL STANDARD COMPONENTS



Stamping

04/16/96

(HEAVY DUTY)

EX:

Shape & Pnt. Length Style	P15
------------------------------	-----

Shank Dia.	32
------------	----

O.A. Length	80
-------------	----

 = ROUND, STD. PNT. x 32 SHANK x 80 LG.

P15 = STD. ROUND
 P16 = ALT. "A" ROUND
 P17 = ALT. "B" ROUND

P15

NAAMS CODE	D x L
P151080	10 x 80
P151380	13 x 80
P151680	16 x 80
P152080	20 x 80
P152580	25 x 80
P153280	32 x 80
P154080	40 x 80
P151090	10 x 90
P151390	13 x 90
P151690	16 x 90
P152090	20 x 90
P152590	25 x 90
P153290	32 x 90
P154090	40 x 90
P151000	10 x 100
P151300	13 x 100
P151600	16 x 100
P152000	20 x 100
P152500	25 x 100
P153200	32 x 100
P154000	40 x 100

P16

NAAMS CODE	D x L
P161080	10 x 80
P161380	13 x 80
P161680	16 x 80
P162080	20 x 80
P162580	25 x 80
P163280	32 x 80
P164080	40 x 80
P161090	10 x 90
P161390	13 x 90
P161690	16 x 90
P162090	20 x 90
P162590	25 x 90
P163290	32 x 90
P164090	40 x 90
P161000	10 x 100
P161300	13 x 100
P161600	16 x 100
P162000	20 x 100
P162500	25 x 100
P163200	32 x 100
P164000	40 x 100

P17

NAAMS CODE	D x L
P171680	16 x 80
P172080	20 x 80
P172580	25 x 80
P173280	32 x 80
P174080	40 x 80
P171690	16 x 90
P172090	20 x 90
P172590	25 x 90
P173290	32 x 90
P174090	40 x 90
P171600	16 x 100
P172000	20 x 100
P172500	25 x 100
P173200	32 x 100
P174000	40 x 100

OBLONG BALL LOCK EJECTOR PUNCH

(P25 THRU P27 SERIES)

GLOBAL STANDARD COMPONENTS



Stamping

04/24/14

(HEAVY DUTY)

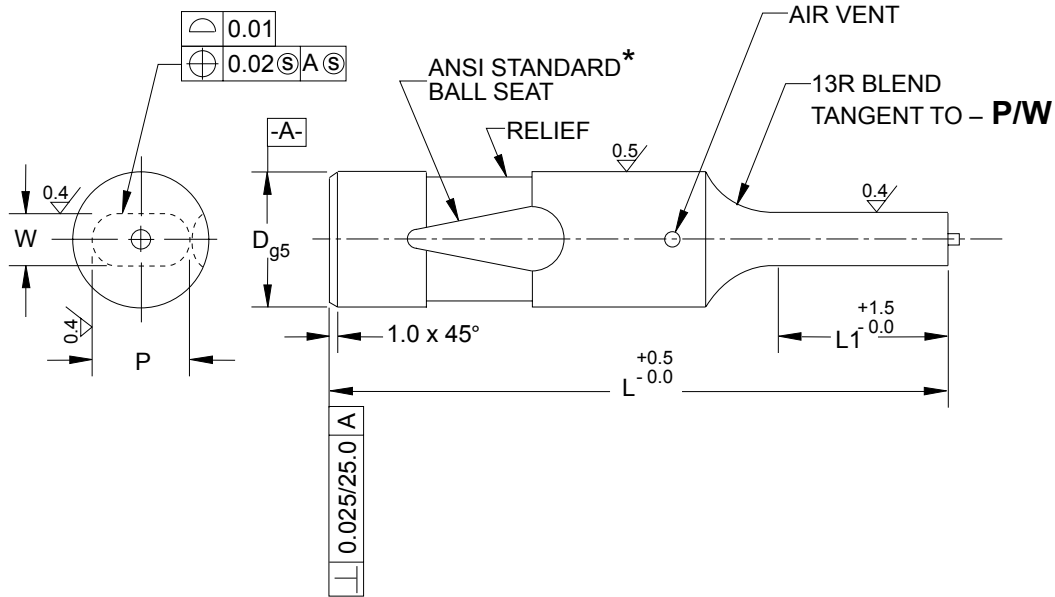

D NOMINAL SHANK Ø	PUNCH POINTS AVAILABLE 0.01 INCREMENTS		L OVERALL LENGTH	L1 POINT LENGTH			PUNCH RETAINER NAAMS CODE
	W MIN	P MAX		STD.	ALT A	ALT B	
10	2.5	9.8	80 90 100	19	10	—	P010010
13	5.0	12.8		19	13	—	P010013
16	6.0	15.8		19	13	25	P010016
20	8.0	19.8		19	13	25	P010020
25	10.0	24.8		19	13	25	P010025
32	11.5	31.8		19	13	25	P010032
40	14.0	39.8		25	19	30	P010040

NOTES & SPECIFICATIONS:

Material, AISI-M2.

Hardness, Rc 60-63. Triple temper.

Identification, etch the word "Metric" on each piece.

- * Ball Seat must conform to ANSI Standard gages for locking location. Functional axis of Ball Seat must be parallel to axis of punch shank within 0.025 per 50 mm on shape punches.

CODING ON FOLLOWING PAGE

A

OBLONG BALL LOCK EJECTOR PUNCH CODING

(P25 THRU P27 SERIES)

Stamping

04/16/96

(HEAVY DUTY)

EX:

Shape & Pnt. Length Style	P25	Shank Dia.	32	O.A. Length	80
------------------------------	-----	------------	----	-------------	----

 = OBLONG, STD. PNT. x 32 SHANK x 80 LG.

P25 = STD. OBLONG
P26 = ALT. "A" OBLONG
P27 = ALT. "B" OBLONG

P25

NAAMS CODE	D x L
P251080	10 x 80
P251380	13 x 80
P251680	16 x 80
P252080	20 x 80
P252580	25 x 80
P253280	32 x 80
P254080	40 x 80
P251090	10 x 90
P251390	13 x 90
P251690	16 x 90
P252090	20 x 90
P252590	25 x 90
P253290	32 x 90
P254090	40 x 90
P251000	10 x 100
P251300	13 x 100
P251600	16 x 100
P252000	20 x 100
P252500	25 x 100
P253200	32 x 100
P254000	40 x 100

P26

NAAMS CODE	D x L
P261080	10 x 80
P261380	13 x 80
P261680	16 x 80
P262080	20 x 80
P262580	25 x 80
P263280	32 x 80
P264080	40 x 80
P261090	10 x 90
P261390	13 x 90
P261690	16 x 90
P262090	20 x 90
P262590	25 x 90
P263290	32 x 90
P264090	40 x 90
P261000	10 x 100
P261300	13 x 100
P261600	16 x 100
P262000	20 x 100
P262500	25 x 100
P263200	32 x 100
P264000	40 x 100

P27

NAAMS CODE	D x L
P271680	16 x 80
P272080	20 x 80
P272580	25 x 80
P273280	32 x 80
P274080	40 x 80
P271690	16 x 90
P272090	20 x 90
P272590	25 x 90
P273290	32 x 90
P274090	40 x 90
P271600	16 x 100
P272000	20 x 100
P272500	25 x 100
P273200	32 x 100
P274000	40 x 100

SQUARE BALL LOCK EJECTOR PUNCH

(P35 THRU P37 SERIES)

GLOBAL STANDARD COMPONENTS



Stamping

04/24/14

(HEAVY DUTY)

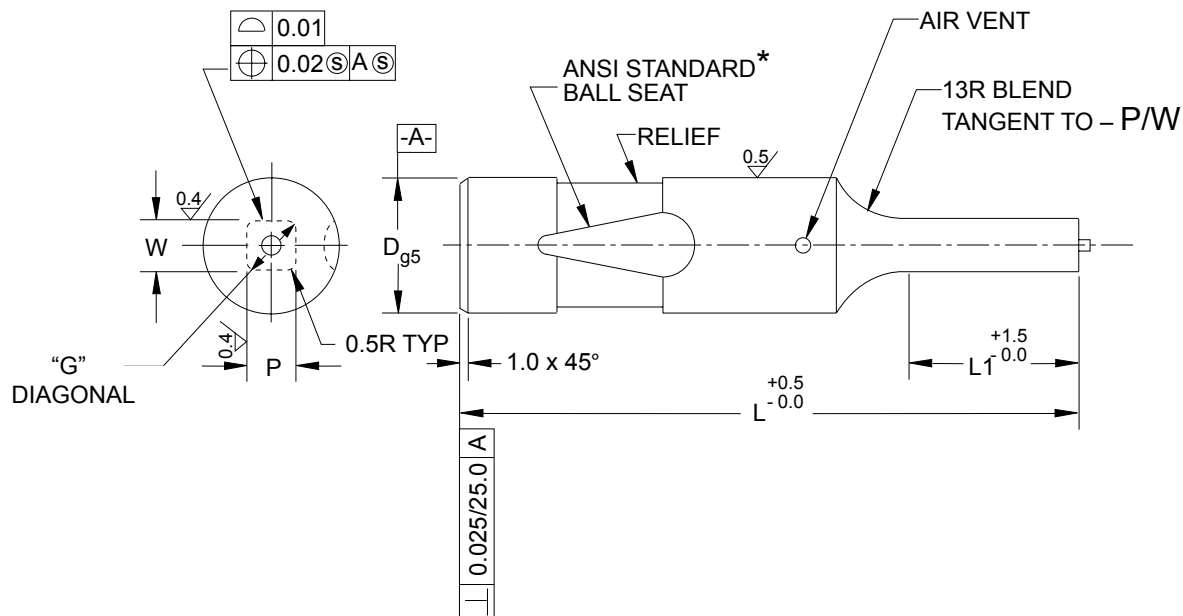

D NOMINAL SHANK Ø	POINTS AVAILABLE IN 0.01 INCREMENTS		L OVERALL LENGTH	L1 POINT LENGTH			PUNCH RETAINER NAAMS CODE	
	W MIN	G MAX		STD.	ALT A	ALT B		
10	2.5	9.8	80	19	10	—	P010010	
13	5.0	12.8		19	13	—	P010013	
16	6.0	15.8		19	13	25	P010016	
20	8.0	19.8		90	19	13	25	P010020
25	10.0	24.8		100	19	13	25	P010025
32	11.5	31.8		19	13	25	P010032	
40	14.0	39.8		25	19	30	P010040	

$$G = 2 \left[\sqrt{(P/2-R)^2 + (W/2-R)^2} + R \right]$$

NOTES & SPECIFICATIONS: $G_{MAX} = D - 0.2$

Material, AISI-M2.

Hardness, Rc 60-63. Triple temper.

Identification, etch the word "Metric" on each piece.

* Ball Seat must conform to ANSI Standard gages for locking location. Functional axis of Ball Seat must be parallel to axis of punch shank within 0.025 per 50 mm on shape punches.

CODING ON FOLLOWING PAGE

A

SQUARE BALL LOCK EJECTOR PUNCH CODING

(P35 THRU P37 SERIES)



Stamping

04/16/96

(HEAVY DUTY)

EX:

Shape & Pnt. Length Style	P35
------------------------------	-----

Shank Dia.	32
------------	----

O.A. Length	80
-------------	----

 = SQUARE, STD. PNT. x 32 SHANK x 80 LG.

P35 = STD. SQUARE
 P36 = ALT. "A" SQUARE
 P37 = ALT. "B" SQUARE

P35

NAAMS CODE	D x L
P351080	10 x 80
P351380	13 x 80
P351680	16 x 80
P352080	20 x 80
P352580	25 x 80
P353280	32 x 80
P354080	40 x 80
P351090	10 x 90
P351390	13 x 90
P351690	16 x 90
P352090	20 x 90
P352590	25 x 90
P353290	32 x 90
P354090	40 x 90
P351000	10 x 100
P351300	13 x 100
P351600	16 x 100
P352000	20 x 100
P352500	25 x 100
P353200	32 x 100
P354000	40 x 100

P36

NAAMS CODE	D x L
P361080	10 x 80
P361380	13 x 80
P361680	16 x 80
P362080	20 x 80
P362580	25 x 80
P363280	32 x 80
P364080	40 x 80
P361090	10 x 90
P361390	13 x 90
P361690	16 x 90
P362090	20 x 90
P362590	25 x 90
P363290	32 x 90
P364090	40 x 90
P361000	10 x 100
P361300	13 x 100
P361600	16 x 100
P362000	20 x 100
P362500	25 x 100
P363200	32 x 100
P364000	40 x 100

P37

NAAMS CODE	D x L
P371680	16 x 80
P372080	20 x 80
P372580	25 x 80
P373280	32 x 80
P374080	40 x 80
P371690	16 x 90
P372090	20 x 90
P372590	25 x 90
P373290	32 x 90
P374090	40 x 90
P371600	16 x 100
P372000	20 x 100
P372500	25 x 100
P373200	32 x 100
P374000	40 x 100

RECTANGULAR BALL LOCK EJECTOR PUNCH

(P45 THRU P47 SERIES)

GLOBAL STANDARD COMPONENTS



Stamping

04/24/14

(HEAVY DUTY)

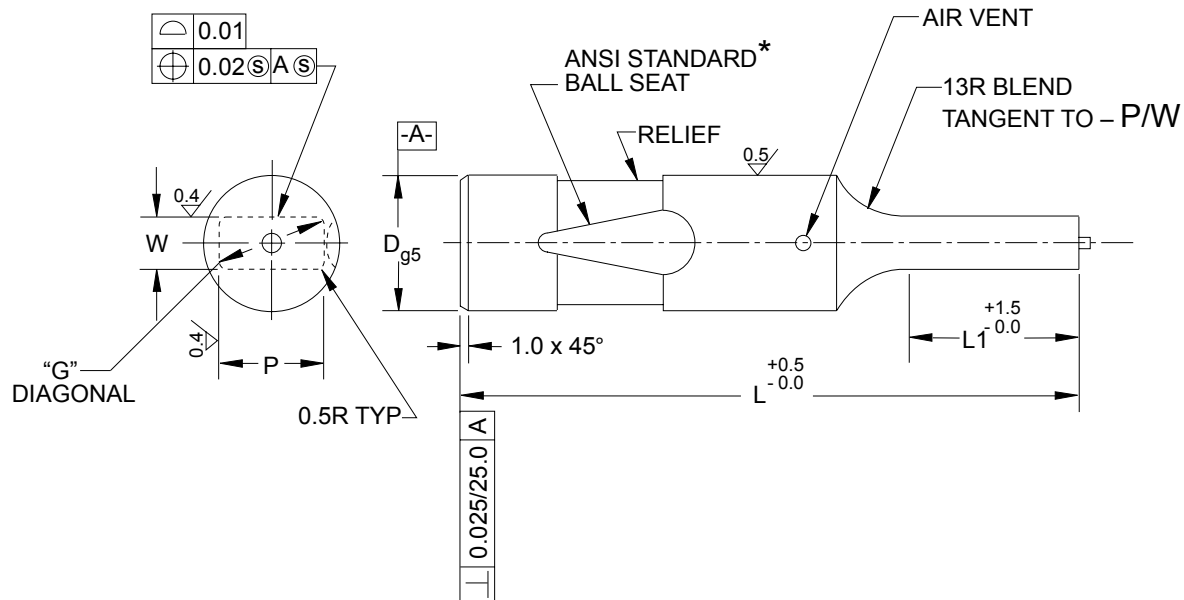

D NOMINAL SHANK Ø	PUNCH POINTS AVAILABLE 0.01 INCREMENTS		L OVERALL LENGTH	L1 POINT LENGTH			PUNCH RETAINER NAAMS CODE
	W MIN	G MAX		STD.	ALT A	ALT B	
10	2.5	9.8	80 90 100	19	10	—	P010010
13	5.0	12.8		19	13	—	P010013
16	6.0	15.8		19	13	25	P010016
20	8.0	19.8		19	13	25	P010020
25	10.0	24.8		19	13	25	P010025
32	11.5	31.8		19	13	25	P010032
40	14.0	39.8		25	19	30	P010040

$$G = 2\left[\sqrt{(P/2-R)^2 + (W/2-R)^2} + R\right]$$

NOTES & SPECIFICATIONS: $G_{MAX} = D - 0.2$

Material, AISI-M2.

Hardness, Rc 60-63. Triple temper.

Identification, etch the word "Metric" on each piece.

*Ball Seat must conform to ANSI Standard gages for locking location. Functional axis of Ball Seat must be parallel to axis of punch shank within 0.025 per 50mm on shape punches.

CODING ON FOLLOWING PAGE

A

RECTANGULAR BALL LOCK EJECTOR PUNCH CODING

(P45 THRU P47 SERIES)



Stamping

04/16/96

(HEAVY DUTY)

Shape & Pnt. Length Style	P45
------------------------------	-----

Shank Dia.	32
------------	----

O.A. Length	80
-------------	----

 = RECTANGULAR, STD. PNT. x 32 SHANK x 80 LG.

P45 = STD. RECTANGULAR
 P46 = ALT. "A" RECTANGULAR
 P47 = ALT. "B" RECTANGULAR

P45

NAAMS CODE	D x L
P451080	10 x 80
P451380	13 x 80
P451680	16 x 80
P452080	20 x 80
P452580	25 x 80
P453280	32 x 80
P454080	40 x 80
P451090	10 x 90
P451390	13 x 90
P451690	16 x 90
P452090	20 x 90
P452590	25 x 90
P453290	32 x 90
P454090	40 x 90
P451000	10 x 100
P451300	13 x 100
P451600	16 x 100
P452000	20 x 100
P452500	25 x 100
P453200	32 x 100
P454000	40 x 100

P46

NAAMS CODE	D x L
P461080	10 x 80
P461380	13 x 80
P461680	16 x 80
P462080	20 x 80
P462580	25 x 80
P463280	32 x 80
P464080	40 x 80
P461090	10 x 90
P461390	13 x 90
P461690	16 x 90
P462090	20 x 90
P462590	25 x 90
P463290	32 x 90
P464090	40 x 90
P461000	10 x 100
P461300	13 x 100
P461600	16 x 100
P462000	20 x 100
P462500	25 x 100
P463200	32 x 100
P464000	40 x 100

P47

NAAMS CODE	D x L
P471680	16 x 80
P472080	20 x 80
P472580	25 x 80
P473280	32 x 80
P474080	40 x 80
P471690	16 x 90
P472090	20 x 90
P472590	25 x 90
P473290	32 x 90
P474090	40 x 90
P471600	16 x 100
P472000	20 x 100
P472500	25 x 100
P473200	32 x 100
P474000	40 x 100

BALL LOCK PILOT PUNCH

(P55 THRU P57 SERIES)

A

(HEAVY DUTY)

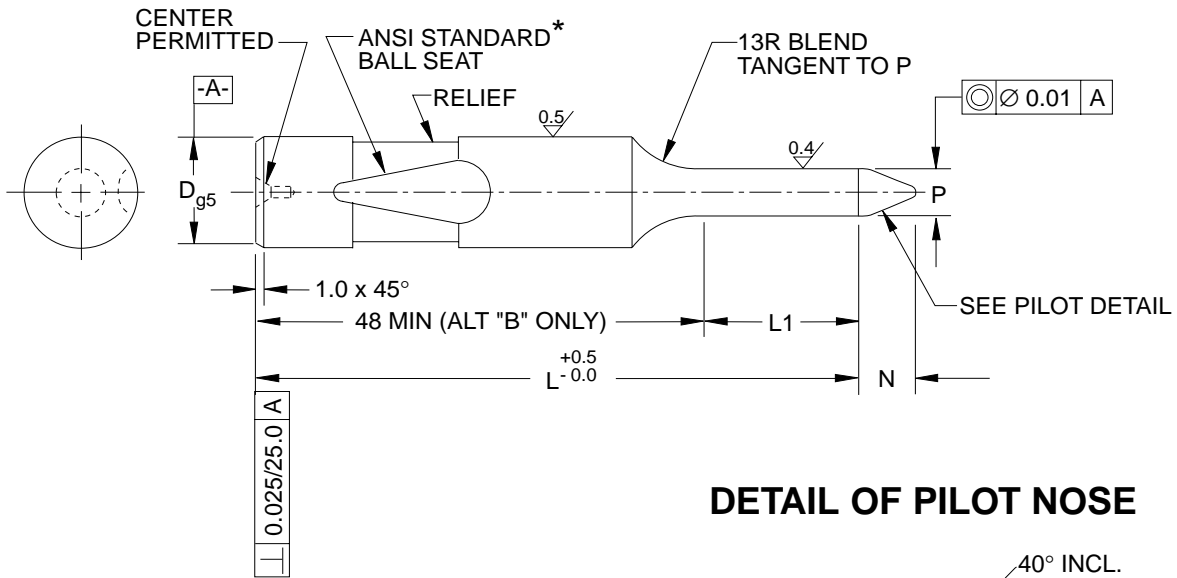

DETAIL OF PILOT NOSE

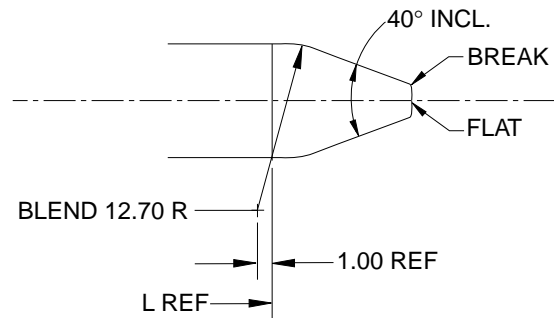

D NOMINAL SHANK Ø	P PUNCH POINT		L OVERALL LENGTH							L1 POINT LENGTH			PUNCH RETAINER NAAMS CODE
	AVAILABLE	N	80	90	100	110	125	140	150	STD.	ALT. A	ALT. B	
10	5.90 – 9.98	8.0	X	X	X	X				19	32	"L" MINUS 48	P010010
13	9.90 – 12.98	10.0	X	X	X	X	X	X		19	32		P010013
16	12.90 – 15.98	15.0	(X)	X	X	X	X	X	X	25	38		P010016
20	15.90 – 19.98	20.0	(X)	X	X	X	X	X	X	25	38		P010020
25	19.90 – 24.98	25.0	(X)	X	X	X	X	X	X	25	38		P010025
32	24.90 – 31.98	30.0	(X)	X	X	X	X	X	X	25	38		P010032
40	31.90 – 39.98	40.0	(X)	(X)	X	X	X	X	X	30	45		P010040

(X) Available in Std & Alt "B"

NOTES & SPECIFICATIONS:

Material, AISI-M2.

Hardness, Rc 60-63. Triple temper.

Identification, etch the word "Metric" on each piece.

*Ball Seat must conform to ANSI Standard gages for locking location.

CODING ON FOLLOWING PAGE

BALL LOCK PILOT PUNCH CODING

(P55 THRU P57 SERIES)



Stamping

07/26/99

A

(HEAVY DUTY)

D x L	NAAMS CODES FOR POINT LENGTH		
	STANDARD	ALTERNATE "A"	ALTERNATE "B"
10 x 80	P551008	P561008	P571008
10 x 90	P551009	P561009	P571009
10 x 100	P551010	P561010	P571010
10 x 110	P551011	P561011	P571011
13 x 80	P551308	P561308	P571308
13 x 90	P551309	P561308	P571309
13 x 100	P551310	P561310	P571310
13 x 110	P551311	P561311	P571311
13 x 125	P551312	P561312	P571312
13 x 140	P551314	P561314	P571314
16 x 80	P551608	---	P571608
16 x 90	P551609	P561609	P571609
16 x 100	P551610	P561610	P571610
16 x 110	P551611	P561611	P571611
16 x 125	P551612	P561612	P571612
16 x 140	P551614	P561614	P571614
16 x 150	P551615	P561615	P571615
20 x 80	P552008	---	P572008
20 x 90	P552009	P562009	P572009
20 x 100	P552010	P562010	P572010
20 x 110	P552011	P562011	P572011
20 x 125	P552012	P562012	P572012
20 x 140	P552014	P562014	P572014
20 x 150	P552015	P562015	P572015
25 x 80	P552508	---	P57208
25 x 90	P552509	P562509	P572509
25 x 100	P552510	P562510	P572510
25 x 110	P552511	P562511	P572511
25 x 125	P552512	P562512	P572512
25 x 140	P552514	P562514	P572514
25 x 150	P552515	P562515	P572515
32 x 80	P553208	---	P573208
32 x 90	P553209	P563209	P573209
32 x 100	P553210	P563210	P573210
32 x 110	P553211	P563211	P573211
32 x 125	P553212	P563212	P573212
32 x 140	P553214	P563214	P573214
32 x 150	P553215	P563215	P573215
40 x 80	P554008	---	P574008
40 x 90	P554009	---	P574009
40 x 100	P554010	P564010	P574010
40 X 110	P554011	P564011	P574011
40 X 125	P554012	P564012	P574012
40 X 140	P554014	P564014	P574014
40 X 150	P554015	P564015	P574015

EXAMPLE

Shape & Pnt. Length Style	Shank Dia.	O.A. Length
P55	25	12

= STD. PNT. PILOT
x 25 mm SHANK
x 125 mm LG.

STRAIGHT RELIEF ROUND DIE BUTTON PRESS FIT, DOWEL SLOT LOCKING DEVICE

(P60 THRU P62 SERIES)

GLOBAL STANDARD COMPONENTS



Stamping

04/24/14

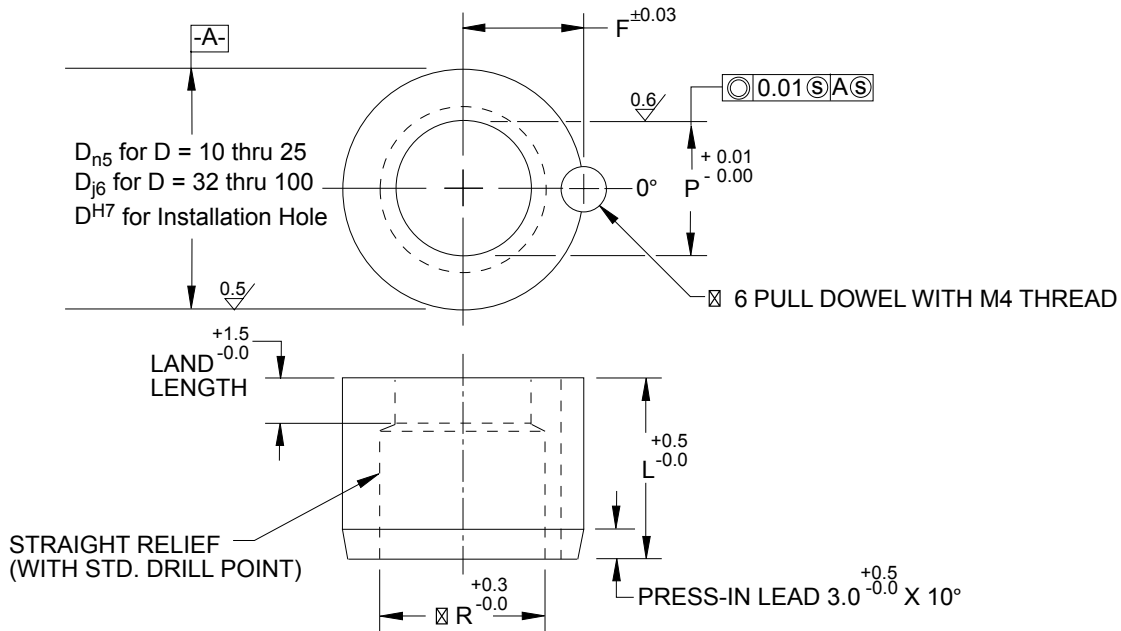

D STANDARD BODY Ø	HOLE SIZE RANGE 0.01 INCREMENTS P Ø	L OVERALL LENGTH					LAND LENGTHS			RELIEF HOLE Ø R MAX	F
		25	28	30	32	35	STD	ALT	ALT		
							S	A	B		
10	1.5 to 5.0	x	x	x	x	x	4	8	-	6.0	7.00
13	1.5 to 7.2	x	x	x	x	x	5	8	-	8.0	8.20
16	5.0 to 8.8	x	x	x	x	x	5	8	-	9.5	9.00
20	5.6 to 11.0	x	x	x	x	x	5	12	20	12.0	11.00
22	9.0 to 14.0	x	x	x	x	x	6	12	20	15.0	12.00
25	10.6 to 16.6	x	x	x	x	x	6	12	20	17.5	13.50
32	13.0 to 20.0	x	x	x	x	x	6	12	20	21.0	16.00
38	16.0 to 26.0	x	x	x	x	x	8	12	20	27.0	19.00
40	16.0 to 26.0	x	x	x	x	x	8	12	20	27.0	20.00
45	19.0 to 35.0	x	x	x	x	x	8	12	20	36.0	22.50
50	22.0 to 40.0	x	x	x	x	x	8	12	20	41.0	25.00
56	25.0 to 45.0	x	x	x	x	x	8	12	20	46.0	28.00
63	28.0 to 50.0	x	x	x	x	x	8	12	20	51.0	31.50
71	31.0 to 56.0	x	x	x	x	x	8	12	20	57.0	35.50
76	39.0 to 60.0	x	x	x	x	x	8	12	20	61.0	38.00
85	43.0 to 66.0	x	x	x	x	x	8	12	20	67.0	42.50
90	45.0 to 70.0	x	x	x	x	x	8	12	20	71.0	45.00
100	50.0 to 78.0	x	x	x	x	x	8	12	20	79.0	50.00

NOTES & SPECIFICATIONS:

- Material, AISI – A2
- Hardness, Rc 60-63
- Identification, etch word "Metric" on each piece

CODING ON FOLLOWING PAGE

A

B

C

D

STRAIGHT RELIEF ROUND DIE BUTTON PRESS FIT, DOWEL SLOT LOCKING DEVICE

(P60 SERIES)

EX:

Shape & Style	Body Dia.	O. A. Length
P60	32	30

 = ROUND x 32 BODY DIA. x 30 LG.

NAAMS CODE	D x L
P601025	10 x 25
P601028	10 x 28
P601030	10 x 30
P601325	13 x 25
P601328	13 x 28
P601330	13 x 30
P601625	16 x 25
P601628	16 x 28
P601630	16 x 30
P601635	16 x 35
P602025	20 x 25
P602028	20 x 28
P602030	20 x 30
P602035	20 x 35
P602225	22 x 25
P602228	22 x 28
P602230	22 x 30
P602235	22 x 35
P602525	25 x 25
P602528	25 x 28
P602530	25 x 30
P602535	25 x 35

NAAMS CODE	D x L
P603225	32 x 25
P603228	32 x 28
P603230	32 x 30
P603235	32 x 35
P603825	38 x 25
P603828	38 x 28
P603830	38 x 30
P603835	38 x 35
P604025	40 x 25
P604028	40 x 28
P604030	40 x 30
P604035	40 x 35
P604525	45 x 25
P604528	45 x 28
P604530	45 x 30
P604535	45 x 35
P605025	50 x 25
P605028	50 x 28
P605030	50 x 30
P605035	50 x 35
P605625	56 x 25
P605628	56 x 28
P605630	56 x 30
P605635	56 x 35

NAAMS CODE	D x L
P606325	63 x 25
P606328	63 x 28
P606330	63 x 30
P606335	63 x 35
P607125	71 x 25
P607128	71 x 28
P607130	71 x 30
P607135	71 x 35
P607625	76 x 25
P607628	76 x 28
P607630	76 x 30
P607635	76 x 35
P608525	85 x 25
P608528	85 x 28
P608530	85 x 30
P608535	85 x 35
P609025	90 x 25
P609028	90 x 28
P609030	90 x 30
P609035	90 x 35
P600025	100 x 25
P600028	100 x 28
P600030	100 x 30
P600035	100 x 35

CODING CONTINUED ON FOLLOWING PAGE

STRAIGHT RELIEF ROUND DIE BUTTON PRESS FIT, DOWEL SLOT LOCKING DEVICE

(P61 SERIES)

EX:

Shape & Style	P61
---------------	-----

Body Dia.	32
-----------	----

O. A. Length	30
--------------	----

 = ROUND ALT "A" x 32 BODY DIA. x 30 LG.

NAAMS CODE	D x L
P611025	10 x 25
P611028	10 x 28
P611030	10 x 30
P611325	13 x 25
P611328	13 x 28
P611330	13 x 30
P611625	16 x 25
P611628	16 x 28
P611630	16 x 30
P611635	16 x 35
P612025	20 x 25
P612028	20 x 28
P612030	20 x 30
P612035	20 x 35
P612225	22 x 25
P612228	22 x 28
P612230	22 x 30
P612235	22 x 35
P612525	25 x 25
P612528	25 x 28
P612530	25 x 30
P612535	25 x 35

NAAMS CODE	D x L
P613225	32 x 25
P613228	32 x 28
P613230	32 x 30
P613235	32 x 35
P613825	38 x 25
P613828	38 x 28
P613830	38 x 30
P613835	38 x 35
P614025	40 x 25
P614028	40 x 28
P614030	40 x 30
P614035	40 x 35
P614525	45 x 25
P614528	45 x 28
P614530	45 x 30
P614535	45 x 35
P615025	50 x 25
P615028	50 x 28
P615030	50 x 30
P615035	50 x 35
P615625	56 x 25
P615628	56 x 28
P615630	56 x 30
P615635	56 x 35

NAAMS CODE	D x L
P616325	63 x 25
P616328	63 x 28
P616330	63 x 30
P616335	63 x 35
P617125	71 x 25
P617128	71 x 28
P617130	71 x 30
P617135	71 x 35
P617625	76 x 25
P617628	76 x 28
P617630	76 x 30
P617635	76 x 35
P618525	85 x 25
P618528	85 x 28
P618530	85 x 30
P618535	85 x 35
P619025	90 x 25
P619028	90 x 28
P619030	90 x 30
P619035	90 x 35
P610025	100 x 25
P610028	100 x 28
P610030	100 x 30
P610035	100 x 35

CODING CONTINUED ON FOLLOWING PAGE

STRAIGHT RELIEF ROUND DIE BUTTON PRESS FIT, DOWEL SLOT LOCKING DEVICE

(P62 SERIES)

EX:

Shape & Style	P62
---------------	-----

Body Dia.	32
-----------	----

O. A. Length	30
--------------	----

 = ROUND ALT "B" x 32 BODY DIA. x 30 LG.

NAAMS CODE	D x L
P622025	20 x 25
P622028	20 x 28
P622030	20 x 30
P622035	20 x 35
P622225	22 x 25
P622228	22 x 28
P622230	22 x 30
P622235	22 x 35
P622525	25 x 25
P622528	25 x 28
P622530	25 x 30
P622535	25 x 35
P623225	32 x 25
P623228	32 x 28
P623230	32 x 30
P623235	32 x 35
P623825	38 x 25
P623828	38 x 28
P623830	38 x 30
P623835	38 x 35

NAAMS CODE	D x L
P624025	40 x 25
P624028	40 x 28
P624030	40 x 30
P624035	40 x 35
P624525	45 x 25
P624528	45 x 28
P624530	45 x 30
P624535	45 x 35
P625025	50 x 25
P625028	50 x 28
P625030	50 x 30
P625035	50 x 35
P625625	56 x 25
P625628	56 x 28
P625630	56 x 30
P625635	56 x 35
P626325	63 x 25
P626328	63 x 28
P626330	63 x 30
P626335	63 x 35

NAAMS CODE	D x L
P627125	71 x 25
P627128	71 x 28
P627130	71 x 30
P627135	71 x 35
P627625	76 x 25
P627628	76 x 28
P627630	76 x 30
P627635	76 x 35
P628525	85 x 25
P628528	85 x 28
P628530	85 x 30
P628535	85 x 35
P629025	90 x 25
P629028	90 x 28
P629030	90 x 30
P629035	90 x 35
P620025	100 x 25
P620028	100 x 28
P620030	100 x 30
P620035	100 x 35

STRAIGHT RELIEF OBLONG DIE BUTTON PRESS FIT, DOWEL SLOT LOCKING DEVICE

(P70 THRU P72 SERIES)

GLOBAL STANDARD COMPONENTS



Stamping

04/24/14

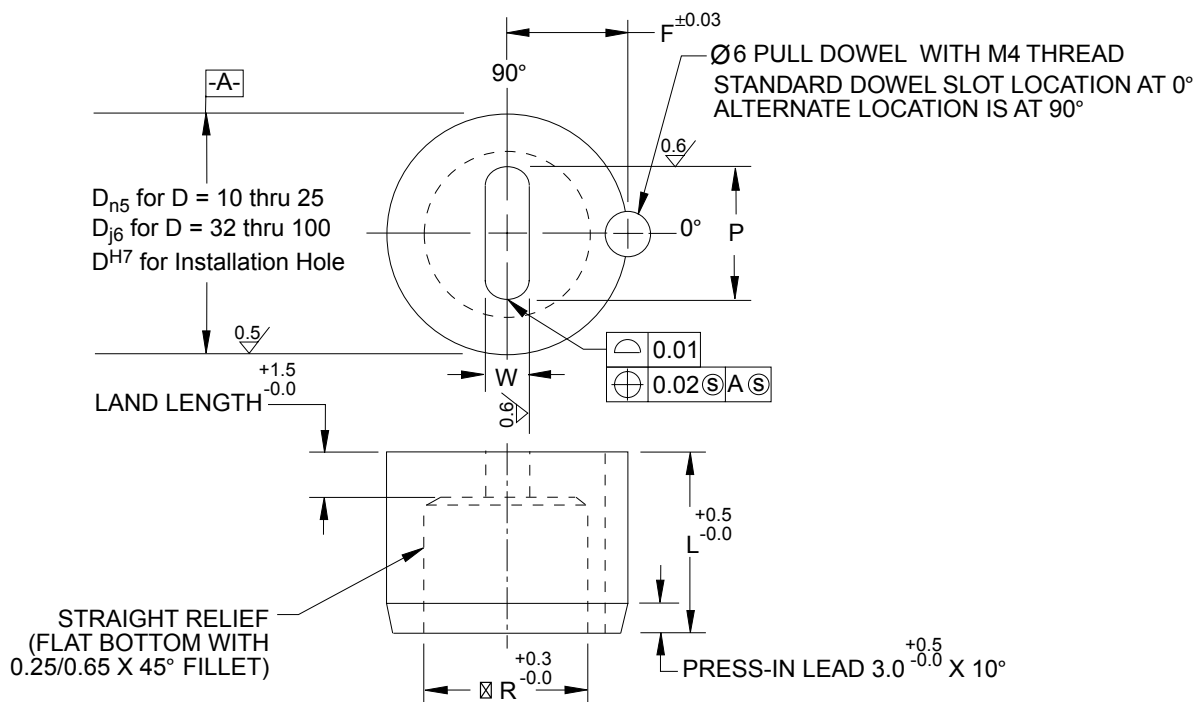

A

D STANDARD BODY Ø	HOLE SIZE RANGE 0.01 INCREMENTS		L OVERALL LENGTH					LAND LENGTHS			RELIEF HOLE Ø R MAX	F
	W MIN	P MAX	25	28	30	32	35	STD.	ALT	ALT		
								S	A	B		
10	1.5	5.0	x	x	x	x	x	4	8	—	6.0	7.00
13	1.5	7.2	x	x	x	x	x	5	8	—	8.0	8.20
16	1.5	8.8	x	x	x	x	x	5	8	—	9.5	9.00
20	3.2	11.0	x	x	x	x	x	5	12	20	12.0	11.00
22	4.0	14.0	x	x	x	x	x	6	12	20	15.0	12.00
25	4.8	16.5	x	x	x	x	x	6	12	20	17.5	13.50
32	5.5	20.0	x	x	x	x	x	6	12	20	21.0	16.00
38	6.4	26.0	x	x	x	x	x	8	12	20	27.0	19.00
40	6.4	26.0	x	x	x	x	x	8	12	20	27.0	20.00
45	8.0	35.0	x	x	x	x	x	8	12	20	36.0	22.50
50	9.0	45.0	x	x	x	x	x	8	12	20	41.0	25.00
56	10.0	45.0	x	x	x	x	x	8	12	20	46.0	28.00
63	11.0	50.0	x	x	x	x	x	8	12	20	51.0	31.50
71	12.0	56.0	x	x	x	x	x	8	12	20	57.0	35.50
76	15.0	60.0	x	x	x	x	x	8	12	20	61.0	38.00
85	21.0	66.0	x	x	x	x	x	8	12	20	67.0	42.50
90	25.0	70.0	x	x	x	x	x	8	12	20	71.0	45.00
100	33.0	70.0	x	x	x	x	x	8	12	20	79.0	50.00

B
C

NOTES & SPECIFICATIONS:

Material, AISI – A2

Hardness, Rc 60-63

Identification, etch word "Metric" on each piece

CODING ON FOLLOWING PAGE

STRAIGHT RELIEF OBLONG DIE BUTTON PRESS FIT, DOWEL SLOT LOCKING DEVICE

(P70 SERIES)

Shape & Style: **P70** Body Dia.: **32** O.A. Length: **30** = OBLONG STD. x 32 BODY DIA. x 30 LG.

NAAMS CODE	D x L
P701025	10 x 25
P701028	10 x 28
P701030	10 x 30
P701325	13 x 25
P701328	13 x 28
P701330	13 x 30
P701625	16 x 25
P701628	16 x 28
P701630	16 x 30
P701635	16 x 35
P702025	20 x 25
P702028	20 x 28
P702030	20 x 30
P702035	20 x 35
P702225	22 x 25
P702228	22 x 28
P702230	22 x 30
P702235	22 x 35
P702525	25 x 25
P702528	25 x 28
P702530	25 x 30
P702535	25 x 35

NAAMS CODE	D x L
P703225	32 x 25
P703228	32 x 28
P703230	32 x 30
P703235	32 x 35
P703825	38 x 25
P703828	38 x 28
P703830	38 x 30
P703835	38 x 35
P704025	40 x 25
P704028	40 x 28
P704030	40 x 30
P704035	40 x 35
P704525	45 x 25
P704528	45 x 28
P704530	45 x 30
P704535	45 x 35
P705025	50 x 25
P705028	50 x 28
P705030	50 x 30
P705035	50 x 35
P705625	56 x 25
P705628	56 x 28
P705630	56 x 30
P705635	56 x 35

NAAMS CODE	D x L
P706325	63 x 25
P706328	63 x 28
P706330	63 x 30
P706335	63 x 35
P707125	71 x 25
P707128	71 x 28
P707130	71 x 30
P707135	71 x 35
P707625	76 x 25
P707628	76 x 28
P707630	76 x 30
P707635	76 x 35
P708525	85 x 25
P708528	85 x 28
P708530	85 x 30
P708535	85 x 35
P709025	90 x 25
P709028	90 x 28
P709030	90 x 30
P709035	90 x 35
P700025	100 x 25
P700028	100 x 28
P700030	100 x 30
P700035	100 x 35

CODING CONTINUED ON FOLLOWING PAGE

STRAIGHT RELIEF OBLONG DIE BUTTON PRESS FIT, DOWEL SLOT LOCKING DEVICE

(P71 SERIES)

EX:

Shape & Style	P71
------------------	-----

Body Dia.	32
-----------	----

O.A. Length	30
-------------	----

 = OBLONG ALT "A" x 32 BODY DIA. x 30 LG.

NAAMS CODE	D x L
P711025	10 x 25
P711028	10 x 28
P711030	10 x 30
P711325	13 x 25
P711328	13 x 28
P711330	13 x 30
P711625	16 x 25
P711628	16 x 28
P711630	16 x 30
P711635	16 x 35
P712025	20 x 25
P712028	20 x 28
P712030	20 x 30
P712035	20 x 35
P712225	22 x 25
P712228	22 x 28
P712230	22 x 30
P712235	22 x 35
P712525	25 x 25
P712528	25 x 28
P712530	25 x 30
P712535	25 x 35

NAAMS CODE	D x L
P713225	32 x 25
P713228	32 x 28
P713230	32 x 30
P713235	32 x 35
P713825	38 x 25
P713828	38 x 28
P713830	38 x 30
P713835	38 x 35
P714025	40 x 25
P714028	40 x 28
P714030	40 x 30
P714035	40 x 35
P714525	45 x 25
P714528	45 x 28
P714530	45 x 30
P714535	45 x 35
P715025	50 x 25
P715028	50 x 28
P715030	50 x 30
P715035	50 x 35
P715625	56 x 25
P715628	56 x 28
P715630	56 x 30
P715635	56 x 35

NAAMS CODE	D x L
P716325	63 x 25
P716328	63 x 28
P716330	63 x 30
P716335	63 x 35
P717125	71 x 25
P717128	71 x 28
P717130	71 x 30
P717135	71 x 35
P717625	76 x 25
P717628	76 x 28
P717630	76 x 30
P717635	76 x 35
P718525	85 x 25
P718528	85 x 28
P718530	85 x 30
P718535	85 x 35
P719025	90 x 25
P719028	90 x 28
P719030	90 x 30
P719035	90 x 35
P710025	100 x 25
P710028	100 x 28
P710030	100 x 30
P710035	100 x 35

CODING CONTINUED ON FOLLOWING PAGE

STRAIGHT RELIEF OBLONG DIE BUTTON PRESS FIT, DOWEL SLOT LOCKING DEVICE

(P72 SERIES)

EX:

Shape & Style
P72

Body Dia.
32

O.A. Length
30

 = OBLONG ALT "B" x 32 BODY DIA. x 30 LG.

NAAMS CODE	D x L
P722025	20 x 25
P722028	20 x 28
P722030	20 x 30
P722035	20 x 35
P722225	22 x 25
P722228	22 x 28
P722230	22 x 30
P722235	22 x 35
P722525	25 x 25
P722528	25 x 28
P722530	25 x 30
P722535	25 x 35
P723225	32 x 25
P723228	32 x 28
P723230	32 x 30
P723235	32 x 35
P723825	38 x 25
P723828	38 x 28
P723830	38 x 30
P723835	38 x 35

NAAMS CODE	D x L
P724025	40 x 25
P724028	40 x 28
P724030	40 x 30
P724035	40 x 35
P724525	45 x 25
P724528	45 x 28
P724530	45 x 30
P724535	45 x 35
P725025	50 x 25
P725028	50 x 28
P725030	50 x 30
P725035	50 x 35
P725625	56 x 25
P725628	56 x 28
P725630	56 x 30
P725635	56 x 35
P726325	63 x 25
P726328	63 x 28
P726330	63 x 30
P726335	63 x 35

NAAMS CODE	D x L
P727125	71 x 25
P727128	71 x 28
P727130	71 x 30
P727135	71 x 35
P727625	76 x 25
P727628	76 x 28
P727630	76 x 30
P727635	76 x 35
P728525	85 x 25
P728528	85 x 28
P728530	85 x 30
P728535	85 x 35
P729025	90 x 25
P729028	90 x 28
P729030	90 x 30
P729035	90 x 35
P720025	100 x 25
P720028	100 x 28
P720030	100 x 30
P720035	100 x 35

STRAIGHT RELIEF SQUARE DIE BUTTON PRESS FIT, DOWEL SLOT LOCKING DEVICE

(P80 THRU P82 SERIES)

GLOBAL STANDARD COMPONENTS



Stamping

04/24/14

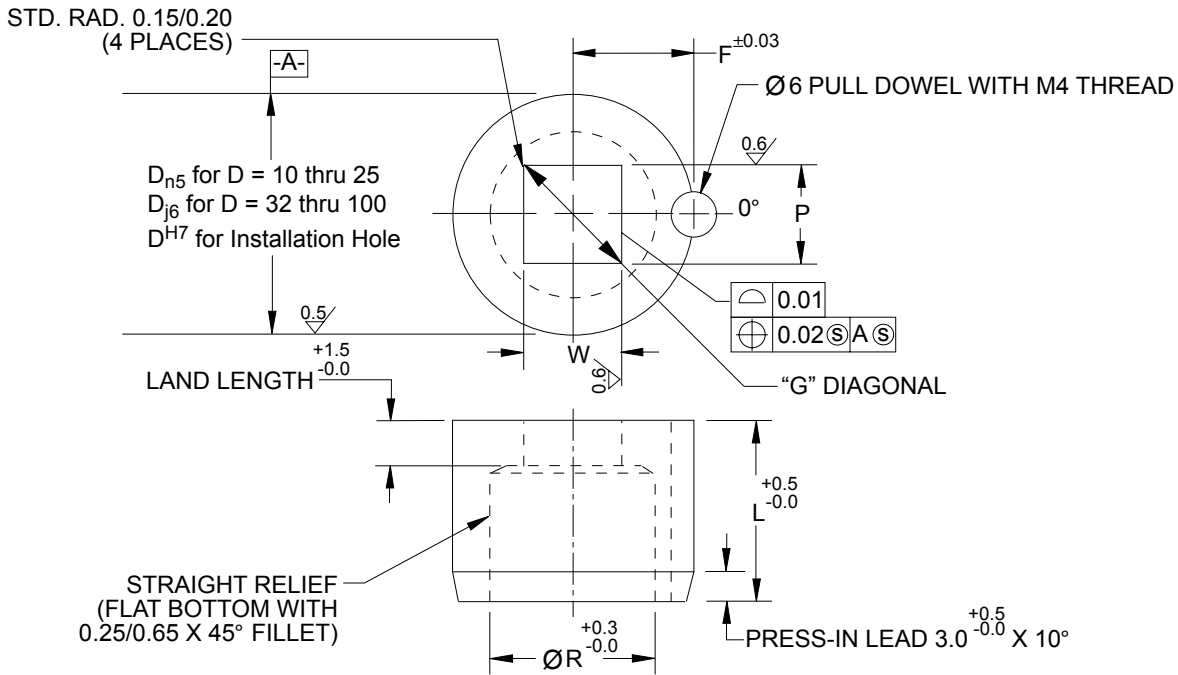

D STANDARD BODY	HOLE SIZE RANGE 0.01 INCREMENTS		L OVERALL LENGTH					LAND LENGTHS			RELIEF HOLE Ø R MAX	F
	W MIN	G MAX	25	28	30	32	35	STD S	ALT A	ALT B		
10	1.5 to	5.0	x	x	x	x	x	4	8	-	6.0	7.00
13	1.5 to	7.2	x	x	x	x	x	5	8	-	8.0	8.20
16	2.5 to	8.8	x	x	x	x	x	5	8	-	9.5	9.00
20	3.2 to	11.0	x	x	x	x	x	5	12	20	12.0	11.00
22	4.0 to	14.0	x	x	x	x	x	6	12	20	15.0	12.00
25	4.0 to	16.5	x	x	x	x	x	6	12	20	17.5	13.50
32	5.5 to	20.0	x	x	x	x	x	6	12	20	21.0	16.00
38	6.4 to	26.0	x	x	x	x	x	8	12	20	27.0	19.00
40	6.4 to	26.0	x	x	x	x	x	8	12	20	27.0	20.00
45	8.0 to	35.0	x	x	x	x	x	8	12	20	36.0	22.50
50	9.0 to	45.0	x	x	x	x	x	8	12	20	41.0	25.00
56	10.0 to	45.0	x	x	x	x	x	8	12	20	46.0	28.00
63	11.0 to	50.0	x	x	x	x	x	8	12	20	51.0	31.50
71	12.0 to	56.0	x	x	x	x	x	8	12	20	57.0	35.50
76	15.0 to	60.0	x	x	x	x	x	8	12	20	61.0	38.00
85	21.0 to	66.0	x	x	x	x	x	8	12	20	67.0	42.50
90	25.0 to	70.0	x	x	x	x	x	8	12	20	71.0	45.00
100	33.0 to	70.0	x	x	x	x	x	8	12	20	79.0	50.00

$$G = 2\sqrt{(P/2-R)^2 + (W/2-R)^2} + R$$

NOTES & SPECIFICATIONS: $G_{MAX} = D - 0.2$

Material, AISI – A2

Hardness, Rc 60-63

Identification, etch word "Metric" on each piece

CODING ON FOLLOWING PAGE

A

B

C

STRAIGHT RELIEF SQUARE DIE BUTTON PRESS FIT, DOWEL SLOT LOCKING DEVICE

(P80 SERIES)

EX:

Shape & Style	P80
------------------	-----

Body Dia.	32
-----------	----

O.A. Length	30
-------------	----

 = SQUARE STD. x 32 BODY DIA. x 30 LG.

NAAMS CODE	D x L
P801025	10 x 25
P801028	10 x 28
P801030	10 x 30
P801325	13 x 25
P801328	13 x 28
P801330	13 x 30
P801625	16 x 25
P801628	16 x 28
P801630	16 x 30
P801635	16 x 35
P802025	20 x 25
P802028	20 x 28
P802030	20 x 30
P802035	20 x 35
P802225	22 x 25
P802228	22 x 28
P802230	22 x 30
P802235	22 x 35
P802525	25 x 25
P802528	25 x 28
P802530	25 x 30
P802535	25 x 35

NAAMS CODE	D x L
P803225	32 x 25
P803228	32 x 28
P803230	32 x 30
P803235	32 x 35
P803825	38 x 25
P803828	38 x 28
P803830	38 x 30
P803835	38 x 35
P804025	40 x 25
P804028	40 x 28
P804030	40 x 30
P804035	40 x 35
P804525	45 x 25
P804528	45 x 28
P804530	45 x 30
P804535	45 x 35
P805025	50 x 25
P805028	50 x 28
P805030	50 x 30
P805035	50 x 35
P805625	56 x 25
P805628	56 x 28
P805630	56 x 30
P805635	56 x 35

NAAMS CODE	D x L
P806325	63 x 25
P806328	63 x 28
P806330	63 x 30
P806335	63 x 35
P807125	71 x 25
P807128	71 x 28
P807130	71 x 30
P807135	71 x 35
P807625	76 x 25
P807628	76 x 28
P807630	76 x 30
P807635	76 x 35
P808525	85 x 25
P808528	85 x 28
P808530	85 x 30
P808535	85 x 35
P809025	90 x 25
P809028	90 x 28
P809030	90 x 30
P809035	90 x 35
P800025	100 x 25
P800028	100 x 28
P800030	100 x 30
P800035	100 x 35

CODING CONTINUED ON FOLLOWING PAGE

STRAIGHT RELIEF SQUARE DIE BUTTON PRESS FIT, DOWEL SLOT LOCKING DEVICE

(P81 SERIES)

EX:

Shape & Style	P81
------------------	-----

Body Dia.	32
-----------	----

O.A. Length	30
-------------	----

 = SQUARE ALT "A" x 32 BODY DIA. x 30 LG.

NAAMS CODE	D x L
P811025	10 x 25
P811028	10 x 28
P811030	10 x 30
P811325	13 x 25
P811328	13 x 28
P811330	13 x 30
P811625	16 x 25
P811628	16 x 28
P811630	16 x 30
P811635	16 x 35
P812025	20 x 25
P812028	20 x 28
P812030	20 x 30
P812035	20 x 35
P812225	22 x 25
P812228	22 x 28
P812230	22 x 30
P812235	22 x 35
P812525	25 x 25
P812528	25 x 28
P812530	25 x 30
P812535	25 x 35

NAAMS CODE	D x L
P813225	32 x 25
P813228	32 x 28
P813230	32 x 30
P813235	32 x 35
P813825	38 x 25
P813828	38 x 28
P813830	38 x 30
P813835	38 x 35
P814025	40 x 25
P814028	40 x 28
P814030	40 x 30
P814035	40 x 35
P814525	45 x 25
P814528	45 x 28
P814530	45 x 30
P814535	45 x 35
P815025	50 x 25
P815028	50 x 28
P815030	50 x 30
P815035	50 x 35
P815625	56 x 25
P815628	56 x 28
P815630	56 x 30
P815635	56 x 35

NAAMS CODE	D x L
P816325	63 x 25
P816328	63 x 28
P816330	63 x 30
P816335	63 x 35
P817125	71 x 25
P817128	71 x 28
P817130	71 x 30
P817135	71 x 35
P817625	76 x 25
P817628	76 x 28
P817630	76 x 30
P817635	76 x 35
P818525	85 x 25
P818528	85 x 28
P818530	85 x 30
P818535	85 x 35
P819025	90 x 25
P819028	90 x 28
P819030	90 x 30
P819035	90 x 35
P810025	100 x 25
P810028	100 x 28
P810030	100 x 30
P810035	100 x 35

CODING CONTINUED ON THE FOLLOWING PAGE

STRAIGHT RELIEF SQUARE DIE BUTTON PRESS FIT, DOWEL SLOT LOCKING DEVICE

(P82 SERIES)



Stamping

04/16/96

EX:

Shape & Style	P82
------------------	-----

Body Dia.	32
-----------	----

O.A. Length	30
-------------	----

 = SQUARE ALT "B" x 32 BODY DIA. x 30 LG.

NAAMS CODE	D x L
P822025	20 x 25
P822028	20 x 28
P822030	20 x 30
P822035	20 x 35
P822225	22 x 25
P822228	22 x 28
P822230	22 x 30
P822235	22 x 35
P822525	25 x 25
P822528	25 x 28
P822530	25 x 30
P822535	25 x 35
P823225	32 x 25
P823228	32 x 28
P823230	32 x 30
P823235	32 x 35
P823825	38 x 25
P823828	38 x 28
P823830	38 x 30
P823835	38 x 35

NAAMS CODE	D x L
P824025	40 x 25
P824028	40 x 28
P824030	40 x 30
P824035	40 x 35
P824525	45 x 25
P824528	45 x 28
P824530	45 x 30
P824535	45 x 35
P825025	50 x 25
P825028	50 x 28
P825030	50 x 30
P825035	50 x 35
P825625	56 x 25
P825628	56 x 28
P825630	56 x 30
P825635	56 x 35
P826325	63 x 25
P826328	63 x 28
P826330	63 x 30
P826335	63 x 35

NAAMS CODE	D x L
P827125	71 x 25
P827128	71 x 28
P827130	71 x 30
P827135	71 x 35
P827625	76 x 25
P827628	76 x 28
P827630	76 x 30
P827635	76 x 35
P828525	85 x 25
P828528	85 x 28
P828530	85 x 30
P828535	85 x 35
P829025	90 x 25
P829028	90 x 28
P829030	90 x 30
P829035	90 x 35
P820025	100 x 25
P820028	100 x 28
P820030	100 x 30
P820035	100 x 35

STRAIGHT RELIEF RECTANGULAR DIE BUTTON PRESS FIT, DOWEL SLOT LOCKING DEVICE

(P90 SERIES)

GLOBAL STANDARD COMPONENTS



Stamping

04/16/96

Shape & Style	P90
---------------	-----

Body Dia.	32
-----------	----

O.A. Length	30
-------------	----

 = RECTANGULAR x 32 BODY DIA. x 30 LG.

NAAMS CODE	D x L
P901025	10 x 25
P901028	10 x 28
P901030	10 x 30
P901325	13 x 25
P901328	13 x 28
P901330	13 x 30
P901625	16 x 25
P901628	16 x 28
P901630	16 x 30
P901635	16 x 35
P902025	20 x 25
P902028	20 x 28
P902030	20 x 30
P902035	20 x 35
P902225	22 x 25
P902228	22 x 28
P902230	22 x 30
P902235	22 x 35
P902525	25 x 25
P902528	25 x 28
P902530	25 x 30
P902535	25 x 35

NAAMS CODE	D x L
P903225	32 x 25
P903228	32 x 28
P903230	32 x 30
P903235	32 x 35
P903825	38 x 25
P903828	38 x 28
P903830	38 x 30
P903835	38 x 35
P904025	40 x 25
P904028	40 x 28
P904030	40 x 30
P904035	40 x 35
P904525	45 x 25
P904528	45 x 28
P904530	45 x 30
P904535	45 x 35
P905025	50 x 25
P905028	50 x 28
P905030	50 x 30
P905035	50 x 35
P905625	56 x 25
P905628	56 x 28
P905630	56 x 30
P905635	56 x 35

NAAMS CODE	D x L
P906325	63 x 25
P906328	63 x 28
P906330	63 x 30
P906335	63 x 35
P907125	71 x 25
P907128	71 x 28
P907130	71 x 30
P907135	71 x 35
P907625	76 x 25
P907628	76 x 28
P907630	76 x 30
P907635	76 x 35
P908525	85 x 25
P908528	85 x 28
P908530	85 x 30
P908535	85 x 35
P909025	90 x 25
P909028	90 x 28
P909030	90 x 30
P909035	90 x 35
P900025	100 x 25
P900028	100 x 28
P900030	100 x 30
P900035	100 x 35

CODING CONTINUED ON FOLLOWING PAGE

STRAIGHT RELIEF RECTANGULAR DIE BUTTON PRESS FIT, DOWEL SLOT LOCKING DEVICE

(P91 SERIES)

GLOBAL STANDARD COMPONENTS



Stamping

04/16/96

EX:

Shape & Style	Body Dia.	O.A. Length
P91	32	30

 = RECTANGULAR ALT "A" x 32 BODY DIA. x 30 LG.

NAAMS CODE	D x L
P911025	10 x 25
P911028	10 x 28
P911030	10 x 30
P911325	13 x 25
P911328	13 x 28
P911330	13 x 30
P911625	16 x 25
P911628	16 x 28
P911630	16 x 30
P911635	16 x 35
P912025	20 x 25
P912028	20 x 28
P912030	20 x 30
P912035	20 x 35
P912225	22 x 25
P912228	22 x 28
P912230	22 x 30
P912235	22 x 35
P912525	25 x 25
P912528	25 x 28
P912530	25 x 30
P912535	25 x 35

NAAMS CODE	D x L
P913225	32 x 25
P913228	32 x 28
P913230	32 x 30
P913235	32 x 35
P913825	38 x 25
P913828	38 x 28
P913830	38 x 30
P913835	38 x 35
P914025	40 x 25
P914028	40 x 28
P914030	40 x 30
P914035	40 x 35
P914525	45 x 25
P914528	45 x 28
P914530	45 x 30
P914535	45 x 35
P915025	50 x 25
P915028	50 x 28
P915030	50 x 30
P915035	50 x 35
P915625	56 x 25
P915628	56 x 28
P915630	56 x 30
P915635	56 x 35

NAAMS CODE	D x L
P916325	63 x 25
P916328	63 x 28
P916330	63 x 30
P916335	63 x 35
P917125	71 x 25
P917128	71 x 28
P917130	71 x 30
P917135	71 x 35
P917625	76 x 25
P917628	76 x 28
P917630	76 x 30
P917635	76 x 35
P918525	85 x 25
P918528	85 x 28
P918530	85 x 30
P918535	85 x 35
P919025	90 x 25
P919028	90 x 28
P919030	90 x 30
P919035	90 x 35
P910025	100 x 25
P910028	100 x 28
P910030	100 x 30
P910035	100 x 35

CODING CONTINUED ON FOLLOWING PAGE

STRAIGHT RELIEF RECTANGULAR DIE BUTTON PRESS FIT, DOWEL SLOT LOCKING DEVICE

(P92 SERIES)

GLOBAL STANDARD COMPONENTS



Stamping

04/16/96

EX:

Shape & Style	P92
---------------	-----

Body Dia.	32
-----------	----

O.A. Length	30
-------------	----

 = RECTANGULAR ALT "B" x 32 BODY DIA. x 30 LG.

NAAMS CODE	D x L
P922025	20 x 25
P922028	20 x 28
P922030	20 x 30
P922035	20 x 35
P922225	22 x 25
P922228	22 x 28
P922230	22 x 30
P922235	22 x 35
P922525	25 x 25
P922528	25 x 28
P922530	25 x 30
P922535	25 x 35
P923225	32 x 25
P923228	32 x 28
P923230	32 x 30
P923235	32 x 35
P923825	38 x 25
P923828	38 x 28
P923830	38 x 30
P923835	38 x 35

NAAMS CODE	D x L
P924025	40 x 25
P924028	40 x 28
P924030	40 x 30
P924035	40 x 35
P924525	45 x 25
P924528	45 x 28
P924530	45 x 30
P924535	45 x 35
P925025	50 x 25
P925028	50 x 28
P925030	50 x 30
P925035	50 x 35
P925625	56 x 25
P925628	56 x 28
P925630	56 x 30
P925635	56 x 35
P926325	63 x 25
P926328	63 x 28
P926330	63 x 30
P926335	63 x 35

NAAMS CODE	D x L
P927125	71 x 25
P927128	71 x 28
P927130	71 x 30
P927135	71 x 35
P927625	76 x 25
P927628	76 x 28
P927630	76 x 30
P927635	76 x 35
P928525	85 x 25
P928528	85 x 28
P928530	85 x 30
P928535	85 x 35
P929025	90 x 25
P929028	90 x 28
P929030	90 x 30
P929035	90 x 35
P920025	100 x 25
P920028	100 x 28
P920030	100 x 30
P920035	100 x 35

TAPERED RELIEF ROUND DIE BUTTON

(P64 THRU P67 SERIES)

Stamping

07/01/99

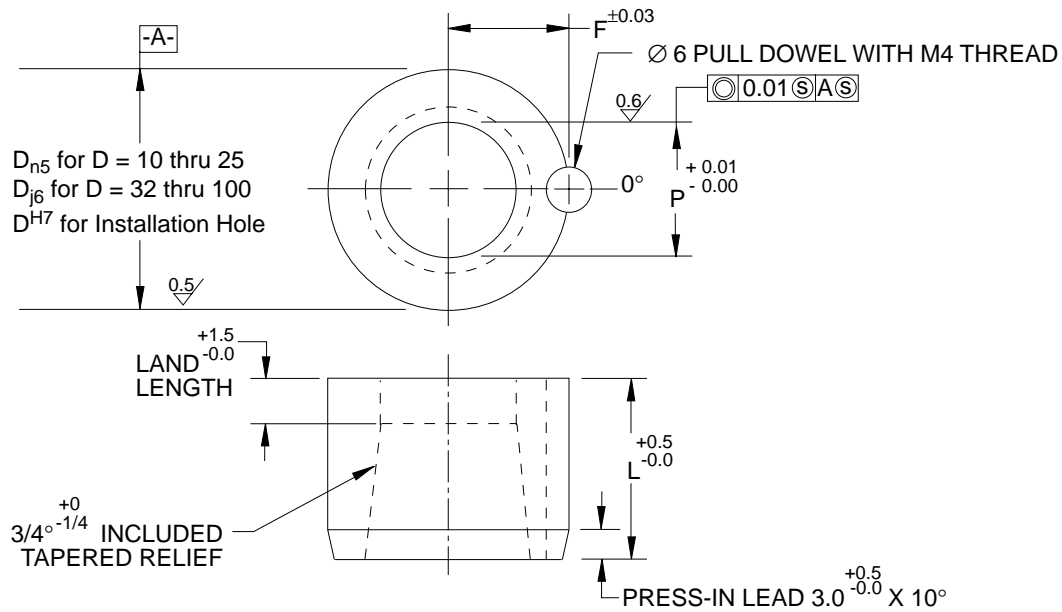

A

D STANDARD BODY Ø	HOLE SIZE RANGE 0.01 INCREMENTS		L OVERALL LENGTH				LAND LENGTHS			F
							STD	ALT	ALT	
	MIN P	MAX P	25	28	30	35	S	A	B	
10	1.60	3.19	x	x			4	-	3	7.00
10	3.20	6.80	x	x	x	x	5	-	3	7.00
13	3.20	8.80	x	x	x	x	5	-	3	8.20
13	5.40	8.80	x	x	x	x	-	8	-	8.20
16	7.40	10.80	x	x	x	x	5	8	3	9.00
20	9.50	13.60	x	x	x	x	5	10	3	11.00
22	10.50	15.00	x	x	x	x	6	10	3	12.00
25	12.00	17.00	x	x	x	x	6	10	3	13.50
32	16.00	22.00	x	x	x	x	6	12	3	16.00
38	18.00	27.00	x	x	x	x	8	12	3	19.00
40	18.00	27.00	x	x	x	x	8	12	3	20.00
45	22.00	31.00	x	x	x	x	8	12	3	22.50
50	24.00	34.00	x	x	x	x	8	12	3	25.00
56	26.00	38.00	x	x	x	x	8	12	3	28.00
63	30.00	43.00	x	x	x	x	8	12	3	31.50
71	34.00	48.00	x	x	x	x	8	12	3	35.50
76	36.00	52.00	x	x	x	x	8	12	3	38.00
85	40.00	58.00	x	x	x	x	8	12	3	42.50
90	43.00	61.00	x	x	x	x	8	12	3	45.00
100	48.00	68.00	x	x	x	x	8	12	3	50.00

NOTES & SPECIFICATIONS:

Material, AISI – A2

Hardness, Rc 60-63

Identification, etch word "Metric" on each piece

CODING ON FOLLOWING PAGE

TAPERED RELIEF ROUND DIE BUTTON CODING

(P64 & P65 SERIES)

GLOBAL STANDARD COMPONENTS



Stamping

04/16/96

(P64 SERIES 4 mm LAND) (P65 SERIES STD. LAND)

EX:

Shape & Style	Body Dia.	O.A. Length
P64	10	25
P65	32	30

= SOLID ROUND 4 mm STD. x 10 BODY DIA. x 25 LG.

= STD. LAND x 32 BODY DIA. x 30 LONG

NAAMS CODE	D x L
P641025	10 x 25
P641028	10 x 28
P651025	10 x 25
P651028	10 x 28
P651030	10 x 30
P651035	10 x 35
P651325	13 x 25
P651328	13 x 28
P651330	13 x 30
P651335	13 x 35
P651625	16 x 25
P651628	16 x 28
P651630	16 x 30
P651635	16 x 35
P652025	20 x 25
P652028	20 x 28
P652030	20 x 30
P652035	20 x 35
P652225	22 x 25
P652228	22 x 28
P652230	22 x 30
P652235	22 x 35

NAAMS CODE	D x L
P652525	25 x 25
P652528	25 x 28
P652530	25 x 30
P652535	25 x 35
P653225	32 x 25
P653228	32 x 28
P653230	32 x 30
P653235	32 x 35
P653825	38 x 25
P653828	38 x 28
P653830	38 x 30
P653835	38 x 35
P654025	40 x 25
P654028	40 x 28
P654030	40 x 30
P654035	40 x 35
P654525	45 x 25
P654528	45 x 28
P654530	45 x 30
P654535	45 x 35
P655025	50 x 25
P655028	50 x 28
P655030	50 x 30
P655035	50 x 35

NAAMS CODE	D x L
P655625	56 x 25
P655628	56 x 28
P655630	56 x 30
P655635	56 x 35
P656325	63 x 25
P656328	63 x 28
P656330	63 x 30
P656335	63 x 35
P657125	71 x 25
P657128	71 x 28
P657130	71 x 30
P657135	71 x 35
P657625	76 x 25
P657628	76 x 28
P657630	76 x 30
P657635	76 x 35
P658525	85 x 25
P658528	85 x 28
P658530	85 x 30
P658535	85 x 35
P659025	90 x 25
P659028	90 x 28
P659030	90 x 30
P659035	90 x 35
P650025	100 x 25
P650028	100 x 28
P650030	100 x 30
P650035	100 x 35

CODING CONTINUED ON FOLLOWING PAGE

TAPERED RELIEF ROUND DIE BUTTON CODING

(P66 SERIES)



Stamping

04/16/96

Shape & Style: **P66** Body Dia.: **32** O.A. Length: **30** = SOLID ROUND ALT "A" x 32 BODY DIA. x 30 LG.

NAAMS CODE	D x L
P661325	13 x 25
P661328	13 x 28
P661330	13 x 30
P661335	13 x 35
P661625	16 x 25
P661628	16 x 28
P661630	16 x 30
P661635	16 x 35
P662025	20 x 25
P662028	20 x 28
P662030	20 x 30
P662035	20 x 35
P662225	22 x 25
P662228	22 x 28
P662230	22 x 30
P662235	22 x 35
P662525	25 x 25
P662528	25 x 28
P662530	25 x 30
P662535	25 x 35

NAAMS CODE	D x L
P663225	32 x 25
P663228	32 x 28
P663230	32 x 30
P663235	32 x 35
P663825	38 x 25
P663828	38 x 28
P663830	38 x 30
P663835	38 x 35
P664025	40 x 25
P664028	40 x 28
P664030	40 x 30
P664035	40 x 35
P664525	45 x 25
P664528	45 x 28
P664530	45 x 30
P664535	45 x 35
P665025	50 x 25
P665028	50 x 28
P665030	50 x 30
P665035	50 x 35
P665625	56 x 25
P665628	56 x 28
P665630	56 x 30
P665635	56 x 35

NAAMS CODE	D x L
P666325	63 x 25
P666328	63 x 28
P666330	63 x 30
P666335	63 x 35
P667125	71 x 25
P667128	71 x 28
P667130	71 x 30
P667135	71 x 35
P667625	76 x 25
P667628	76 x 28
P667630	76 x 30
P667635	76 x 35
P668525	85 x 25
P668528	85 x 28
P668530	85 x 30
P668535	85 x 35
P669025	90 x 25
P669028	90 x 28
P669030	90 x 30
P669035	90 x 35
P660025	100 x 25
P660028	100 x 28
P660030	100 x 30
P660035	100 x 35

CODING CONTINUED ON FOLLOWING PAGE

TAPERED RELIEF ROUND DIE BUTTON CODING

(P67 SERIES)

EX:	Shape & Style	Body Dia.	O. A. Length
	P67	32	30

= SOLID ROUND ALT "B" x 32 BODY DIA. x 30 LG.

NAAMS CODE	D x L
P671025	10 x 25
P671028	10 x 28
P671030	10 x 30
P671035	10 x 35
P671325	13 x 25
P671328	13 x 28
P671330	13 x 30
P671335	13 x 35
P671625	16 x 25
P671628	16 x 28
P671630	16 x 30
P671635	16 x 35
P672025	20 x 25
P672028	20 x 28
P672030	20 x 30
P672035	20 x 35
P672225	22 x 25
P672228	22 x 28
P672230	22 x 30
P672235	22 x 35

NAAMS CODE	D x L
P672525	25 x 25
P672528	25 x 28
P672530	25 x 30
P672535	25 x 35
P673225	32 x 25
P673228	32 x 28
P673230	32 x 30
P673235	32 x 35
P673825	38 x 25
P673828	38 x 28
P673830	38 x 30
P673835	38 x 35
P674025	40 x 25
P674028	40 x 28
P674030	40 x 30
P674035	40 x 35
P674525	45 x 25
P674528	45 x 28
P674530	45 x 30
P674535	45 x 35
P675025	50 x 25
P675028	50 x 28
P675030	50 x 30
P675035	50 x 35

NAAMS CODE	D x L
P675625	56 x 25
P675628	56 x 28
P675630	56 x 30
P675635	56 x 35
P676325	63 x 25
P676328	63 x 28
P676330	63 x 30
P676335	63 x 35
P677125	71 x 25
P677128	71 x 28
P677130	71 x 30
P677135	71 x 35
P677625	76 x 25
P677628	76 x 28
P677630	76 x 30
P677635	76 x 35
P678525	85 x 25
P678528	85 x 28
P678530	85 x 30
P678535	85 x 35
P679025	90 x 25
P679028	90 x 28
P679030	90 x 30
P679035	90 x 35
P670025	100 x 25
P670028	100 x 28
P670030	100 x 30
P670035	100 x 35

TAPERED RELIEF OBLONG DIE BUTTON

(P75 THRU P77 SERIES)

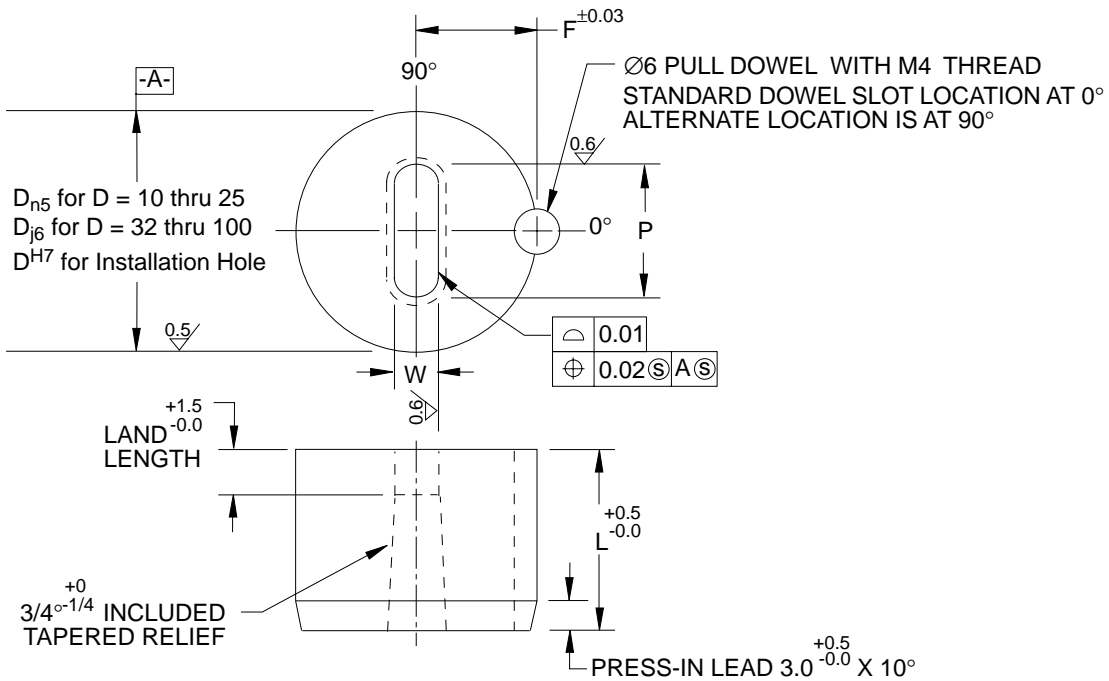

A

D STANDARD BODY Ø	HOLE SIZE RANGE 0.01 INCREMENTS		L OVERALL LENGTH				LAND LENGTHS			F
							STD	ALT	ALT	
	W	P	25	28	30	35	S	A	B	
10	1.30 to 6.70	1.40 to 6.80	x	x	x	x	5	8	3	7.00
13	1.90 to 8.70	2.00 to 8.80	x	x	x	x	5	8	3	8.20
16	1.90 to 10.70	2.00 to 10.80	x	x	x	x	5	8	3	9.00
20	1.90 to 13.50	2.00 to 13.60	x	x	x	x	5	10	3	11.00
22	1.90 to 14.90	2.00 to 15.00	x	x	x	x	6	10	3	12.00
25	1.90 to 16.90	2.00 to 17.00	x	x	x	x	6	10	3	13.50
32	1.90 to 21.90	2.00 to 22.00	x	x	x	x	6	12	3	16.00
38	1.90 to 26.90	2.00 to 27.00	x	x	x	x	8	12	3	19.00
40	1.90 to 26.90	2.00 to 27.00	x	x	x	x	8	12	3	20.00
45	2.40 to 30.90	2.50 to 31.00	x	x	x	x	8	12	3	22.50
50	4.00 to 33.90	4.10 to 34.00	x	x	x	x	8	12	3	25.00
56	4.00 to 37.90	4.10 to 38.00	x	x	x	x	8	12	3	28.00
63	4.00 to 42.90	4.10 to 43.00	x	x	x	x	8	12	3	31.50
71	4.00 to 47.90	4.10 to 48.00	x	x	x	x	8	12	3	35.50
76	5.60 to 51.90	5.70 to 52.00	x	x	x	x	8	12	3	38.00
85	5.60 to 57.90	5.70 to 58.00	x	x	x	x	8	12	3	42.50
90	5.60 to 60.90	5.70 to 61.00	x	x	x	x	8	12	3	45.00
100	5.60 to 67.90	5.70 to 68.00	x	x	x	x	8	12	3	50.00

NOTES & SPECIFICATIONS:

- Material, AISI – A2
- Hardness, Rc 60-63
- Identification, etch word “Metric” on each piece

CODING ON FOLLOWING PAGE

TAPERED RELIEF OBLONG DIE BUTTON CODING

(P75 SERIES)

EX:

Shape & Style	P75
------------------	-----

Body Dia.	32
-----------	----

O.A. Length	30
-------------	----

 = SOLID OBLONG STD. x 32 BODY DIA. x 30 LG.

NAAMS CODE	D x L
P751025	10 x 25
P751028	10 x 28
P751030	10 x 30
P751035	10 x 35
P751325	13 x 25
P751328	13 x 28
P751330	13 x 30
P751335	13 x 35
P751625	16 x 25
P751628	16 x 28
P751630	16 x 30
P751635	16 x 35
P752025	20 x 25
P752028	20 x 28
P752030	20 x 30
P752035	20 x 35
P752225	22 x 25
P752228	22 x 28
P752230	22 x 30
P752235	22 x 35
P752525	25 x 25
P752528	25 x 28
P752530	25 x 30
P752535	25 x 35

NAAMS CODE	D x L
P753225	32 x 25
P753228	32 x 28
P753230	32 x 30
P753235	32 x 35
P753825	38 x 25
P753828	38 x 28
P753830	38 x 30
P753835	38 x 35
P754025	40 x 25
P754028	40 x 28
P754030	40 x 30
P754035	40 x 35
P754525	45 x 25
P754528	45 x 28
P754530	45 x 30
P754535	45 x 35
P755025	50 x 25
P755028	50 x 28
P755030	50 x 30
P755035	50 x 35
P755625	56 x 25
P755628	56 x 28
P755630	56 x 30
P755635	56 x 35

NAAMS CODE	D x L
P756325	63 x 25
P756328	63 x 28
P756330	63 x 30
P756335	63 x 35
P757125	71 x 25
P757128	71 x 28
P757130	71 x 30
P757135	71 x 35
P757625	76 x 25
P757628	76 x 28
P757630	76 x 30
P757635	76 x 35
P758525	85 x 25
P758528	85 x 28
P758530	85 x 30
P758535	85 x 35
P759025	90 x 25
P759028	90 x 28
P759030	90 x 30
P759035	90 x 35
P750025	100 x 25
P750028	100 x 28
P750030	100 x 30
P750035	100 x 35

CODING CONTINUED ON FOLLOWING PAGE

TAPERED RELIEF OBLONG DIE BUTTON CODING

(P76 SERIES)

EX:

Shape & Style	P76
------------------	-----

Body Dia.	32
-----------	----

O.A. Length	30
-------------	----

 = SOLID OBLONG ALT "A" x 32 BODY DIA. x 30 LG.

NAAMS CODE	D x L
P761025	10 x 25
P761028	10 x 28
P761030	10 x 30
P761035	10 x 35
P761325	13 x 25
P761328	13 x 28
P761330	13 x 30
P761335	13 x 35
P761625	16 x 25
P761628	16 x 28
P761630	16 x 30
P761635	16 x 35
P762025	20 x 25
P762028	20 x 28
P762030	20 x 30
P762035	20 x 35
P762225	22 x 25
P762228	22 x 28
P762230	22 x 30
P762235	22 x 35
P762525	25 x 25
P762528	25 x 28
P762530	25 x 30
P762535	25 x 35

NAAMS CODE	D x L
P763225	32 x 25
P763228	32 x 28
P763230	32 x 30
P763235	32 x 35
P763825	38 x 25
P763828	38 x 28
P763830	38 x 30
P763835	38 x 35
P764025	40 x 25
P764028	40 x 28
P764030	40 x 30
P764035	40 x 35
P764525	45 x 25
P764528	45 x 28
P764530	45 x 30
P764535	45 x 35
P765025	50 x 25
P765028	50 x 28
P765030	50 x 30
P765035	50 x 35
P765625	56 x 25
P765628	56 x 28
P765630	56 x 30
P765635	56 x 35

NAAMS CODE	D x L
P766325	63 x 25
P766328	63 x 28
P766330	63 x 30
P766335	63 x 35
P767125	71 x 25
P767128	71 x 28
P767130	71 x 30
P767135	71 x 35
P767625	76 x 25
P767628	76 x 28
P767630	76 x 30
P767635	76 x 35
P768525	85 x 25
P768528	85 x 28
P768530	85 x 30
P768535	85 x 35
P769025	90 x 25
P769028	90 x 28
P769030	90 x 30
P769035	90 x 35
P760025	100 x 25
P760028	100 x 28
P760030	100 x 30
P760035	100 x 35

CODING CONTINUED ON FOLLOWING PAGE

TAPERED RELIEF OBLONG DIE BUTTON CODING

(P77 SERIES)

EX:

Pnt. Style	P77
---------------	-----

Body Dia.	32
-----------	----

O.A. Length	30
-------------	----

 = SOLID OBLONG ALT "B" x 32 BODY DIA. x 30 LG.

NAAMS CODE	D x L
P771025	10 x 25
P771028	10 x 28
P771030	10 x 30
P771035	10 x 35
P771325	13 x 25
P771328	13 x 28
P771330	13 x 30
P771335	13 x 35
P771625	16 x 25
P771628	16 x 28
P771630	16 x 30
P771635	16 x 35
P772025	20 x 25
P772028	20 x 28
P772030	20 x 30
P772035	20 x 35
P772225	22 x 25
P772228	22 x 28
P772230	22 x 30
P772235	22 x 35
P772525	25 x 25
P772528	25 x 28
P772530	25 x 30
P772535	25 x 35

NAAMS CODE	D x L
P773225	32 x 25
P773228	32 x 28
P773230	32 x 30
P773235	32 x 35
P773825	38 x 25
P773828	38 x 28
P773830	38 x 30
P773835	38 x 35
P774025	40 x 25
P774028	40 x 28
P774030	40 x 30
P774035	40 x 35
P774525	45 x 25
P774528	45 x 28
P774530	45 x 30
P774535	45 x 35
P775025	50 x 25
P775028	50 x 28
P775030	50 x 30
P775035	50 x 35
P775625	56 x 25
P775628	56 x 28
P775630	56 x 30
P775635	56 x 35

NAAMS CODE	D x L
P776325	63 x 25
P776328	63 x 28
P776330	63 x 30
P776335	63 x 35
P777125	71 x 25
P777128	71 x 28
P777130	71 x 30
P777135	71 x 35
P777625	76 x 25
P777628	76 x 28
P777630	76 x 30
P777635	76 x 35
P778525	85 x 25
P778528	85 x 28
P778530	85 x 30
P778535	85 x 35
P779025	90 x 25
P779028	90 x 28
P779030	90 x 30
P779035	90 x 35
P770025	100 x 25
P770028	100 x 28
P770030	100 x 30
P770035	100 x 35

TAPERED RELIEF SQUARE DIE BUTTON

(P85 THRU P87 SERIES)

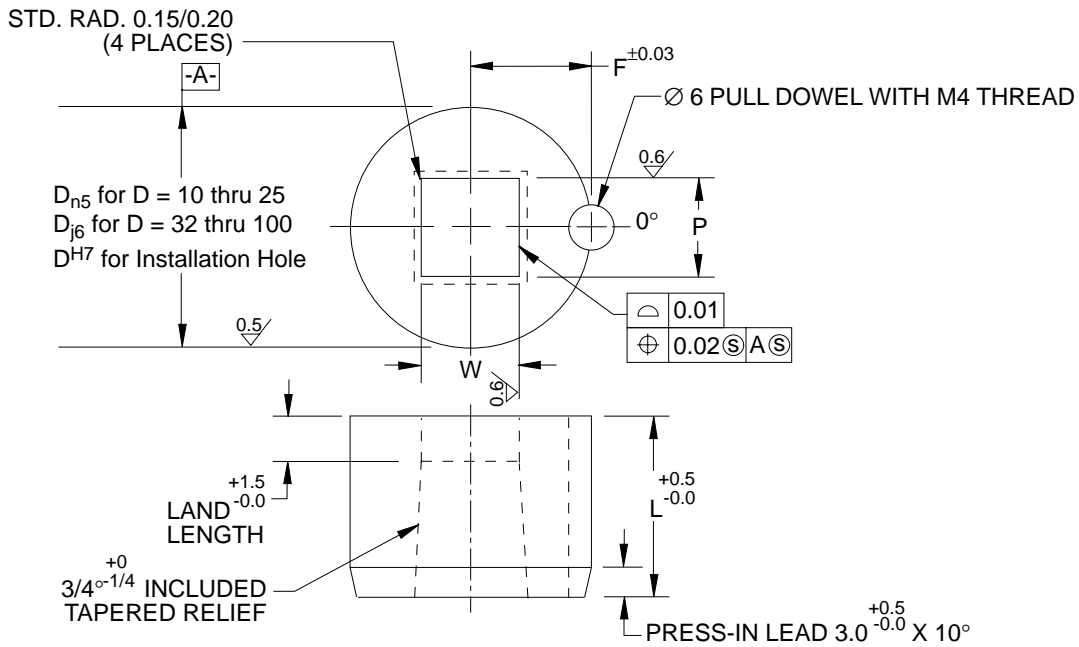

A

D STANDARD BODY Ø	P=W HOLE SIZE RANGE 0.01 INCREMENTS		L OVERALL LENGTH				LAND LENGTHS			F
			25	28	30	35	STD	ALT	ALT	
							S	A	B	
10	1.30	to 4.80	x	x	x	x	5	8	3	7.00
13	1.90	to 6.20	x	x	x	x	5	8	3	8.20
16	1.90	to 7.60	x	x	x	x	5	8	3	9.00
20	1.90	to 9.60	x	x	x	x	5	10	3	11.00
22	1.90	to 10.60	x	x	x	x	6	10	3	12.00
25	1.90	to 12.00	x	x	x	x	6	10	3	13.50
32	1.90	to 15.50	x	x	x	x	6	12	3	16.00
38	1.90	to 19.10	x	x	x	x	8	12	3	19.00
40	1.90	to 19.10	x	x	x	x	8	12	3	20.00
45	2.40	to 21.90	x	x	x	x	8	12	3	22.50
50	4.00	to 24.00	x	x	x	x	8	12	3	25.00
56	4.00	to 26.90	x	x	x	x	8	12	3	28.00
63	4.00	to 30.40	x	x	x	x	8	12	3	31.50
71	4.00	to 34.00	x	x	x	x	8	12	3	35.50
76	5.60	to 36.80	x	x	x	x	8	12	3	38.00
85	5.60	to 41.00	x	x	x	x	8	12	3	42.50
90	5.60	to 43.10	x	x	x	x	8	12	3	45.00
100	5.60	to 48.10	x	x	x	x	8	12	3	50.00

NOTES & SPECIFICATIONS:

- Material, AISI – A2
- Hardness, Rc 60-63
- Identification, etch word “Metric” on each piece

CODING ON FOLLOWING PAGE

TAPERED RELIEF SQUARE DIE BUTTON CODING

(P85 SERIES)

EX:	Shape & Style	Body Dia.	O.A. Length
	P85	32	30
	= SOLID SQUARE STD. x 32 BODY DIA. x 30 LG.		

NAAMS CODE	D x L
P851025	10 x 25
P851028	10 x 28
P851030	10 x 30
P851035	10 x 35
P851325	13 x 25
P851328	13 x 28
P851330	13 x 30
P851335	13 x 35
P851625	16 x 25
P851628	16 x 28
P851630	16 x 30
P851635	16 x 35
P852025	20 x 25
P852028	20 x 28
P852030	20 x 30
P852035	20 x 35
P852225	22 x 25
P852228	22 x 28
P852230	22 x 30
P852235	22 x 35
P852525	25 x 25
P852528	25 x 28
P852530	25 x 30
P852535	25 x 35

NAAMS CODE	D x L
P853225	32 x 25
P853228	32 x 28
P853230	32 x 30
P853235	32 x 35
P853825	38 x 25
P853828	38 x 28
P853830	38 x 30
P853835	38 x 35
P854025	40 x 25
P854028	40 x 28
P854030	40 x 30
P854035	40 x 35
P854525	45 x 25
P854528	45 x 28
P854530	45 x 30
P854535	45 x 35
P855025	50 x 25
P855028	50 x 28
P855030	50 x 30
P855035	50 x 35
P855625	56 x 25
P855628	56 x 28
P855630	56 x 30
P855635	56 x 35

NAAMS CODE	D x L
P856325	63 x 25
P856328	63 x 28
P856330	63 x 30
P856335	63 x 35
P857125	71 x 25
P857128	71 x 28
P857130	71 x 30
P857135	71 x 35
P857625	76 x 25
P857628	76 x 28
P857630	76 x 30
P857635	76 x 35
P858525	85 x 25
P858528	85 x 28
P858530	85 x 30
P858535	85 x 35
P859025	90 x 25
P859028	90 x 28
P859030	90 x 30
P859035	90 x 35
P850025	100 x 25
P850028	100 x 28
P850030	100 x 30
P850035	100 x 35

CODING CONTINUED ON FOLLOWING PAGE

TAPERED RELIEF SQUARE DIE BUTTON CODING

(P86 SERIES)



Stamping

04/16/96

EX:	Shape & Style	Body Dia.	O.A. Length
	P86	32	30

= SOLID SQUARE ALT "A" x 32 BODY DIA. x 30 LG.

NAAMS CODE	D x L
P861025	10 x 25
P861028	10 x 28
P861030	10 x 30
P861035	10 x 35
P861325	13 x 25
P861328	13 x 28
P861330	13 x 30
P861335	13 x 35
P861625	16 x 25
P861628	16 x 28
P861630	16 x 30
P861635	16 x 35
P862025	20 x 25
P862028	20 x 28
P862030	20 x 30
P862035	20 x 35
P862225	22 x 25
P862228	22 x 28
P862230	22 x 30
P862235	22 x 35
P862525	25 x 25
P862528	25 x 28
P862530	25 x 30
P862535	25 x 35

NAAMS CODE	D x L
P863225	32 x 25
P863228	32 x 28
P863230	32 x 30
P863235	32 x 35
P863825	38 x 25
P863828	38 x 28
P863830	38 x 30
P863835	38 x 35
P864025	40 x 25
P864028	40 x 28
P864030	40 x 30
P864035	40 x 35
P864525	45 x 25
P864528	45 x 28
P864530	45 x 30
P864535	45 x 35
P865025	50 x 25
P865028	50 x 28
P865030	50 x 30
P865035	50 x 35
P865625	56 x 25
P865628	56 x 28
P865630	56 x 30
P865635	56 x 35

NAAMS CODE	D x L
P866325	63 x 25
P866328	63 x 28
P866330	63 x 30
P866335	63 x 35
P867125	71 x 25
P867128	71 x 28
P867130	71 x 30
P867135	71 x 35
P867625	76 x 25
P867628	76 x 28
P867630	76 x 30
P867635	76 x 35
P868525	85 x 25
P868528	85 x 28
P868530	85 x 30
P868535	85 x 35
P869025	90 x 25
P869028	90 x 28
P869030	90 x 30
P869035	90 x 35
P860025	100 x 25
P860028	100 x 28
P860030	100 x 30
P860035	100 x 35

CODING CONTINUED ON FOLLOWING PAGE

TAPERED RELIEF SQUARE DIE BUTTON CODING

(P87 SERIES)

EX:	Shape & Style	Body Dia.	O. A. Length
	P87	32	30

= SOLID SQUARE ALT "B" x 32 BODY DIA. x 30 LG.

NAAMS CODE	D x L
P871025	10 x 25
P871028	10 x 28
P871030	10 x 30
P871035	10 x 35
P871325	13 x 25
P871328	13 x 28
P871330	13 x 30
P871335	13 x 35
P871625	16 x 25
P871628	16 x 28
P871630	16 x 30
P871635	16 x 35
P872025	20 x 25
P872028	20 x 28
P872030	20 x 30
P872035	20 x 35
P872225	22 x 25
P872228	22 x 28
P872230	22 x 30
P872235	22 x 35
P872525	25 x 25
P872528	25 x 28
P872530	25 x 30
P872535	25 x 35

NAAMS CODE	D x L
P873225	32 x 25
P873228	32 x 28
P873230	32 x 30
P873235	32 x 35
P873825	38 x 25
P873828	38 x 28
P873830	38 x 30
P873835	38 x 35
P874025	40 x 25
P874028	40 x 28
P874030	40 x 30
P874035	40 x 35
P874525	45 x 25
P874528	45 x 28
P874530	45 x 30
P874535	45 x 35
P875025	50 x 25
P875028	50 x 28
P875030	50 x 30
P875035	50 x 35
P875625	56 x 25
P875628	56 x 28
P875630	56 x 30
P875635	56 x 35

NAAMS CODE	D x L
P876325	63 x 25
P876328	63 x 28
P876330	63 x 30
P876335	63 x 35
P877125	71 x 25
P877128	71 x 28
P877130	71 x 30
P877135	71 x 35
P877625	76 x 25
P877628	76 x 28
P877630	76 x 30
P877635	76 x 35
P878525	85 x 25
P878528	85 x 28
P878530	85 x 30
P878535	85 x 35
P879025	90 x 25
P879028	90 x 28
P879030	90 x 30
P879035	90 x 35
P870025	100 x 25
P870028	100 x 28
P870030	100 x 30
P870035	100 x 35

TAPERED RELIEF RECTANGULAR DIE BUTTON

(P95 THRU P97 SERIES)

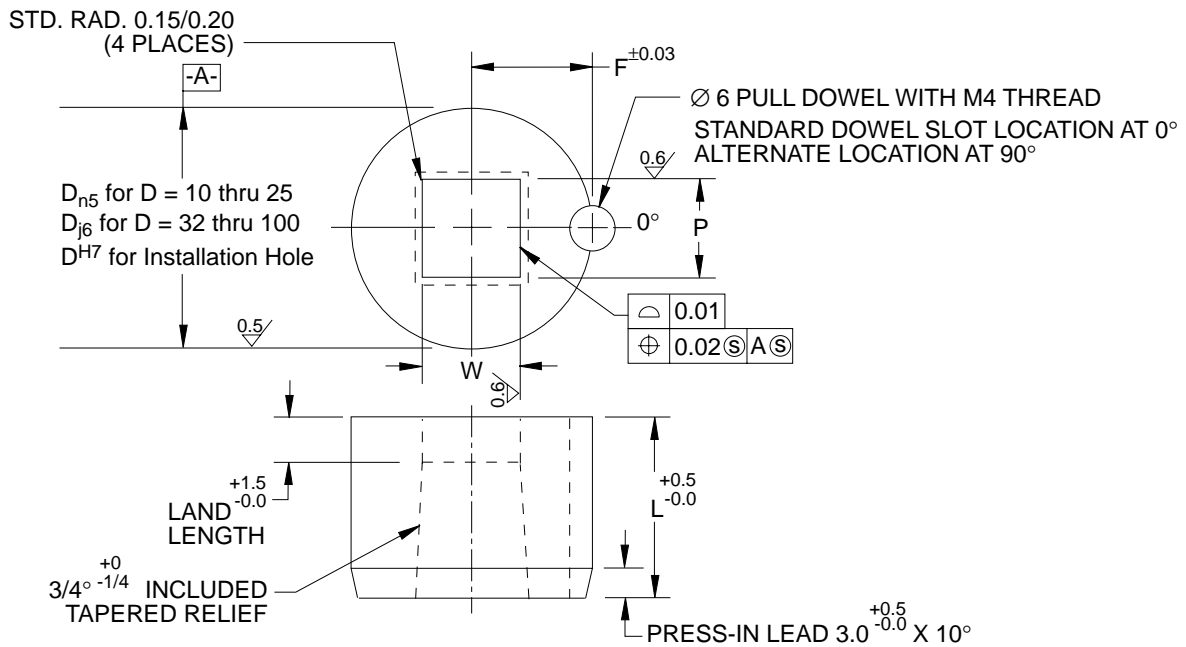

D STANDARD BODY Ø	HOLE SIZE RANGE 0.01 INCREMENTS		L OVERALL LENGTH				LAND LENGTHS			F
							STD	ALT	ALT	
	W	P	25	28	30	35	S	A	B	
10	1.30 to 4.00	1.40 to 5.50	x	x	x	x	5	8	3	7.00
13	1.90 to 5.30	2.00 to 7.00	x	x	x	x	5	8	3	8.20
16	1.90 to 6.70	2.00 to 8.50	x	x	x	x	5	8	3	9.00
20	1.90 to 8.00	2.00 to 11.00	x	x	x	x	5	10	3	11.00
22	1.90 to 8.30	2.00 to 12.50	x	x	x	x	6	10	3	12.00
25	1.90 to 8.80	2.00 to 14.50	x	x	x	x	6	10	3	13.50
32	1.90 to 12.60	2.00 to 18.00	x	x	x	x	6	12	3	16.00
38	1.90 to 14.10	2.00 to 23.00	x	x	x	x	8	12	3	19.00
40	1.90 to 14.10	2.00 to 23.00	x	x	x	x	8	12	3	20.00
45	2.40 to 21.00	2.50 to 28.00	x	x	x	x	8	12	3	22.50
50	4.00 to 22.60	4.10 to 33.00	x	x	x	x	8	12	3	25.00
56	4.00 to 24.10	4.10 to 38.00	x	x	x	x	8	12	3	28.00
63	4.00 to 26.30	4.10 to 42.50	x	x	x	x	8	12	3	31.50
71	4.00 to 28.80	4.10 to 48.00	x	x	x	x	8	12	3	35.50
76	5.60 to 31.60	5.70 to 51.00	x	x	x	x	8	12	3	38.00
85	5.60 to 34.90	5.70 to 56.00	x	x	x	x	8	12	3	42.50
90	5.60 to 36.00	5.70 to 60.00	x	x	x	x	8	12	3	45.00
100	5.60 to 41.50	5.70 to 66.00	x	x	x	x	8	12	3	50.00

NOTES & SPECIFICATIONS:

- Material, AISI – A2
- Hardness, Rc 60-63
- Identification, etch word "Metric" on each piece

CODING ON FOLLOWING PAGE

TAPERED RELIEF RECTANGULAR DIE BUTTON CODE

(P95 SERIES)



Stamping

04/16/96

EX:	Shape & Style	Body Dia.	O. A. Length
	P95	32	30

= SOLID RECTANGULAR STD. x 32 BODY DIA. x 30 LG.

NAAMS CODE	D x L
P951025	10 x 25
P951028	10 x 28
P951030	10 x 30
P951035	10 x 35
P951325	13 x 25
P951328	13 x 28
P951330	13 x 30
P951335	13 x 35
P951625	16 x 25
P951628	16 x 28
P951630	16 x 30
P951635	16 x 35
P952025	20 x 25
P952028	20 x 28
P952030	20 x 30
P952035	20 x 35
P952225	22 x 25
P952228	22 x 28
P952230	22 x 30
P952235	22 x 35
P952525	25 x 25
P952528	25 x 28
P952530	25 x 30
P952535	25 x 35

NAAMS CODE	D x L
P953225	32 x 25
P953228	32 x 28
P953230	32 x 30
P953235	32 x 35
P953825	38 x 25
P953828	38 x 28
P953830	38 x 30
P953835	38 x 35
P954025	40 x 25
P954028	40 x 28
P954030	40 x 30
P954035	40 x 35
P954525	45 x 25
P954528	45 x 28
P954530	45 x 30
P954535	45 x 35
P955025	50 x 25
P955028	50 x 28
P955030	50 x 30
P955035	50 x 35
P955625	56 x 25
P955628	56 x 28
P955630	56 x 30
P955635	56 x 35

NAAMS CODE	D x L
P956325	63 x 25
P956328	63 x 28
P956330	63 x 30
P956335	63 x 35
P957125	71 x 25
P957128	71 x 28
P957130	71 x 30
P957135	71 x 35
P957625	76 x 25
P957628	76 x 28
P957630	76 x 30
P957635	76 x 35
P958525	85 x 25
P958528	85 x 28
P958530	85 x 30
P958535	85 x 35
P959025	90 x 25
P959028	90 x 28
P959030	90 x 30
P959035	90 x 35
P950025	100 x 25
P950028	100 x 28
P950030	100 x 30
P950035	100 x 35

CODING CONTINUED ON FOLLOWING PAGE

TAPERED RELIEF RECTANGULAR DIE BUTTON CODING

(P96 SERIES)



Stamping

04/16/96

EX:	Shape & Style	Body Dia.	O.A. Length
	P96	32	30

= SOLID RECTANGULAR ALT "A" x 32 BODY DIA. x 30 LG.

NAAMS CODE	D x L
P961025	10 x 25
P961028	10 x 28
P961030	10 x 30
P961035	10 x 35
P961325	13 x 25
P961328	13 x 28
P961330	13 x 30
P961335	13 x 35
P961625	16 x 25
P961628	16 x 28
P961630	16 x 30
P961635	16 x 35
P962025	20 x 25
P962028	20 x 28
P962030	20 x 30
P962035	20 x 35
P962225	22 x 25
P962228	22 x 28
P962230	22 x 30
P962235	22 x 35
P962525	25 x 25
P962528	25 x 28
P962530	25 x 30
P962535	25 x 35

NAAMS CODE	D x L
P963225	32 x 25
P963228	32 x 28
P963230	32 x 30
P963235	32 x 35
P963825	38 x 25
P963828	38 x 28
P963830	38 x 30
P963835	38 x 35
P964025	40 x 25
P964028	40 x 28
P964030	40 x 30
P964035	40 x 35
P964525	45 x 25
P964528	45 x 28
P964530	45 x 30
P964535	45 x 35
P965025	50 x 25
P965028	50 x 28
P965030	50 x 30
P965035	50 x 35
P965625	56 x 25
P965628	56 x 28
P965630	56 x 30
P965635	56 x 35

NAAMS CODE	D x L
P966325	63 x 25
P966328	63 x 28
P966330	63 x 30
P966335	63 x 35
P967125	71 x 25
P967128	71 x 28
P967130	71 x 30
P967135	71 x 35
P967625	76 x 25
P967628	76 x 28
P967630	76 x 30
P967635	76 x 35
P968525	85 x 25
P968528	85 x 28
P968530	85 x 30
P968535	85 x 35
P969025	90 x 25
P969028	90 x 28
P969030	90 x 30
P969035	90 x 35
P960025	100 x 25
P960028	100 x 28
P960030	100 x 30
P960035	100 x 35

CODING CONTINUED ON FOLLOWING PAGE

TAPERED RELIEF RECTANGULAR DIE BUTTON CODING

(P97 SERIES)



Stamping

04/16/96

EX:	Shape & Style	Body Dia.	O.A. Length
	P97	32	30

= SOLID RECTANGULAR ALT "B" x 32 BODY DIA. x 30 LG.

NAAMS CODE	D x L
P971025	10 x 25
P971028	10 x 28
P971030	10 x 30
P971035	10 x 35
P971325	13 x 25
P971328	13 x 28
P971330	13 x 30
P971335	13 x 35
P971625	16 x 25
P971628	16 x 28
P971630	16 x 30
P971635	16 x 35
P972025	20 x 25
P972028	20 x 28
P972030	20 x 30
P972035	20 x 35
P972225	22 x 25
P972228	22 x 28
P972230	22 x 30
P972235	22 x 35
P972525	25 x 25
P972528	25 x 28
P972530	25 x 30
P972535	25 x 35

NAAMS CODE	D x L
P973225	32 x 25
P973228	32 x 28
P973230	32 x 30
P973235	32 x 35
P973825	38 x 25
P973828	38 x 28
P973830	38 x 30
P973835	38 x 35
P974025	40 x 25
P974028	40 x 28
P974030	40 x 30
P974035	40 x 35
P974525	45 x 25
P974528	45 x 28
P974530	45 x 30
P974535	45 x 35
P975025	50 x 25
P975028	50 x 28
P975030	50 x 30
P975035	50 x 35
P975625	56 x 25
P975628	56 x 28
P975630	56 x 30
P975635	56 x 35

NAAMS CODE	D x L
P976325	63 x 25
P976328	63 x 28
P976330	63 x 30
P976335	63 x 35
P977125	71 x 25
P977128	71 x 28
P977130	71 x 30
P977135	71 x 35
P977625	76 x 25
P977628	76 x 28
P977630	76 x 30
P977635	76 x 35
P978525	85 x 25
P978528	85 x 28
P978530	85 x 30
P978535	85 x 35
P979025	90 x 25
P979028	90 x 28
P979030	90 x 30
P979035	90 x 35
P970025	100 x 25
P970028	100 x 28
P970030	100 x 30
P970035	100 x 35

PIERCE AND EXTRUDE BALL LOCK PUNCH

(P51, P52, P53 SERIES)

(HEAVY DUTY)

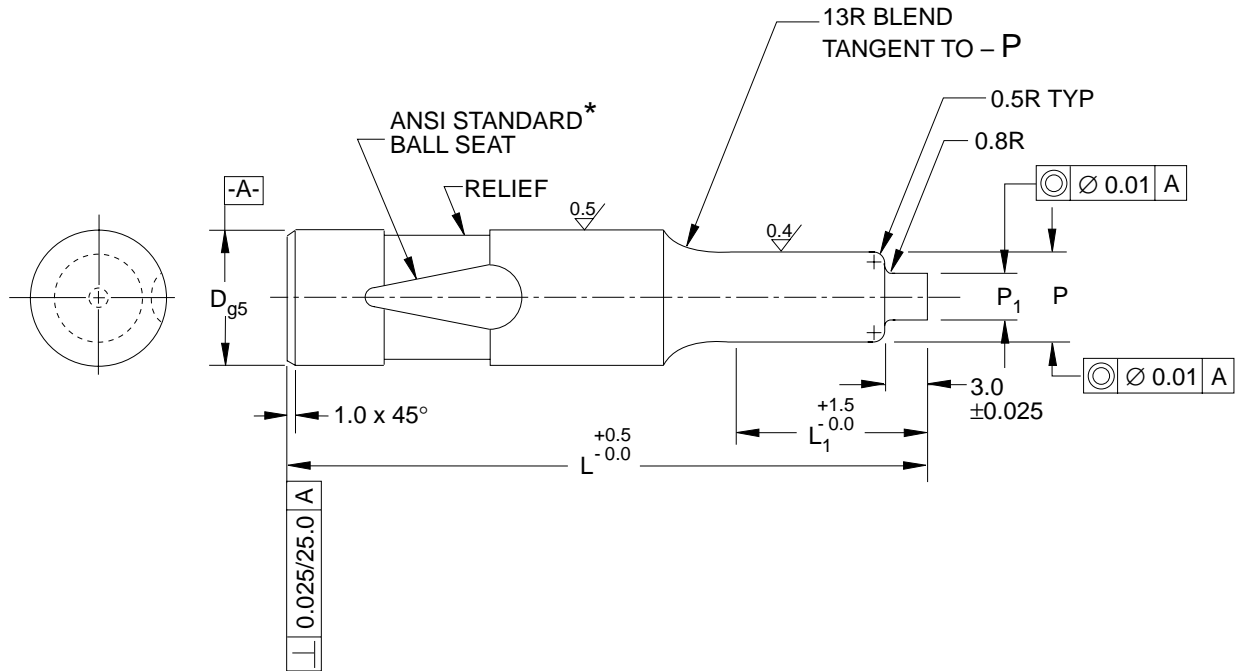

D NOMINAL SHANK Ø	PUNCH POINTS AVAILABLE 0.01 INCREMENTS		L OVERALL LENGTH	L1 POINT LENGTH			PUNCH RETAINER NAAMS CODE
	P	P1		STD.	ALT A	ALT B	
10	3.0 to 9.9	1.5 to 7.0	80 90 100	19	10	–	P010010
13	5.0 to 12.9	2.5 to 9.0		19	13	–	P010013
16	8.0 to 15.9	4.0 to 11.5		19	13	25	P010016
20	12.0 to 19.9	6.0 to 14.0		19	13	25	P010020
25	16.0 to 24.9	8.0 to 17.5		19	13	25	P010025
32	24.0 to 31.9	12.0 to 22.5		19	13	25	P010032
40	30.0 to 39.9	15.0 to 28.0		25	19	30	P010040

NOTES & SPECIFICATIONS:

Material, AISI-M2.

Hardness, Rc 60-63. Triple temper.

Identification, etch the word "Metric" on each piece.

* Ball Seat must conform to ANSI Standard gages for locking location.

When P-P1 is less than 2.3 per side, reduce radius sizes keeping the 2:1 ratio.

PIERCE AND EXTRUDE BALL LOCK PUNCH CODING

(P51, P52, P53 SERIES)



Stamping

05/14/97

Shape & Point Length Style	P52
----------------------------	-----

Shank Dia.	25
------------	----

O.A. Length	90
-------------	----

 = PIERCE & EXTRUDE, ALT A, 25 SHANK X 90 LG.

P51 = STD.
 P52 = ALT. "A"
 P53 = ALT. "B"

P51

NAAMS CODE	D x L
P511080	10 x 80
P511380	13 x 80
P511680	16 x 80
P512080	20 x 80
P512580	25 x 80
P513280	32 x 80
P514080	40 x 80
P511090	10 x 90
P511390	13 x 90
P511690	16 x 90
P512090	20 x 90
P512590	25 x 90
P513290	32 x 90
P514090	40 x 90
P511000	10 x 100
P511300	13 x 100
P511600	16 x 100
P512000	20 x 100
P512500	25 x 100
P513200	32 x 100
P514000	40 x 100

P52

NAAMS CODE	D x L
P521080	10 x 80
P521380	13 x 80
P521680	16 x 80
P522080	20 x 80
P522580	25 x 80
P523280	32 x 80
P524080	40 x 80
P521090	10 x 90
P521390	13 x 90
P521690	16 x 90
P522090	20 x 90
P522590	25 x 90
P523290	32 x 90
P524090	40 x 90
P521000	10 x 100
P521300	13 x 100
P521600	16 x 100
P522000	20 x 100
P522500	25 x 100
P523200	32 x 100
P524000	40 x 100

P53

NAAMS CODE	D x L
P531680	16 x 80
P532080	20 x 80
P532580	25 x 80
P533280	32 x 80
P534080	40 x 80
P531690	16 x 90
P532090	20 x 90
P532590	25 x 90
P533290	32 x 90
P534090	40 x 90
P531600	16 x 100
P532000	20 x 100
P532500	25 x 100
P533200	32 x 100
P534000	40 x 100

ROUND POINT LARGER BALL LOCK PUNCH

(P13 STANDARD – P14 ALTERNATE)

GLOBAL STANDARD COMPONENTS



Stamping

04/24/14

(HEAVY DUTY)

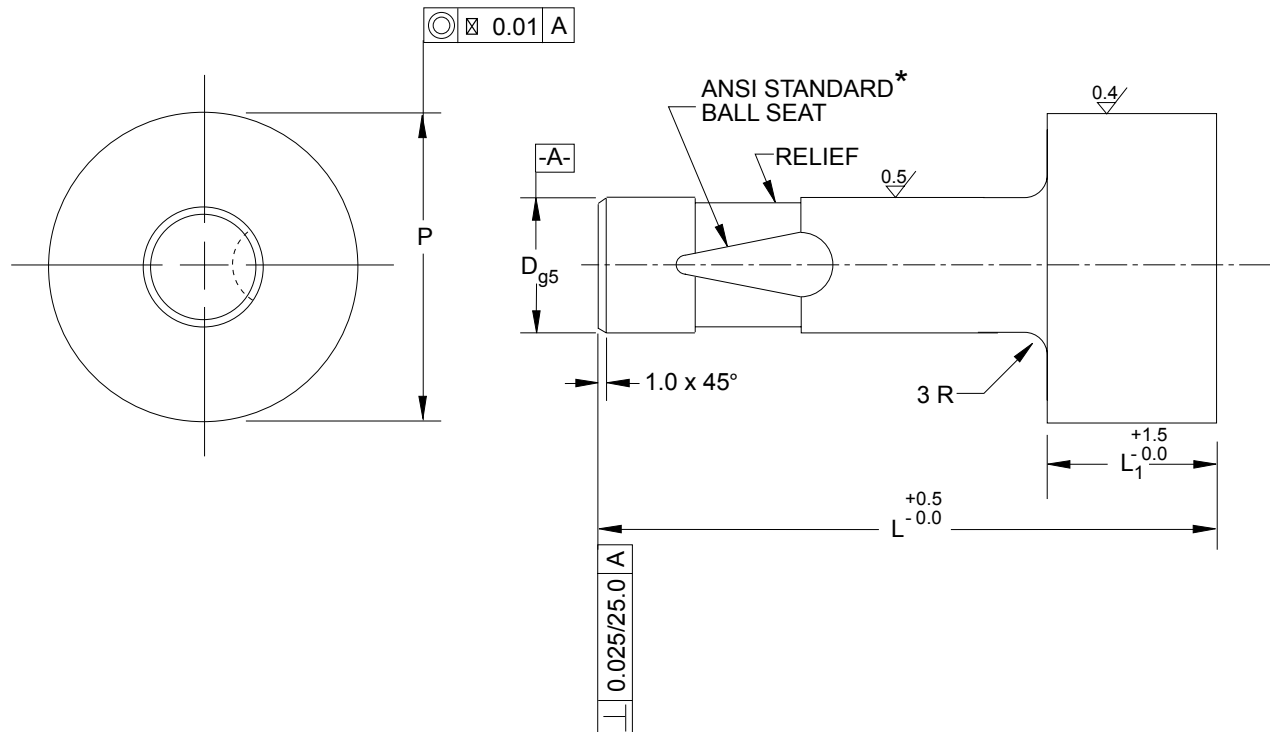

D NOMINAL SHANK Ø	P PUNCH POINTS AVAILABLE 0.01 INCREMENTS	L OVERALL LENGTH				L1 POINT LENGTH		PUNCH RETAINER NAAMS CODE
		71	80	90	100	P13 STD.	P14 ALT	
10	10.1 to 25.0	X	X	X	X	16	30	P010010
13	13.1 to 32.0	X	X	X	X	19	30	P010013
16	16.1 to 38.0	X	X	X	X	19	30	P010016
20	20.1 to 40.0	X	X	X	X	19	30	P010020
25	25.1 to 47.0	X	X	X	X	19	30	P010025
32	32.1 to 63.0	X	X	X	X	19	30	P010032
40	40.1 to 63.0	X	X	X	X	19	30	P010040

NOTES & SPECIFICATIONS:

Material, AISI-M2.

Hardness, Rc 60-63. Triple temper.

Identification, etch the word "Metric" on each piece.

* Ball Seat must conform to ANSI Standard gages for locking location.

CODING ON FOLLOWING PAGE

A

ROUND POINT LARGER BALL LOCK PUNCH

(P13 STANDARD – P14 ALTERNATE)

P13 STANDARD	
NAAMS CODE NO.	D X L
P131380	13 X 80
P131680	16 X 80
P132080	20 X 80
P132580	25 X 80
P133280	32 X 80
P134080	40 X 80
P131390	13 X 90
P131690	16 X 90
P132090	20 X 90
P132590	25 X 90
P133290	32 X 90
P134090	40 X 90
P131300	13 X 100
P131600	16 X 100
P132000	20 X 100
P132500	25 X 100
P133200	32 X 100
P134000	40 X 100

P14 ALTERNATE	
NAAMS CODE NO.	D X L
P141380	13 X 80
P141680	16 X 80
P142080	20 X 80
P142580	25 X 80
P143280	32 X 80
P144080	40 X 80
P141390	13 X 90
P141690	16 X 90
P142090	20 X 90
P142590	25 X 90
P143290	32 X 90
P144090	40 X 90
P141300	13 X 100
P141600	16 X 100
P142000	20 X 100
P142500	25 X 100
P143200	32 X 100
P144000	40 X 100

OBLONG POINT LARGER BALL LOCK PUNCH

(P23 STANDARD – P24 ALTERNATE)

GLOBAL STANDARD COMPONENTS



Stamping

04/24/14

(HEAVY DUTY)

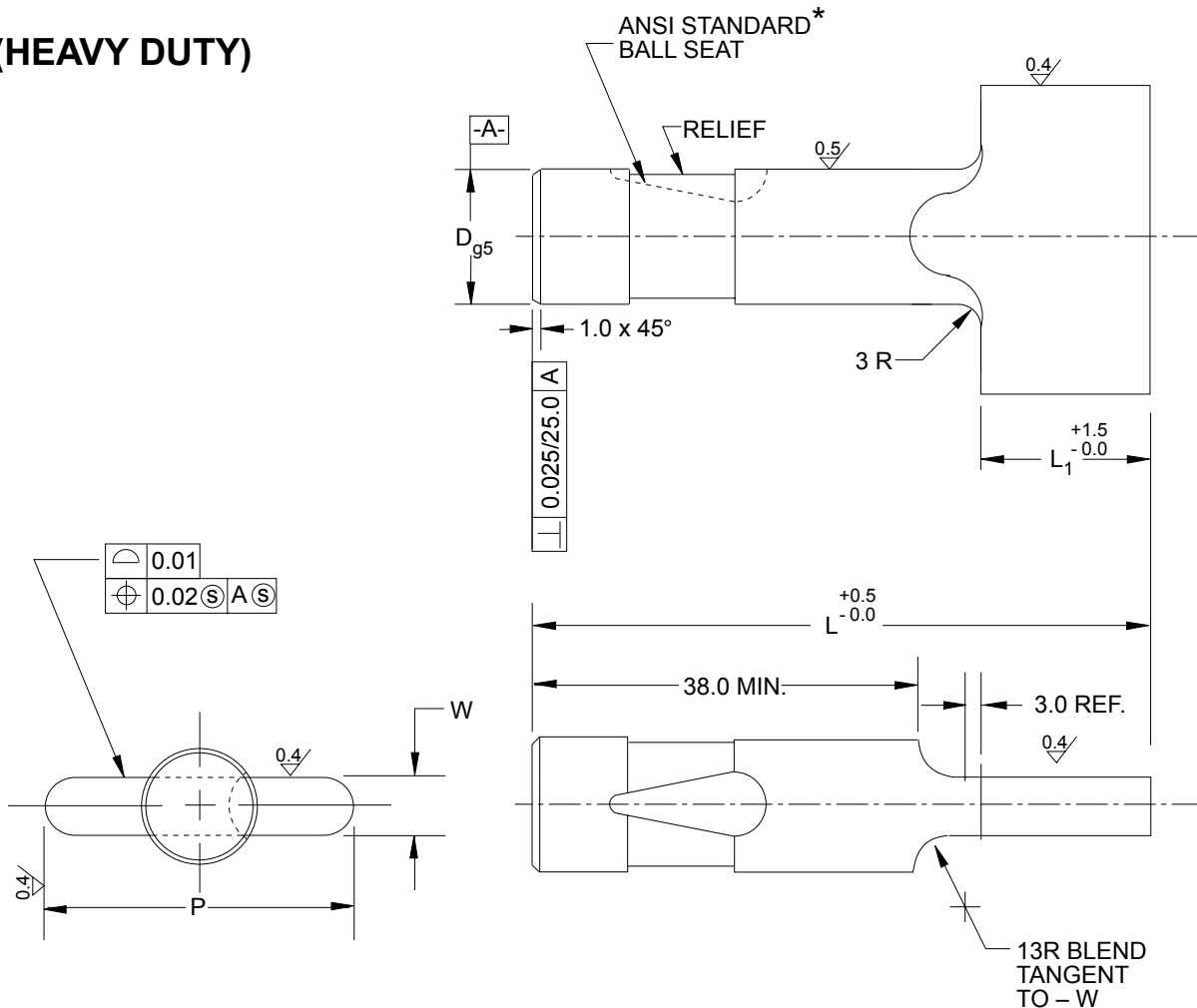

D NOMINAL SHANK Ø	PUNCH POINTS AVAILABLE 0.01 INCREMENTS		L OVERALL LENGTH				L1 POINT LENGTH		PUNCH RETAINER NAAMS CODE
	W MIN	P MAX	71	80	90	100	P23 STD.	P2 ALT	
10	3.0	25.0	X	X	X	X	16	30	P010010
13	5.0	32.0	X	X	X	X	19	30	P010013
16	6.0	38.0	X	X	X	X	19	30	P010016
20	8.0	40.0	X	X	X	X	19	30	P010020
25	10.0	47.0	X	X	X	X	19	30	P010025
32	11.5	63.0		X	X	X	19	30	P010032
40	14.0	63.0		X	X	X	19	30	P010040

NOTES & SPECIFICATIONS:

- Material, AISI-M2.
- Hardness, Rc 60-63. Triple temper.
- Identification, etch the word "Metric" on each piece.
- * Ball Seat must conform to ANSI Standard gages for locking location.

CODING ON FOLLOWING PAGE

A

OBLONG POINT LARGER BALL LOCK PUNCH

(P23 STANDARD – P24 ALTERNATE)



Stamping

10/30/96

P23 STANDARD	
NAAMS CODE NO.	D X L
P231380	13 X 80
P231680	16 X 80
P232080	20 X 80
P232580	25 X 80
P233280	32 X 80
P234080	40 X 80
P231390	13 X 90
P231690	16 X 90
P232090	20 X 90
P232590	25 X 90
P233290	32 X 90
P234090	40 X 90
P231300	13 X 100
P231600	16 X 100
P232000	20 X 100
P232500	25 X 100
P233200	32 X 100
P234000	40 X 100

P24 ALTERNATE	
NAAMS CODE NO.	D X L
P241380	13 X 80
P241680	16 X 80
P242080	20 X 80
P242580	25 X 80
P243280	32 X 80
P244080	40 X 80
P241390	13 X 90
P241690	16 X 90
P242090	20 X 90
P242590	25 X 90
P243290	32 X 90
P244090	40 X 90
P241300	13 X 100
P241600	16 X 100
P242000	20 X 100
P242500	25 X 100
P243200	32 X 100
P244000	40 X 100

SQUARE POINT LARGER BALL LOCK PUNCH

(P33 STANDARD – P34 ALTERNATE)

(HEAVY DUTY)

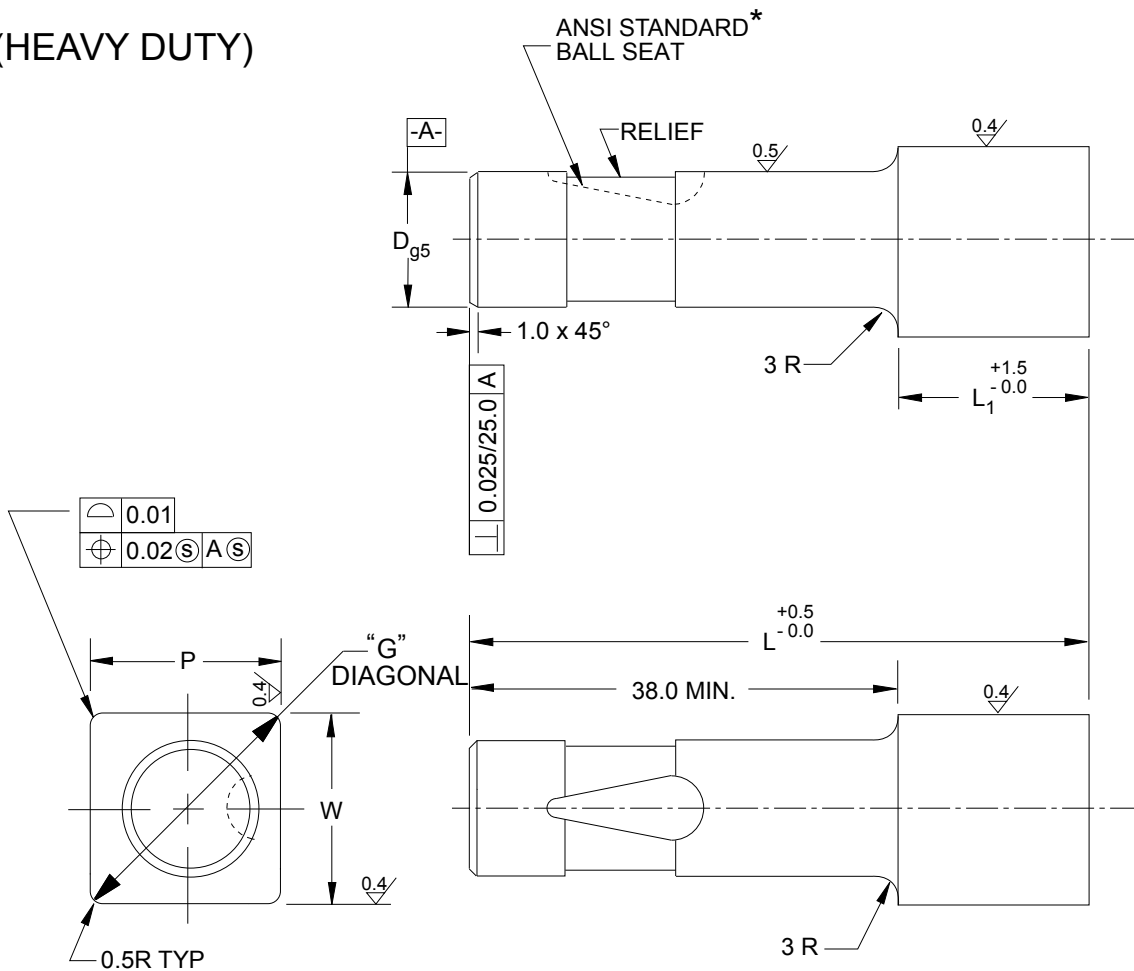

D NOMINAL SHANK Ø	PUNCH POINTS AVAILABLE 0.01 INCREMENTS		L OVERALL LENGTH				L1 POINT LENGTH		PUNCH RETAINER NAAMS CODE
	W MIN	G MAX	71	80	90	100	P33 STD.	P34 ALT	
10	3.0	25.0	X	X	X	X	16	30	P010010
13	5.0	32.0	X	X	X	X	19	30	P010013
16	6.0	38.0	X	X	X	X	19	30	P010016
20	8.0	40.0	X	X	X	X	19	30	P010020
25	10.0	47.0	X	X	X	X	19	30	P010025
32	11.50	63.0		X	X	X	19	30	P010032
40	14.0	63.0		X	X	X	19	30	P010040

$$G = 2\sqrt{(P/2-R)^2 + (W/2-R)^2} + R$$

NOTES & SPECIFICATIONS: $G_{MAX} = D - 0.2$

Material, AISI-M2.

Hardness, Rc 60-63. Triple temper.

Identification, etch the word "Metric" on each piece.

* Ball Seat must conform to ANSI Standard gages for locking location.

CODING ON FOLLOWING PAGE

A

SQUARE POINT LARGER BALL LOCK PUNCH

(P33 STANDARD – P34 ALTERNATE)



Stamping

10/30/96

P33 STANDARD	
NAAMS CODE NO.	D X L
P331380	13 X 80
P331680	16 X 80
P332080	20 X 80
P332580	25 X 80
P333280	32 X 80
P334080	40 X 80
P331390	13 X 90
P331690	16 X 90
P332090	20 X 90
P332590	25 X 90
P333290	32 X 90
P334090	40 X 90
P331300	13 X 100
P331600	16 X 100
P332000	20 X 100
P332500	25 X 100
P333200	32 X 100
P334000	40 X 100

P34 ALTERNATE	
NAAMS CODE NO.	D X L
P341380	13 X 80
P341680	16 X 80
P342080	20 X 80
P342580	25 X 80
P343280	32 X 80
P344080	40 X 80
P341390	13 X 90
P341690	16 X 90
P342090	20 X 90
P342590	25 X 90
P343290	32 X 90
P344090	40 X 90
P341300	13 X 100
P341600	16 X 100
P342000	20 X 100
P342500	25 X 100
P343200	32 X 100
P344000	40 X 100

RECTANGLE POINT LARGER BALL LOCK PUNCH

(P43 STANDARD – P44 ALTERNATE)

Stamping

04/24/14

(HEAVY DUTY)

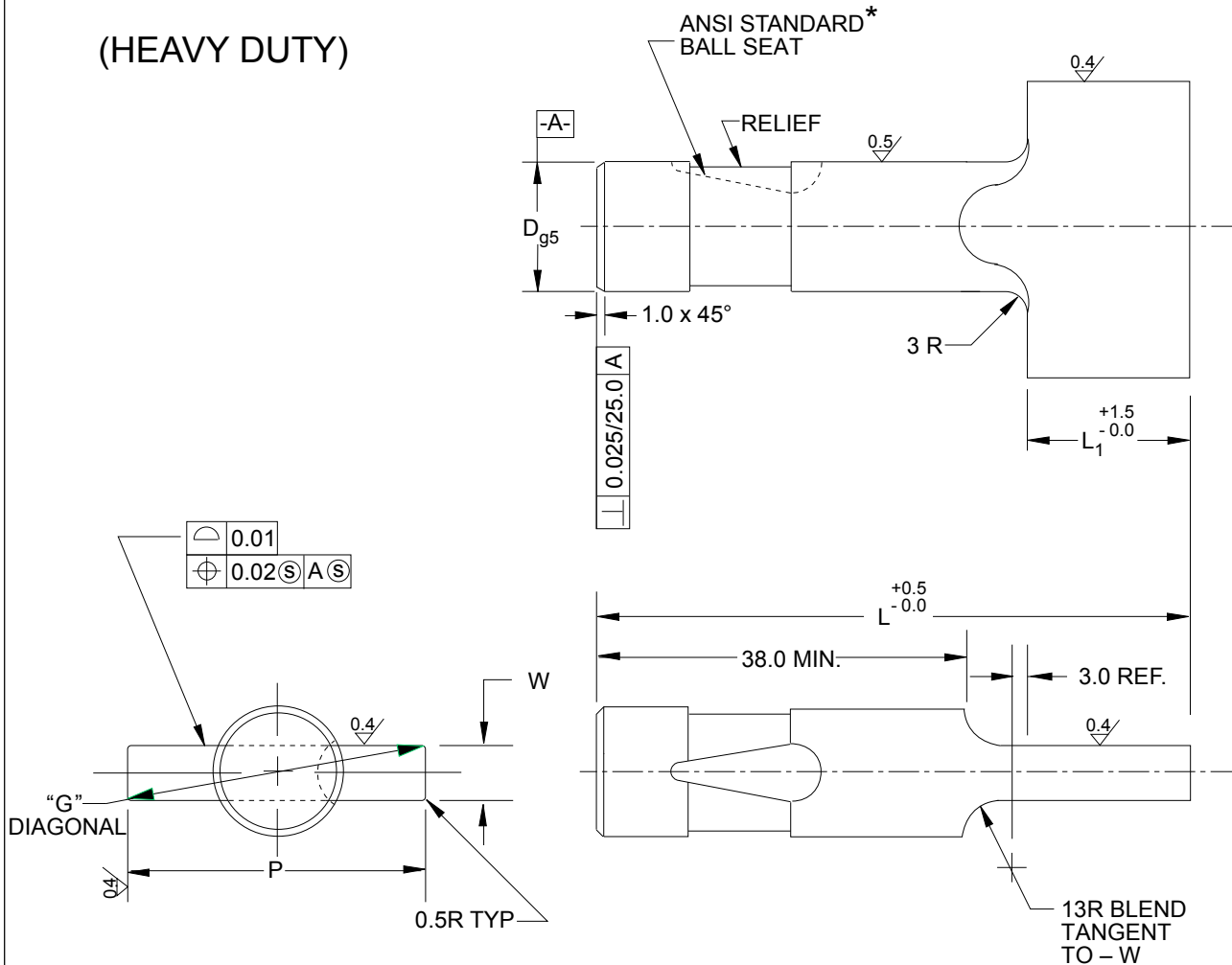

D NOMINAL SHANK Ø	PUNCH POINTS AVAILABLE 0.01 INCREMENTS		L OVERALL LENGTH				L1 POINT LENGTH		PUNCH RETAINER NAAMS CODE
	W MIN	G MAX	71	80	90	100	P43 STD.	P44 ALT	
10	3.0	25.0	X	X	X	X	16	30	P010010
13	5.0	32.0	X	X	X	X	19	30	P010013
16	6.0	38.0	X	X	X	X	19	30	P010016
20	8.0	40.0	X	X	X	X	19	30	P010020
25	10.0	47.0	X	X	X	X	19	30	P010025
32	11.5	63.0		X	X	X	19	30	P010032
40	14.0	63.0		X	X	X	19	30	P010040

$$G = 2 \sqrt{[(P/2-R)^2 + (W/2-R)^2 + R]}$$

NOTES & SPECIFICATIONS: $G_{MAX} = D - 0.2$

Material, AISI-M2.

Hardness, Rc 60-63. Triple temper.

Identification, etch the word "Metric" on each piece.

* Ball Seat must conform to ANSI Standard gages for locking location.

CODING ON FOLLOWING PAGE

RECTANGLE POINT LARGER BALL LOCK PUNCH

(P43 STANDARD – P44 ALTERNATE)

P43 STANDARD	
NAAMS CODE NO.	D X L
P431380	13 X 80
P431680	16 X 80
P432080	20 X 80
P432580	25 X 80
P433280	32 X 80
P434080	40 X 80
P431390	13 X 90
P431690	16 X 90
P432090	20 X 90
P432590	25 X 90
P433290	32 X 90
P434090	40 X 90
P431300	13 X 100
P431600	16 X 100
P432000	20 X 100
P432500	25 X 100
P433200	32 X 100
P434000	40 X 100

P44 ALTERNATE	
NAAMS CODE NO.	D X L
P441380	13 X 80
P441680	16 X 80
P442080	20 X 80
P442580	25 X 80
P443280	32 X 80
P444080	40 X 80
P441390	13 X 90
P441690	16 X 90
P442090	20 X 90
P442590	25 X 90
P443290	32 X 90
P444090	40 X 90
P441300	13 X 100
P441600	16 X 100
P442000	20 X 100
P442500	25 X 100
P443200	32 X 100
P444000	40 X 100

ROUND POINT LARGER BALL LOCK EJECTOR PUNCH

(P18 STANDARD – P19 ALTERNATE)

Stamping

03/13/97

(HEAVY DUTY)

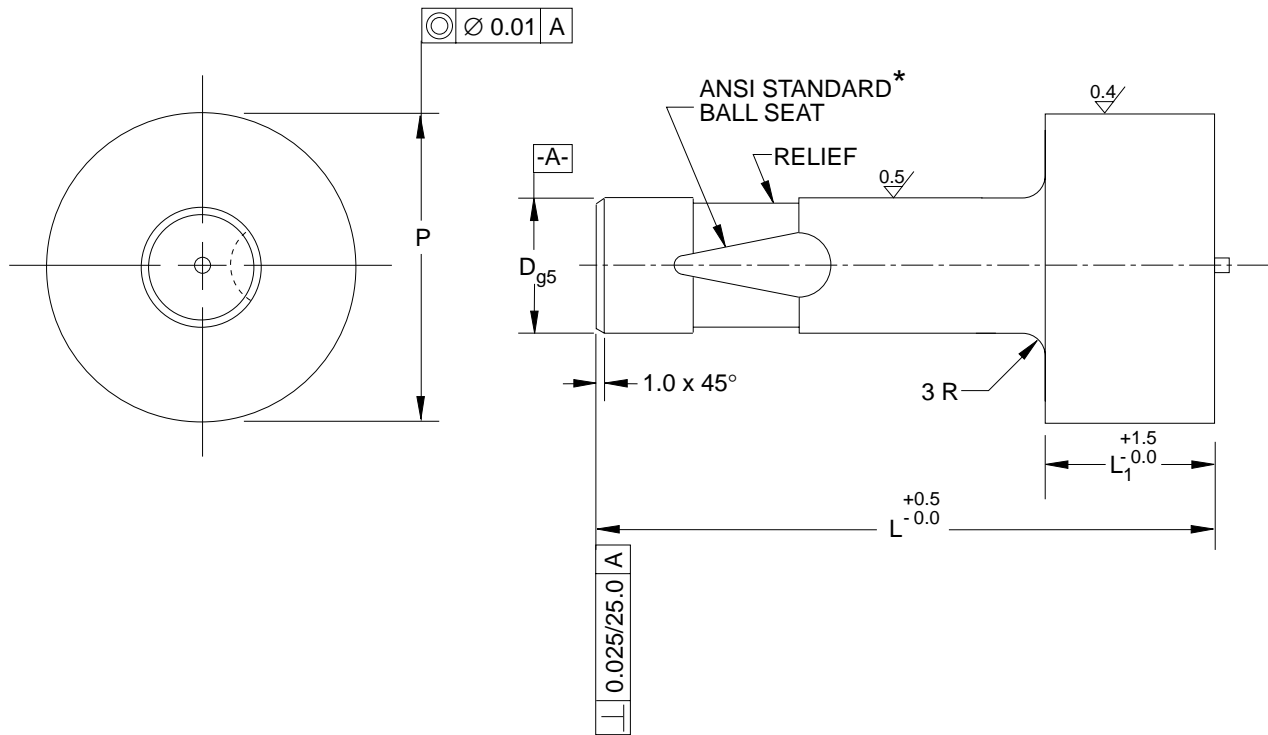

D NOMINAL SHANK Ø	P PUNCH POINTS AVAILABLE 0.01 INCREMENTS	L OVERALL LENGTH	L1 POINT LENGTH		PUNCH RETAINER NAAMS CODE
			P18 STD.	P19 ALT	
13	13.1 to 32.0	80	19	30	P010013
16	16.1 to 38.0		19	30	P010016
20	20.1 to 40.0		19	30	P010020
25	25.1 to 44.0	90	19	30	P010025
32	32.1 to 50.0	100	19	30	P010032
40	40.1 to 56.0		19	30	P010040

NOTES & SPECIFICATIONS:

- Material, AISI-M2.
- Hardness, Rc 60-63. Triple temper.
- Identification, etch the word "Metric" on each piece.
- * Ball Seat must conform to ANSI Standard gages for locking location.

CODING ON FOLLOWING PAGE

ROUND POINT LARGER BALL LOCK EJECTOR PUNCH

(P18 STANDARD – P19 ALTERNATE)



Stamping

10/30/96

P18 STANDARD	
NAAMS CODE NO.	D X L
P181380	13 X 80
P181680	16 X 80
P182080	20 X 80
P182580	25 X 80
P183280	32 X 80
P184080	40 X 80
P181390	13 X 90
P181690	16 X 90
P182090	20 X 90
P182590	25 X 90
P183290	32 X 90
P184090	40 X 90
P181300	13 X 100
P181600	16 X 100
P182000	20 X 100
P182500	25 X 100
P183200	32 X 100
P184000	40 X 100

P19 ALTERNATE	
NAAMS CODE NO.	D X L
P191380	13 X 80
P191680	16 X 80
P192080	20 X 80
P192580	25 X 80
P193280	32 X 80
P194080	40 X 80
P191390	13 X 90
P191690	16 X 90
P192090	20 X 90
P192590	25 X 90
P193290	32 X 90
P194090	40 X 90
P191300	13 X 100
P191600	16 X 100
P192000	20 X 100
P192500	25 X 100
P193200	32 X 100
P194000	40 X 100

OBLONG POINT LARGER BALL LOCK EJECTOR PUNCH

(P28 STANDARD – P29 ALTERNATE)

GLOBAL STANDARD COMPONENTS



Stamping

05/14/97

(HEAVY DUTY)

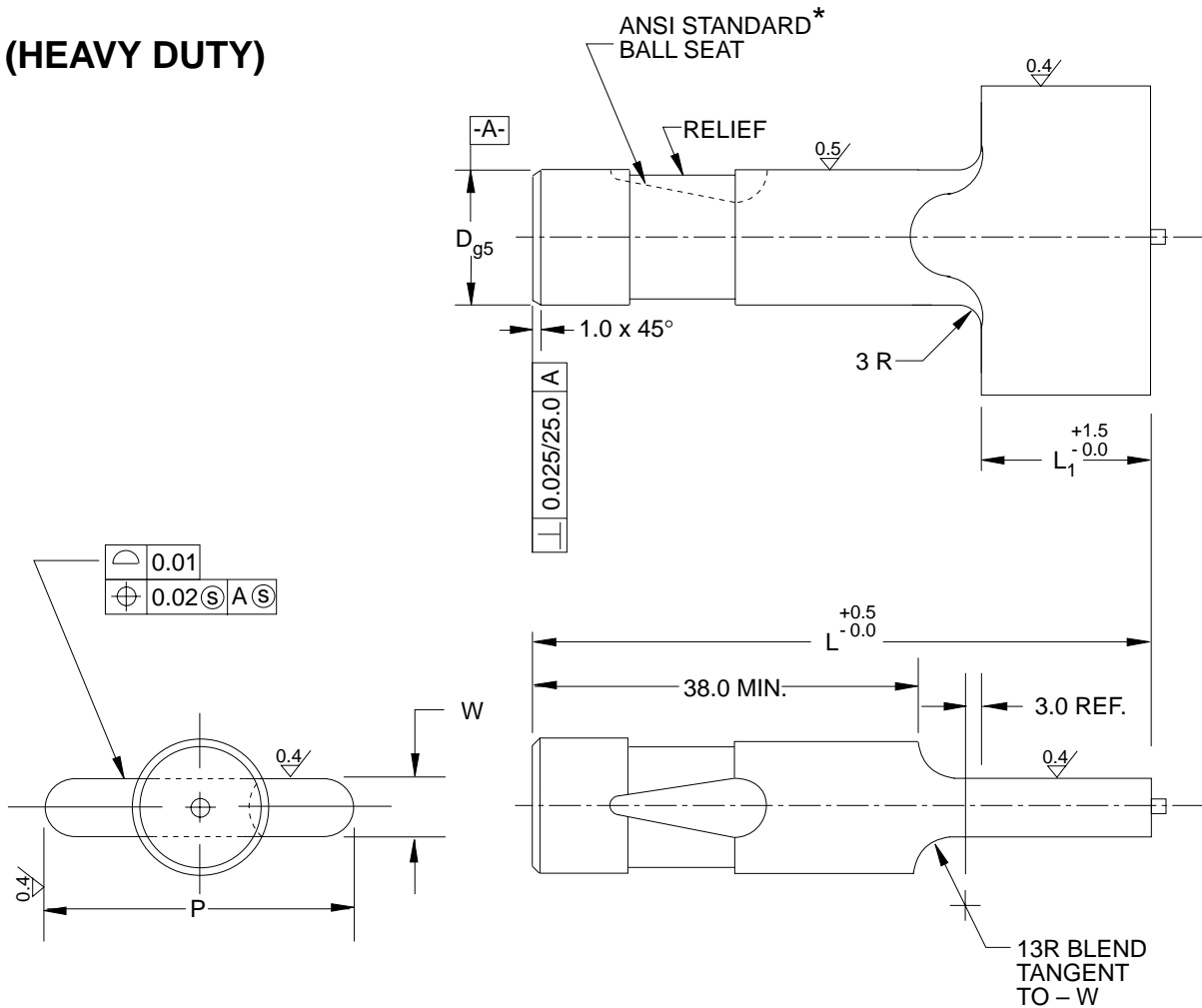

D NOMINAL SHANK Ø	PUNCH POINTS AVAILABLE 0.01 INCREMENTS		L OVERALL LENGTH	L1 POINT LENGTH		PUNCH RETAINER NAAMS CODE
	W	P		P28 STD.	P29 ALT	
13	5.0 to 31.9	13.1 to 32.0	80	19	30	P010013
16	6.0 to 37.9	16.1 to 38.0		19	30	P010016
20	8.0 to 39.9	20.1 to 40.0		19	30	P010020
25	10.0 to 43.9	25.1 to 44.0	90	19	30	P010025
32	11.5 to 49.9	32.1 to 50.0	100	19	30	P010032
40	14.0 to 55.9	40.1 to 56.0		19	30	P010040

NOTES & SPECIFICATIONS:

Material, AISI-M2.

Hardness, Rc 60-63. Triple temper.

Identification, etch the word "Metric" on each piece.

* Ball Seat must conform to ANSI Standard gages for locking location.

CODING ON FOLLOWING PAGE

OBLONG POINT LARGER BALL LOCK EJECTOR PUNCH

(P28 STANDARD – P29 ALTERNATE)

GLOBAL STANDARD COMPONENTS



Stamping

10/30/96

P28 STANDARD	
NAAMS CODE NO.	D X L
P281380	13 X 80
P281680	16 X 80
P282080	20 X 80
P282580	25 X 80
P283280	32 X 80
P284080	40 X 80
P281390	13 X 90
P281690	16 X 90
P282090	20 X 90
P282590	25 X 90
P283290	32 X 90
P284090	40 X 90
P281300	13 X 100
P281600	16 X 100
P282000	20 X 100
P282500	25 X 100
P283200	32 X 100
P284000	40 X 100

P29 ALTERNATE	
NAAMS CODE NO.	D X L
P291380	13 X 80
P291680	16 X 80
P292080	20 X 80
P292580	25 X 80
P293280	32 X 80
P294080	40 X 80
P291390	13 X 90
P291690	16 X 90
P292090	20 X 90
P292590	25 X 90
P293290	32 X 90
P294090	40 X 90
P291300	13 X 100
P291600	16 X 100
P292000	20 X 100
P292500	25 X 100
P293200	32 X 100
P294000	40 X 100

SQUARE POINT LARGER BALL LOCK EJECTOR PUNCH

GLOBAL STANDARD COMPONENTS



(P38 STANDARD – P39 ALTERNATE)

Stamping

05/14/97

(HEAVY DUTY)

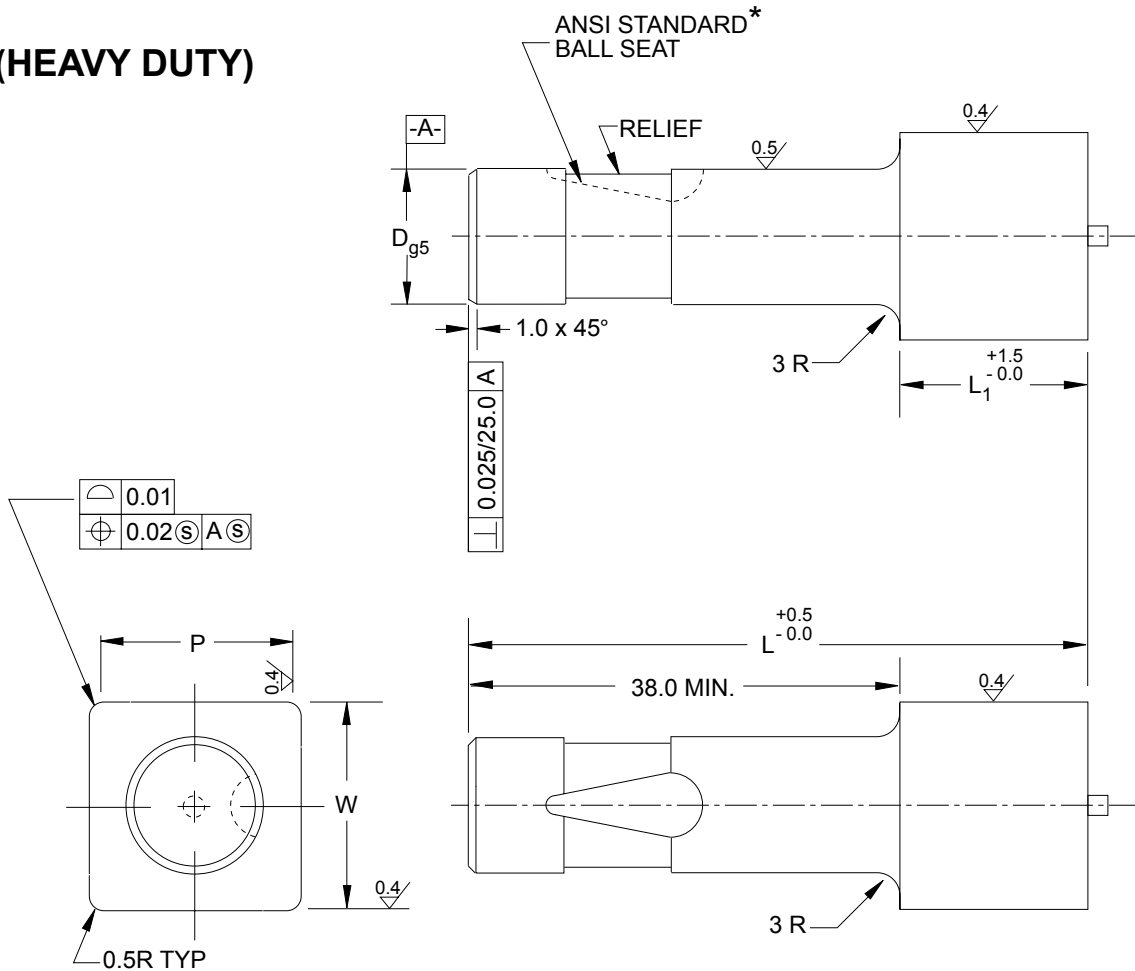

D NOMINAL SHANK Ø	P=W PUNCH POINTS AVAILABLE 0.01 INCREMENTS	L OVERALL LENGTH	L1 POINT LENGTH		PUNCH RETAINER NAAMS CODE	
			P38 STD.	P39 ALT		
13	9.6 to 22.8	80	19	30	P010013	
16	11.7 to 27.1		19	30	P010016	
20	14.5 to 28.5		19	30	P010020	
25	18.1 to 31.4		90	19	30	P010025
32	23.0 to 35.6		100	19	30	P010032
40	28.7 to 39.8			19	30	P010040

NOTES & SPECIFICATIONS:

Material, AISI-M2.

Hardness, Rc 60-63. Triple temper.

Identification, etch the word "Metric" on each piece.

* Ball Seat must conform to ANSI Standard gages for locking location.

CODING ON FOLLOWING PAGE

SQUARE POINT LARGER BALL LOCK EJECTOR PUNCH

(P38 STANDARD – P39 ALTERNATE)



Stamping

10/30/96

P38 STANDARD	
NAAMS CODE NO.	D X L
P381380	13 X 80
P381680	16 X 80
P382080	20 X 80
P382580	25 X 80
P383280	32 X 80
P384080	40 X 80
P381390	13 X 90
P381690	16 X 90
P382090	20 X 90
P382590	25 X 90
P383290	32 X 90
P384090	40 X 90
P381300	13 X 100
P381600	16 X 100
P382000	20 X 100
P382500	25 X 100
P383200	32 X 100
P384000	40 X 100

P39 ALTERNATE	
NAAMS CODE NO.	D X L
P391380	13 X 80
P391680	16 X 80
P392080	20 X 80
P392580	25 X 80
P393280	32 X 80
P394080	40 X 80
P391390	13 X 90
P391690	16 X 90
P392090	20 X 90
P392590	25 X 90
P393290	32 X 90
P394090	40 X 90
P391300	13 X 100
P391600	16 X 100
P392000	20 X 100
P392500	25 X 100
P393200	32 X 100
P394000	40 X 100

RECTANGLE POINT LARGER BALL LOCK EJECTOR PUNCH

(P48 STANDARD – P49 ALTERNATE)

Stamping

05/14/97

(HEAVY DUTY)

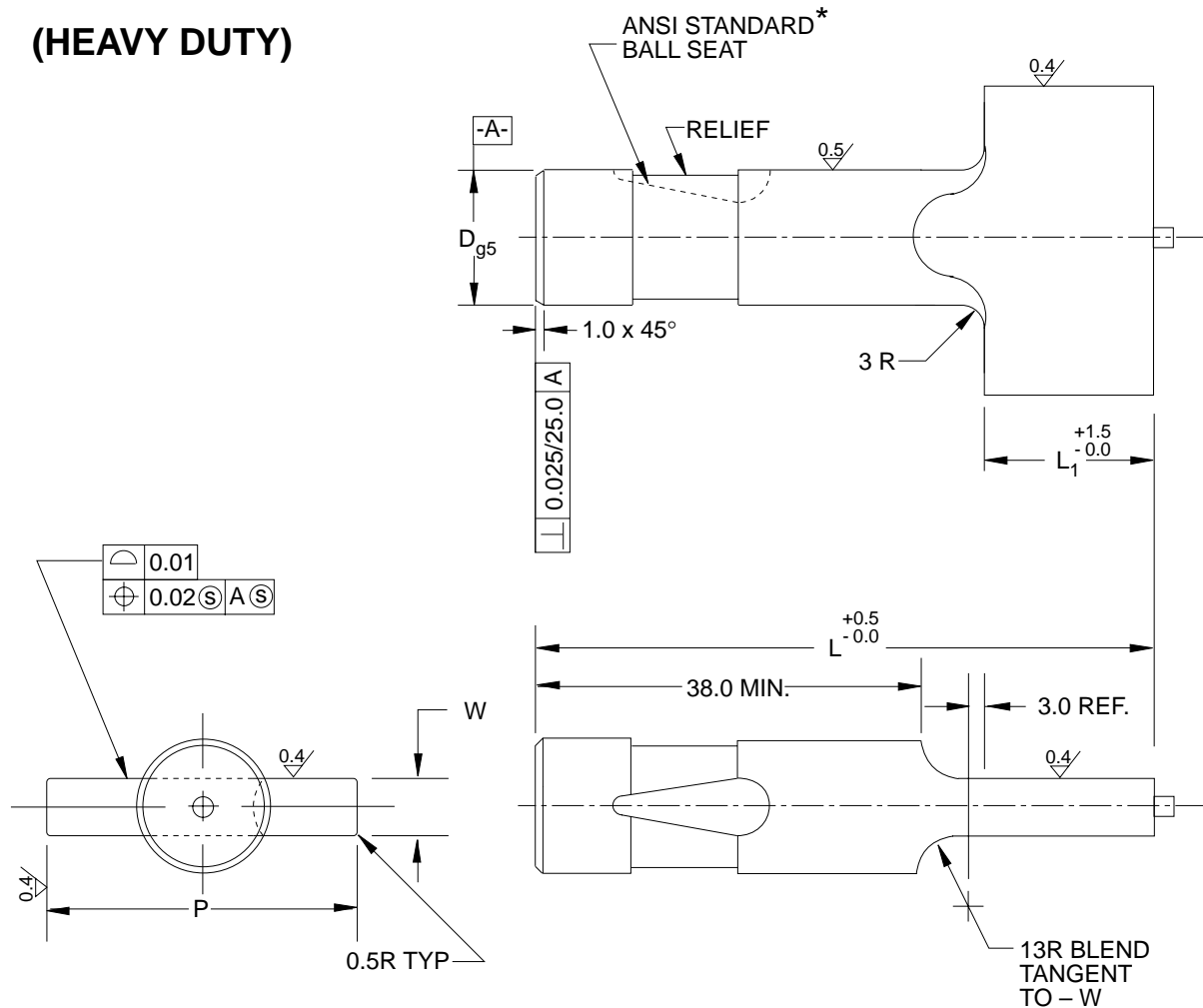

D NOMINAL SHANK Ø	PUNCH POINTS AVAILABLE 0.01 INCREMENTS		L OVERALL LENGTH	L1 POINT LENGTH		PUNCH RETAINER NAAMS CODE
	W	P		P48 STD.	P49 ALT	
13	5.0 to 14.0	12.4 to 29.0	80	19	30	P010013
16	6.0 to 15.0	15.2 to 35.2		19	30	P010016
20	8.0 to 17.0	18.7 to 36.5		19	30	P010020
25	10.0 to 19.0	23.3 to 40.0	90	19	30	P010025
32	11.5 to 20.5	30.2 to 45.9	100	19	30	P010032
40	14.0 to 23.0	37.8 to 51.3		19	30	P010040

NOTES & SPECIFICATIONS:

Material, AISI-M2.

Hardness, Rc 60-63. Triple temper.

Identification, etch the word "Metric" on each piece.

* Ball Seat must conform to ANSI Standard gages for locking location.

CODING ON FOLLOWING PAGE

RECTANGLE POINT LARGER BALL LOCK EJECTOR PUNCH

(P48 STANDARD – P49 ALTERNATE)



Stamping

10/30/96

P48 STANDARD	
NAAMS CODE NO.	D X L
P481380	13 X 80
P481680	16 X 80
P482080	20 X 80
P482580	25 X 80
P483280	32 X 80
P484080	40 X 80
P481390	13 X 90
P481690	16 X 90
P482090	20 X 90
P482590	25 X 90
P483290	32 X 90
P484090	40 X 90
P481300	13 X 100
P481600	16 X 100
P482000	20 X 100
P482500	25 X 100
P483200	32 X 100
P484000	40 X 100

P49 ALTERNATE	
NAAMS CODE NO.	D X L
P491380	13 X 80
P491680	16 X 80
P492080	20 X 80
P492580	25 X 80
P493280	32 X 80
P494080	40 X 80
P491390	13 X 90
P491690	16 X 90
P492090	20 X 90
P492590	25 X 90
P493290	32 X 90
P494090	40 X 90
P491300	13 X 100
P491600	16 X 100
P492000	20 X 100
P492500	25 X 100
P493200	32 X 100
P494000	40 X 100

HEADED URETHANE PUNCH STRIPPER (P05 SERIES)

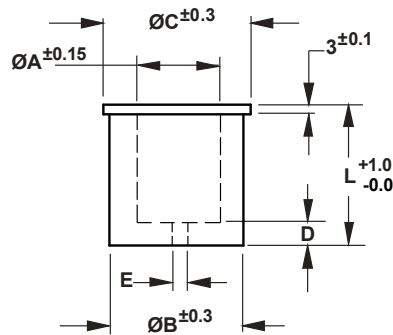

NAAMS CODE	PUNCH SHANK Ø	L +1.0/-0.0 STRIPPER LENGTH	DEFLECTIONS LOAD RATINGS IN NEWTONS			"A" PRESS FIT	B	C	D	"E" VENT HOLE
			3	6	9					
P051044	10	44	720	1400	①	9.75	18	21	6	1.6
P051054		54	690	1180	1510					
P051064		64	670	1060	1270					
P051074		74	650	1020	1220					
P051344	13	44	1300	2180	①	12.75	23	26	6	3.0
P051354		54	1180	2030	2470					
P051364		64	1020	1780	2160					
P051374		74	810	1510	2140					
P051644	16	44	1550	2660	①	15.75	28	31	6	3.0
P051654		54	1410	2400	3690					
P051664		64	1260	2280	3200					
P051674		74	1120	1870	2810					
P052044	20	44	2140	3680	①	19.75	33	36	7	3.0
P052054		54	2000	3390	4580					
P052064		64	1860	3210	4230					
P052074		74	1730	2940	3980					
P052544	25	44	2870	4950	①	24.75	40	43	7	3.0
P052554		54	2660	4550	6670					
P052564		64	2460	4110	5980					
P052574		74	2220	3800	5500					
P053244	32	44	4390	7560	①	31.70	50	55	7	3.0
P053254		54	4020	6920	10010					
P053264		64	3480	6060	8120					
P053274		74	3260	5660	7570					
P054044	40	44	5390	9830	①	39.70	60	65	8	3.0
P054054		54	4920	8650	12740					
P054064		64	4450	7950	11450					

① 44 mm LONG STRIPPERS SHOULD NOT BE COMPRESSED MORE THAN 6.5 mm - MORE COMPRESSION EXCEEDS RECOMMENDED MAXIMUM OF 15%

NOTES & SPECIFICATIONS:

MATERIAL: POLYURETHANE - HARDNESS 95 SHORE A

- Mark with NAAMS code and manufacturer's logo.
- Use with P06 retainer - See P-87
- Use 54 mm length stripper for 90 mm punches.
- Stripper overall lengths will result in a 3-4 mm extension beyond punch point end of 80,90,100 and 110 mm OAL punch lengths.
- Punch point is to be pierced in urethane stripper before assembly.
- Set length at final deflections of 3, 6 and 9 mm will be 1, 2 and 3 mm respectively.

Blank Page

A

**Data Removed.
Pages Left Blank For Future Use.**

COMPACT BALL LOCK PUNCH CHANGE RETAINER

INSTALLATION

GLOBAL STANDARD COMPONENTS



Stamping

10/20/10

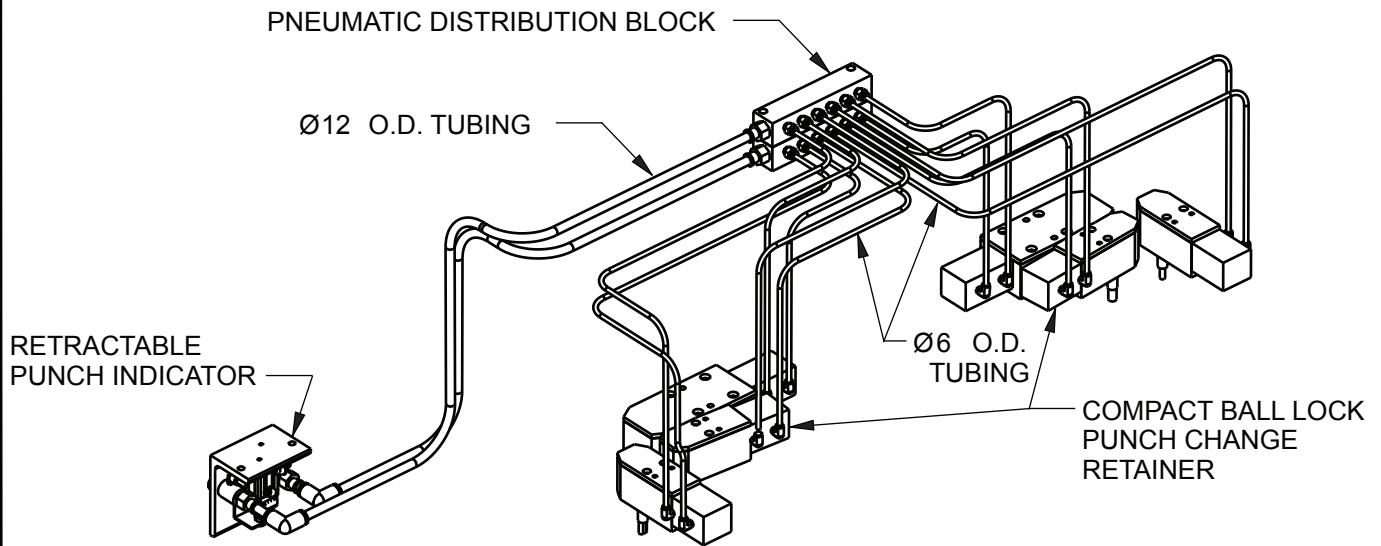

TYPICAL COMPACT BALL LOCK PUNCH CHANGE RETAINER SETUP

MOMENTARILY HOOK SHOP AIR HOSE TO THIS FITTING TO EXTEND PIERCE PUNCHES - REMOVE AIR HOSE BEFORE RUNNING PRESS.

ARROW WILL POINT TO EXTENDED PUNCH SYMBOL PUNCHES ARE NOW IN POSITION TO PIERCE HOLES.

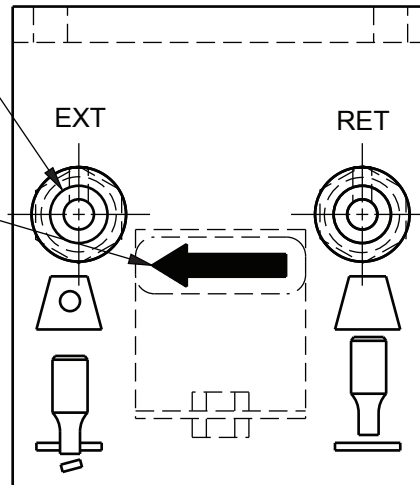

ISO G1/2" THREAD
INSTALL SHOP AIR FITTINGS

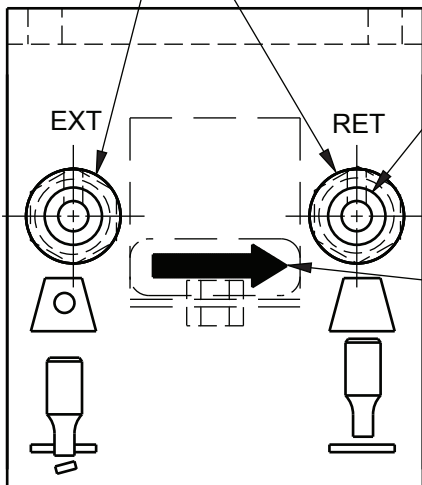

MOMENTARILY HOOK SHOP AIR HOSE TO THIS FITTING TO RETRACT PIERCE PUNCHES - REMOVE AIR HOSE BEFORE RUNNING PRESS.

ARROW WILL POINT TO RETRACTED PUNCH SYMBOL - PUNCHES ARE NOW IN POSITION TO NOT PIERCE HOLES.

COMPACT BALL LOCK PUNCH CHANGE RETAINER

(P98 SERIES)

GLOBAL STANDARD COMPONENTS



Stamping

10/20/10

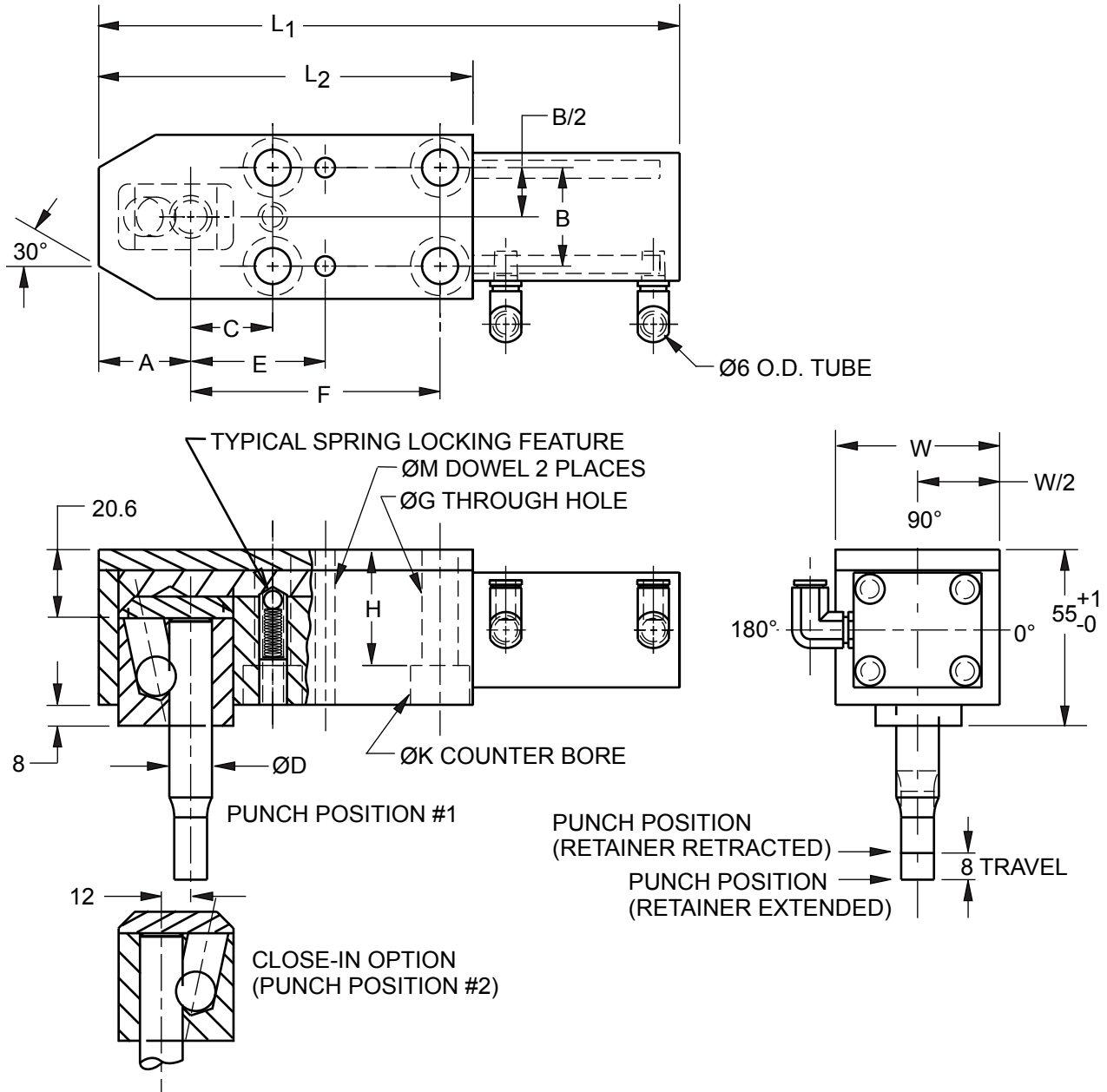

PUNCH SHANK ØD H6	MOUNTING SCREWS	DOWEL SIZE	W MAX	L ₁ MAX	L ₂ MAX	A MAX	B ±0.01	C ±0.13	E ±0.01	F ±0.13	G	H	K	ØM H7
10	M8 X 60	6 X 30	46	161	100	28	30	21	37	-	9	38	15	6.0
13	M10 X 60	6 X 30	50	173	100	28	30	25	41	-	11	36	18	6.0
16	M10 X 60	6 X 30	50	182	114	31	30	25	41	-	11	36	18	6.0
20	M10 X 60	6 X 30	58	192	114	33	38	29	45	-	11	36	18	6.0
25	M10 X 60	6 X 30	58	207	124	35	38	29	45	-	11	36	18	6.0
32	M12 X 60	8 X 30	80	260	156	44	56	38	60	100	13.5	34	20	8.0
40	M12 X 60	8 X 30	80	264	156	44	56	38	60	100	13.5	34	20	8.0

CODING ON FOLLOWING PAGE

COMPACT BALL LOCK PUNCH CHANGE RETAINER

(P98 SERIES)

GLOBAL STANDARD COMPONENTS

NAAMS



Stamping

10/20/10

Complete NAAMS Code	Punch Shank \bar{y} D	Punch Position "#1"	Punch Position "#2"	Straight Air Fittings (Option #1)	90 Degree Air Fittings (Option #2)
P981011	10	X		X	
P981012	10	X			X
P981021	10		X	X	
P981022	10		X		X
P981311	13	X		X	
P981312	13	X			X
P981321	13		X	X	
P981322	13		X		X
P981611	16	X		X	
P981612	16	X			X
P981621	16		X	X	
P981622	16		X		X
P982011	20	X		X	
P982012	20	X			X
P982021	20		X	X	
P982022	20		X		X
P982511	25	X		X	
P982512	25	X			X
P982521	25		X	X	
P982522	25		X		X
P983211	32	X		X	
P983212	32	X			X
P983221	32		X	X	
P983222	32		X		X
P984011	40	X		X	
P984012	40	X			X
P984021	40		X	X	
P984022	40		X		X

BALL LOCK PUNCH CHANGE INDICATOR

(P980006)

GLOBAL STANDARD COMPONENTS



Stamping

10/20/10

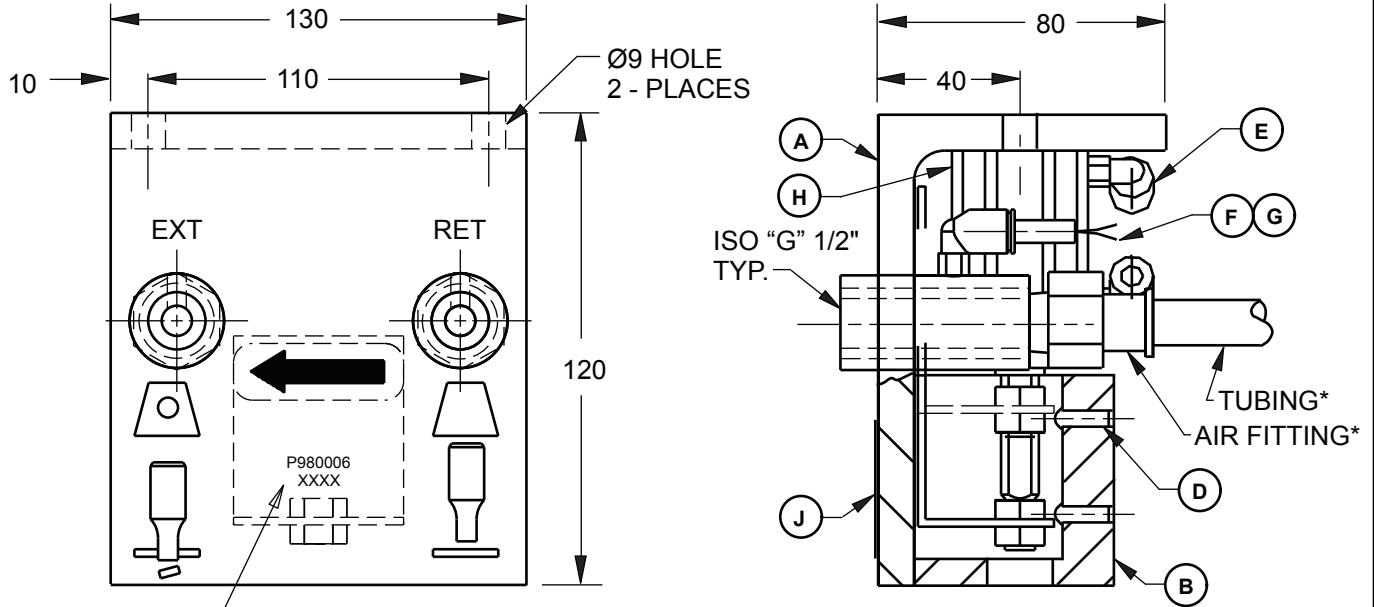

Mark with NAAMS Code and Manufacturer's Logo in 6 mm High Lettering.

*ORDER SEPARATELY

RETRACTABLE PUNCH INDICATOR

NAAMS CODE
P980006

DET.	QUAN.	DESCRIPTION
A	1	MAIN BODY - ALUMINUM ANGLE 6061-T6 MEDIUM BLUE ANODIZED
B	1	FLAG COVER - ALUMINUM 6061-T6 MEDIUM BLUE ANODIZED
C	1	INDICATOR FLAG - ALUMINUM ANGLE 6061-T6
D	2	BALL PLUNGER #56422
E	4	AIR FITTINGS SMC - KQ2L06-M5
F	1	Ø6 POLYURETHANE TUBING - RED
G	1	Ø6 POLYURETHANE TUBING - GREEN
H	1	AIR CYLINDER SMC - CQ2KB20 - 30DM
J	1	DECAL (AS SHOWN)

BALL LOCK PUNCH CHANGE INDICATOR

(P980006)

GLOBAL STANDARD COMPONENTS



Stamping

10/20/10

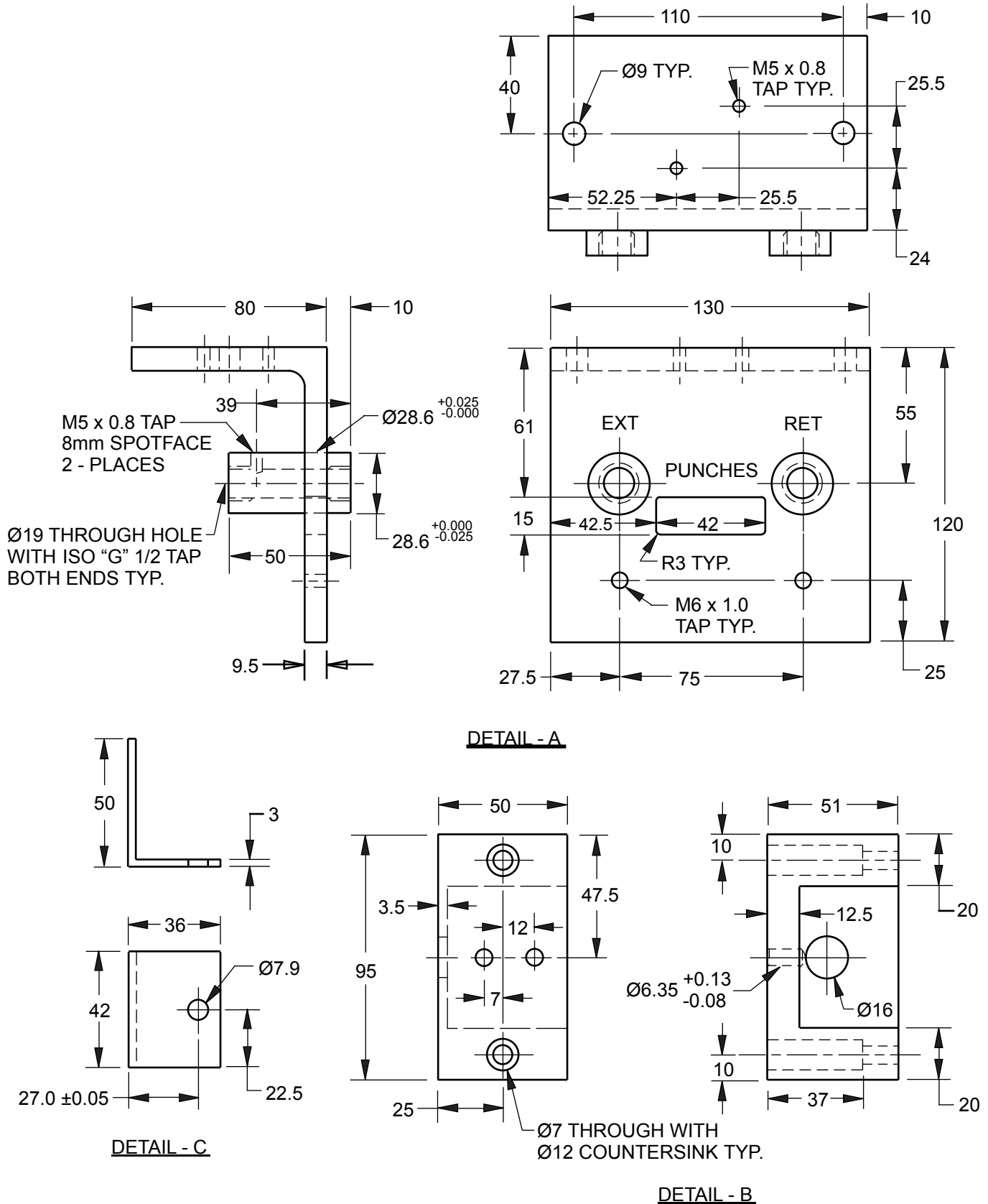

PNEUMATIC DISTRIBUTION BLOCK

(P980007)

GLOBAL STANDARD COMPONENTS



Stamping

10/20/10

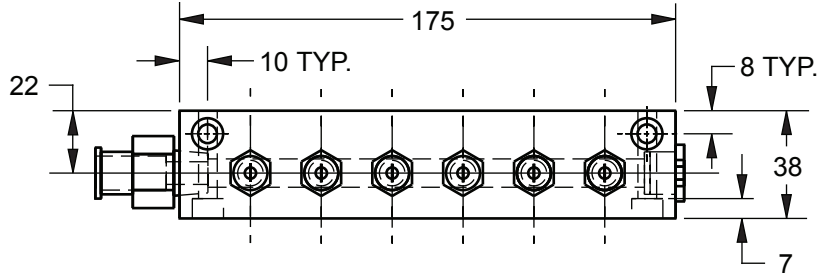

PLUG UNUSED HOLES WITH
ISO "G" 1/4" PORT PLUG
(NOT SUPPLIED - ORDER AS NEEDED)

1/4" ISO "G" THREAD (6 - PLACES)

ISO "R" 1/4" MALE CONNECTOR FOR Ø6 mm O.D. TUBE
(NOT SUPPLIED - ORDER AS NEEDED)

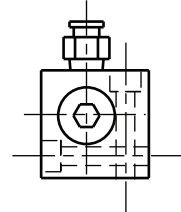
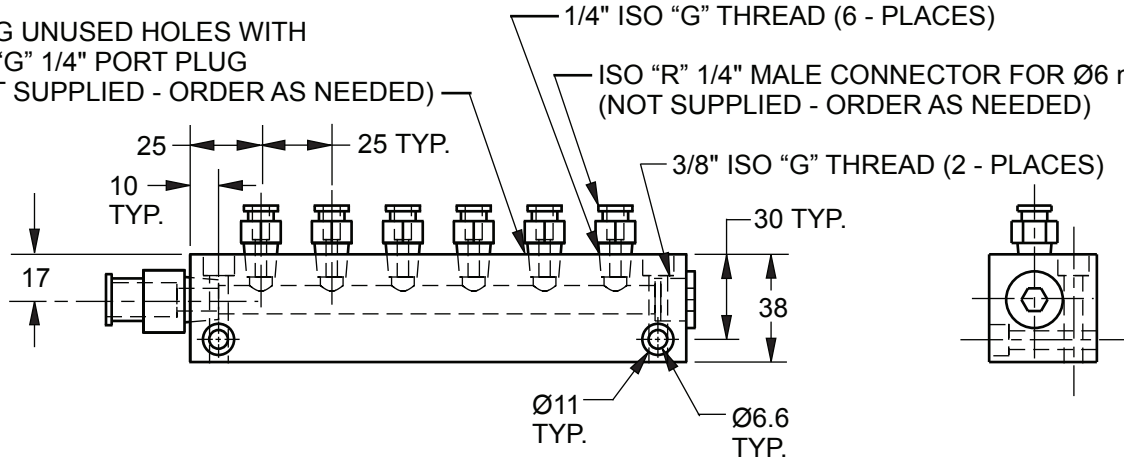

PNEUMATIC DISTRIBUTION BLOCK

NOTES & SPECIFICATIONS

MATERIAL: ANSI 6061-T6
FINISH: MEDIUM BLUE ANODIZED
BREAK ALL EDGES

SNAP-IN RETAINER

(P06 SERIES)

Stamping

03/09/22

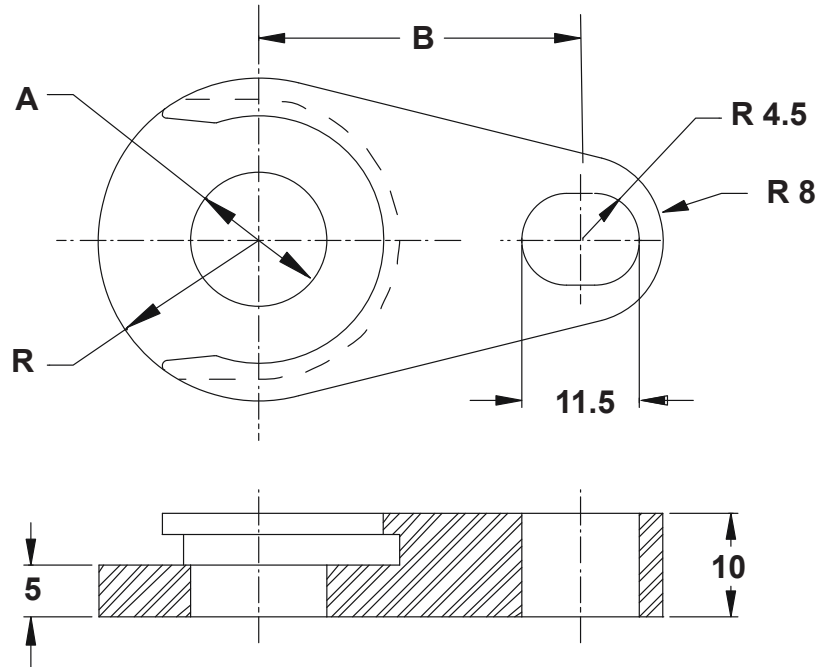

NAAMS CODE	A	B	R
P060010	10	28.0	13
P060013	13	31.0	15.5
P060016	16	32.9	18
P060020	20	34.8	20.5
P060025	25	39.8	24
P060032	32	41.3	31
P060040	40	45.0	36

NOTES & SPECIFICATIONS:

MATERIAL: ISO 683/18 - C20

- Break all edges.
- Mark with NAAMS code and manufacturer's logo.
- Use with P05 urethane punch stripper - See P-79

SPECIAL URETHANE PUNCH STRIPPER WITH RADUS CORNERS

(P99 SERIES)

GUIDELINES FOR USING SPECIAL URETHANE PUNCH STRIPPERS

- USE SPECIAL URETHANE PUNCH STRIPPERS FOR PIERCING HOLES IN INNER AND OUTER
DO NOT USE ON CLASS ONE SURFACES.
- FOR ORDERING INFORMATION SEE PAGE P-89.
- THE PIERCE ANGLE TO THE PANEL SURFACE MUST NOT EXCEED 5°.
- THE PUNCH POINT CAN NOT BE LARGER THAN PUNCH SHANK DIAMETER.
- DO NOT EXCEED 15% MAXIMUM DEFLECTION ON THE URETHANE.
- PUNCH STRIPPERS CAN EXTEND 3 - 4 mm BEYOND PUNCH POINT, SEE PAGE P-89 .
- **DO NOT CUT OR SAND THE URETHANE PUNCH STRIPPER** TO PROVIDE WORKING CLEARANCE.
- BREAKING THE OUTER SKIN OF THE URETHANE GREATLY REDUCES PRODUCTION LIFE.

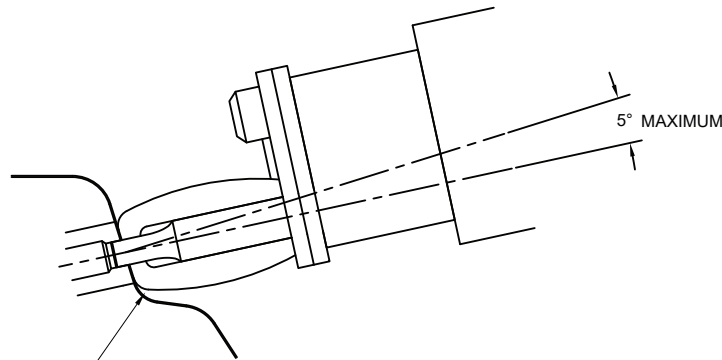

RADIUS SHOWN MOLDED IN THE URETHANE TO CLEAR PANEL RADIUS.
WITHOUT THE MOLDED RADIUS, THE URETHANE STRIPPER WOULD BE
STUFFED INTO THE RADIUS. THAT CAUSES SPLITS IN THE STRIPPER,
LEADING TO FAILURE.

SPECIAL URETHANE PUNCH STRIPPER WITH RADUS CORNERS

(P99 SERIES)

SPECIAL URETHANE PUNCH STRIPPER
FOR COMMON URETHANE PUNCH STRIPPERS SEE P-7 & P-8 and P-79 & P-87.
FOR THE APPLICATION PAGE SEE P-88

MATERIAL SPECIFICATIONS:

1. DUROMETER 95 ±2 SHORE A
COMPRESSIVE MODULES =
137.9 BAR @ SHAPE FACTOR =1
2. MAXIMUM DEFLECTION 15%
3. MAXIMUM PERMANENT
COMPRESSION SET 5%.

CHEMISTRY

TDI (PTMEG / MOCA COMPOUND)
PTMEG = POLYTETRAMETHYLENE
ETHER GLYCOL
MOCA = 4.4 METHYLENE-BIS
2 - CHOLOROANILINE
OR EQUIVALENT CHEMISTRY

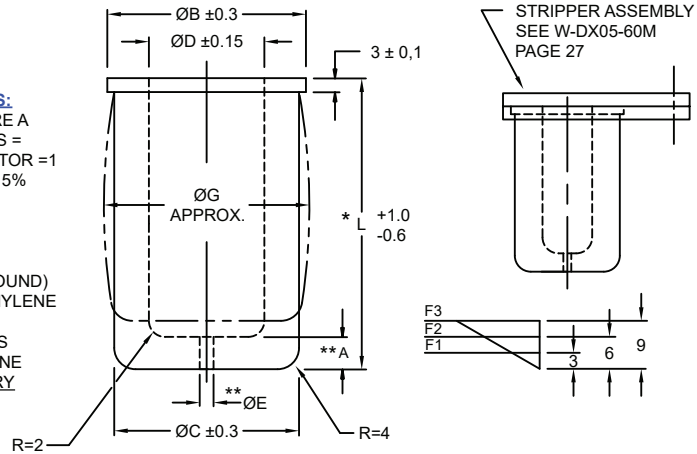

- * STRIPPER OVERALL LENGTHS WILL RESULT IN A 3 TO 4 mm EXTENSION BEYOND PUNCH POINT ENDS OF 100 mm OVER ALL PUNCH LENGTHS.
- ** PUNCH POINT SHAPE IS TO BE PIERCED IN URETHANE STRIPPER BEFORE ASSEMBLY.

- URETHANE PUNCH STRIPPER ASSEMBLIES CONSIST OF (1) URETHANE PUNCH STRIPPER (SEE THIS PAGE) AND (1) RETAINER PLATE ASSEMBLY (SEE P-7).
- FOR APPLICATION - SEE P-88.
- SPECIAL SHAPED URETHANE STRIPPERS ARE FOR 10 DIA. AND 13 DIA. PUNCH SHANKS ONLY.

NAAMS ASSEMBLY NUMBER	NAAMS PART NUMBER		PUNCH SHANK	** A	ØB	ØC	ØD	E	* L	F1 (N)			F3 (N)	ØG
	URETHANE STRIPPER	RETAINER PLATE								3mm	6mm	9mm		
P99301064-A	P99301064	P992710	Ø10	6	21.3	18.5	9.75	1.6	64	674	1121	1392	20.3	
P99301364-A	P99301364	P992713	Ø13	6	26.3	23.5	12.75	3.0	64	979	1775	2404	25.2	