

SHIMS AND SPACERS COMPONENTS INDEX

PAGE	DATE	NAAMS CODE	DESCRIPTION
J-1	03/19/21		Shims and Spacers Components Index
J-1.1	12/02/19	ASH1, ASH102 –ASH120	Metric Fitting Shims 1-Slot
J-2	12/02/19	ASH3, ASH302 –ASH320	Metric Fitting Shims 3-Slot
J-3	12/02/19	ASH4, ASH402 –ASH420	Metric Fitting Shims 4-Slot
J-4	02/04/20	ASP330–ASP370	Metric Fitting Spacers 3-Hole
J-5	02/04/20	ASP430–ASP470	Metric Fitting Spacers 4-Hole
J-6	02/04/20	ASP630–ASP670	Metric Fitting Spacers 6-Hole
J-7	02/04/20	ASP330S–ASP370S	Metric Fitting Spacers Short Slot (Small)
J-8	06/28/00	Discontinued	Metric Fitting Spacers Long Slot (Small)
J-9	02/04/20	ASP630S–ASP670S	Metric Fitting Spacers 2-Slot (Small)
J-10	02/04/20	ACS330S–ACS370S	Construction Spacer 3-Slot
J-11	02/04/20	ACS630–ACS670	Spacer for 60 x 60 and 70 x 70 Mounting
J-12	12/02/19	ASH6, ASH602 –ASH620	Metric Fitting Shims 2-Slot
J-13	12/02/19	ACH6, ACH602 –ACH620	Construction Shims 2-Slot
J-14	02/04/20	ASP530–ASP570	Metric Fitting Spacers 5-Hole
J-15	12/02/19	ASH5, ASH502 –ASH520	Metric Fitting Shims 5-Slot
J-16	12/02/19	ASH102N–ASH120N	Metric Fitting Shims 1-Slot (20 mm)
J-17	12/02/19	ASH302N–ASH320N	Metric Fitting Shims 3-Slot (20 mm)
J-18	12/02/19	ASH402N–ASH420N	Metric Fitting Shims 4-Slot (20 mm)
J-19	02/04/20	ASP430S–ASP470S	Metric Fitting Spacers For 3-Hole (20 mm)*
J-20	02/04/20	ASP430N–ASP470N	Metric Fitting Spacers 4-Hole (20 mm)
J-21	02/04/20	ASP630N–ASP670N	Metric Fitting Spacers 6-Hole (20 mm)
J-22	02/04/20	ASP230–ASP270	Metric Fitting Spacers 2-Hole
J-23	02/04/20	ASP730–ASP770	Spacer for Shock Bracket 4-Hole
J-24	03/19/21	ASP830–ASP870	Metric Fitting Spacer 4-Hole (16mm)

METRIC FITTING SHIMS 1 - SLOT

GLOBAL STANDARD COMPONENTS



Assembly

12/02/19

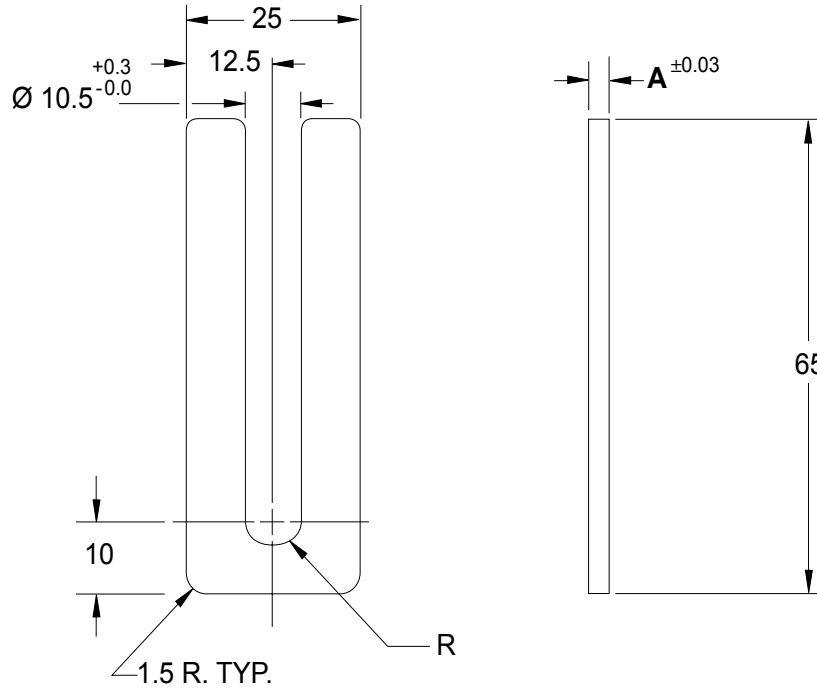

METRIC DIMENSIONAL TOLERANCES
UNLESS OTHERWISE SPECIFIED:

0 PLACE ± 0.5

1 PLACE ± 0.3

MATERIAL: S.A.E. 1010 CRS FULL HARD

SEE PAGE B-1.1 FOR GLOBAL MATERIALS CHART

SHIM PACK ASH1	
QTY.	NAAMS CODE
2	ASH102
3	ASH105
1	ASH110
1	ASH120

NAAMS CODE	A	SURFACE
ASH102	0.25	NONE
ASH105	0.50	YELLOW OR GOLD*
ASH110	1.00	BLACK OXIDE
ASH120	2.00	NONE

* = RoHS COMPLIANT TRIVALENT CHROMATE

C

A

D

B

E

METRIC FITTING SHIMS 3-SLOT

GLOBAL STANDARD COMPONENTS



Assembly

12/02/19

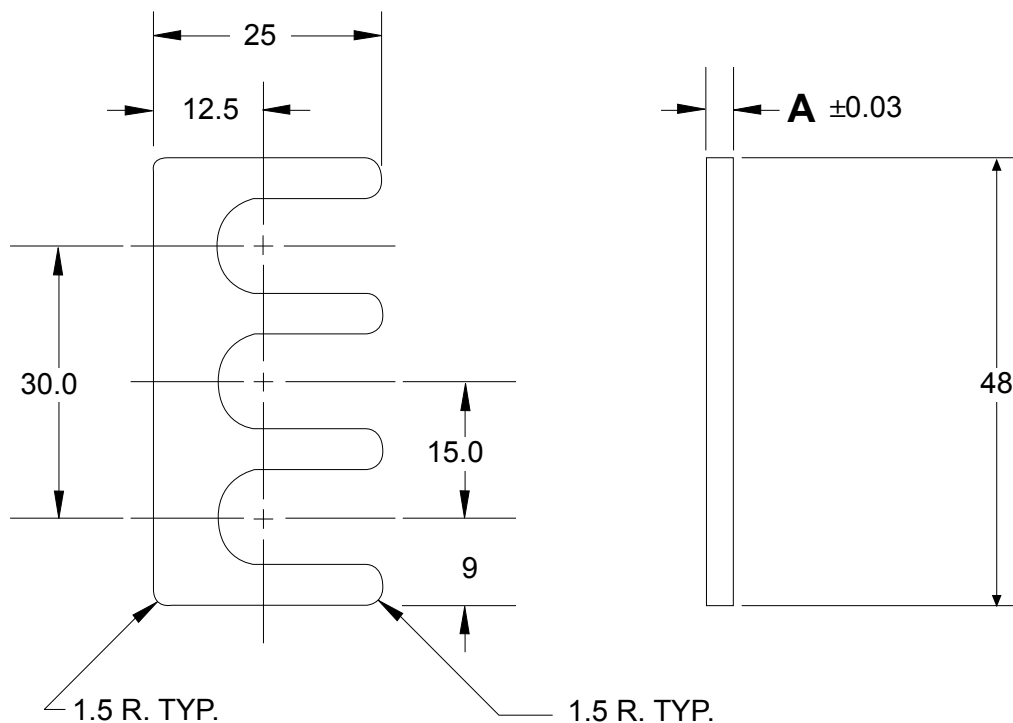

NOTE:

- 1.) ALL SLOTS TO BE 10.5 ± 0.20
- 2.) ROUNDED ENDS OF ALL SLOTS TO BE TRUE RADIUS 1/2 OF WIDTH.
- 3.) ALL SLOT LOCATING DIMENSIONS TO BE ± 0.25
- 4.) MAT'L COLD ROLLED STRIP STEEL S.A.E. 1010 FULL HARD

METRIC DIMENSIONAL TOLERANCES

UNLESS OTHERWISE SPECIFIED:

0 PLACE: ± 0.5

1 PLACE: ± 0.3

SEE PAGE B-1.1 FOR GLOBAL MATERIALS CHART

SHIM PACK ASH3	
QTY.	NAAMS CODE
2	ASH302
3	ASH305
1	ASH310
1	ASH320

NAAMS CODE	A	SURFACE
ASH302	0.25	NONE
ASH305	0.50	YELLOW OR GOLD*
ASH310	1.00	BLACK OXIDE
ASH320	2.00	NONE

* = RoHS COMPLIANT TRIVALENT CHROMATE

METRIC FITTING SHIMS 4-SLOT

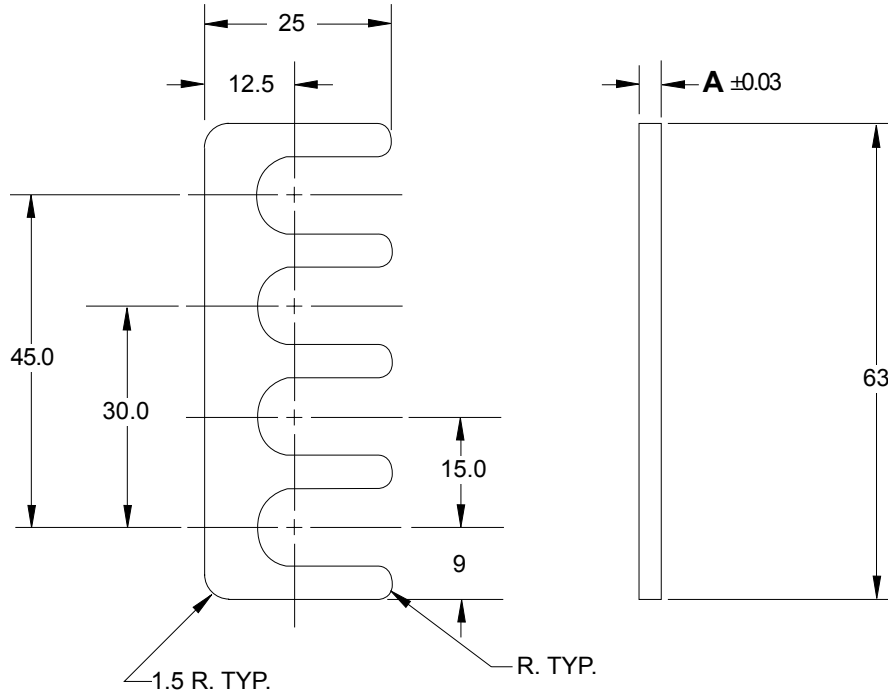

NOTE:

- 1.) ALL SLOTS TO BE 10.5 ± 0.20
- 2.) ROUNDED ENDS OF ALL SLOTS TO BE TRUE RADIUS 1/2 OF WIDTH.
- 3.) ALL SLOT LOCATING DIMENSIONS TO BE ± 0.25
- 4.) MAT'L COLD ROLLED STRIP STEEL S.A.E. 1010 FULL HARD

METRIC DIMENSIONAL TOLERANCES

UNLESS OTHERWISE SPECIFIED:

0 PLACE: ± 0.5

1 PLACE: ± 0.3

SEE PAGE B-1.1 FOR GLOBAL MATERIALS CHART

SHIM PACK ASH4	
QTY.	NAAMS CODE
2	ASH402
3	ASH405
1	ASH410
1	ASH420

NAAMS CODE	A	SURFACE
ASH402	0.25	NONE
ASH405	0.50	YELLOW OR GOLD*
ASH410	1.00	BLACK OXIDE
ASH420	2.00	NONE

* = RoHS COMPLIANT TRIVALENT CHROMATE

METRIC FITTING SPACERS 3-HOLE

GLOBAL STANDARD COMPONENTS



Assembly

02/04/20

NOTE:

- 1.) ETCH DIM A ON EDGE OF SPACER
- 2.) ALL DIMENSIONS ARE METRIC
- 3.) BLACK OXIDE FINISH
- 4.) SURFACES TO BE FLAT AND PARALLEL TO WITHIN 0.015 mm T.I.R.
- 5.) METRIC TOLERANCES: UNLESS OTHERWISE SPECIFIED:

- 1 PLACE ± 0.3 mm
- 2 PLACE ± 0.03 mm

MATERIAL: S.A.E. 1020 HRS

SEE PAGE B-1.1 FOR GLOBAL MATERIALS CHART

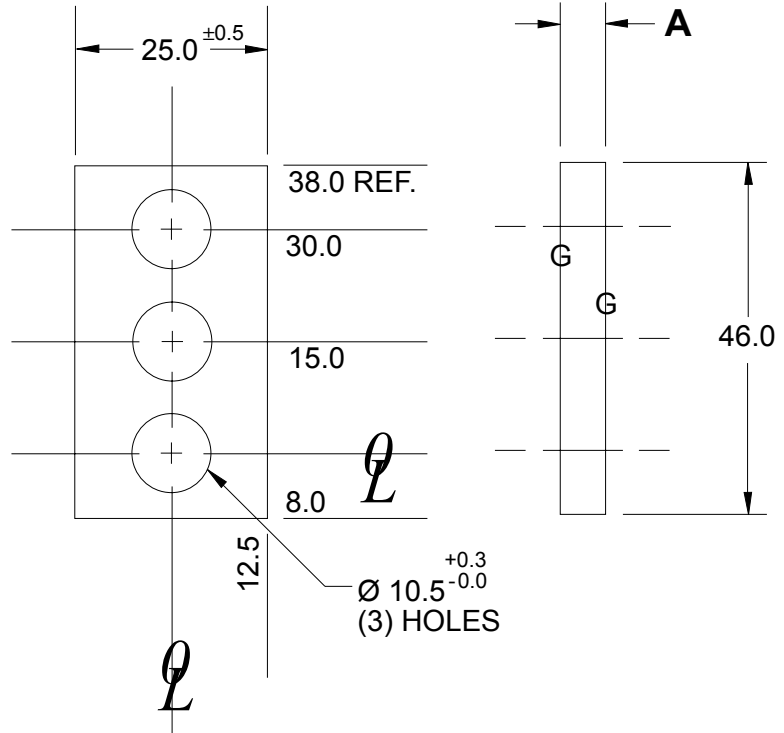

C

B

A

NAAMS CODE	A
ASP330	3.00
ASP332	3.20
ASP334	3.40
ASP336	3.60
ASP338	3.80
ASP340	4.00
ASP342	4.20
ASP344	4.40
ASP346	4.60
ASP348	4.80
ASP350	5.00
ASP352	5.20
ASP354	5.40
ASP356	5.60
ASP358	5.80
ASP360	6.00
ASP362	6.20
ASP364	6.40
ASP366	6.60
ASP368	6.80
ASP370	7.00

METRIC FITTING SPACERS 4-HOLE

GLOBAL STANDARD COMPONENTS



Assembly

02/04/20

NOTE:

- 1.) ETCH DIM A ON EDGE OF SPACER
- 2.) ALL DIMENSIONS ARE METRIC
- 3.) BLACK OXIDE FINISH
- 4.) SURFACES TO BE FLAT AND PARALLEL TO WITHIN 0.015 mm T.I.R.
- 5.) METRIC TOLERANCES: UNLESS OTHERWISE SPECIFIED:

- 1 PLACE ± 0.3 mm
- 2 PLACE ± 0.03 mm

MATERIAL: S.A.E. 1020 HRS

SEE PAGE B-1.1 FOR GLOBAL MATERIALS CHART

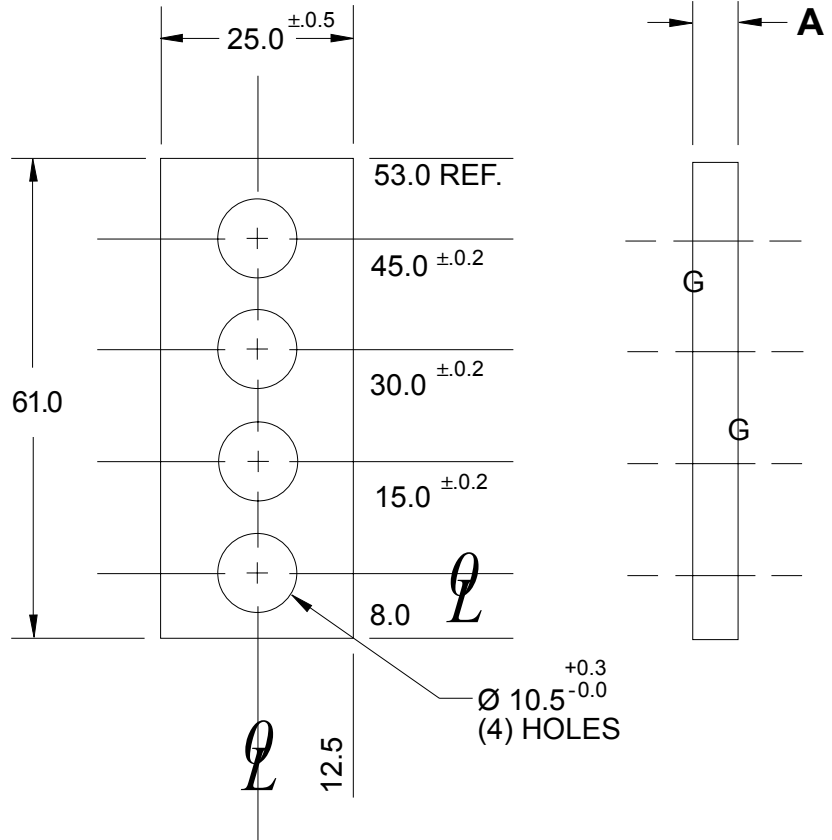

NAAMS CODE	A
ASP430	3.00
ASP432	3.20
ASP434	3.40
ASP436	3.60
ASP438	3.80
ASP440	4.00
ASP442	4.20
ASP444	4.40
ASP446	4.60
ASP448	4.80
ASP450	5.00
ASP452	5.20
ASP454	5.40
ASP456	5.60
ASP458	5.80
ASP460	6.00
ASP462	6.20
ASP464	6.40
ASP466	6.60
ASP468	6.80
ASP470	7.00

METRIC FITTING SPACERS 6-HOLE

GLOBAL STANDARD COMPONENTS



Assembly

02/04/20

NOTE:

- 1.) ETCH DIM A ON EDGE OF SPACER
- 2.) ALL DIMENSIONS ARE METRIC
- 3.) BLACK OXIDE FINISH
- 4.) SURFACES TO BE FLAT AND PARALLEL TO WITHIN 0.015 T.I.R.
- 5.) METRIC TOLERANCES:
UNLESS OTHERWISE SPECIFIED:
1 PLACE ± 0.3
2 PLACE ± 0.03

MATERIAL: S.A.E. 1020 HRS

SEE PAGE B-1.1 FOR GLOBAL MATERIALS CHART

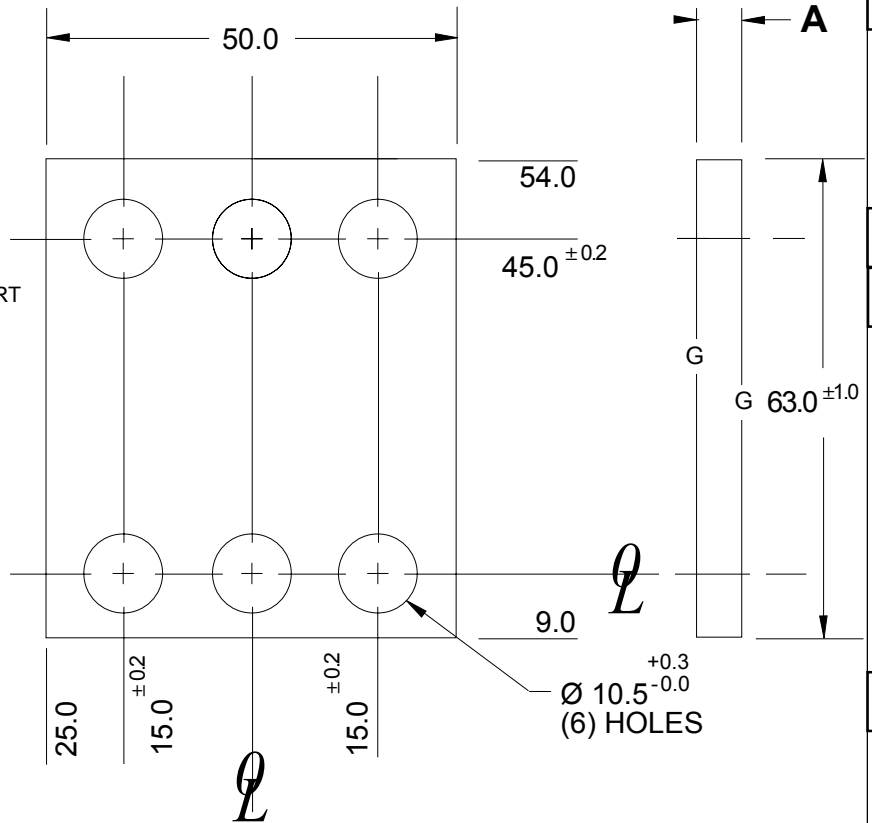

NAAMS CODE	A
ASP630	3.00
ASP632	3.20
ASP634	3.40
ASP636	3.60
ASP638	3.80
ASP640	4.00
ASP642	4.20
ASP644	4.40
ASP646	4.60
ASP648	4.80
ASP650	5.00
ASP652	5.20
ASP654	5.40
ASP656	5.60
ASP658	5.80
ASP660	6.00
ASP662	6.20
ASP664	6.40
ASP666	6.60
ASP668	6.80
ASP670	7.00

METRIC FITTING SPACERS SHORT SLOT (SMALL)

GLOBAL STANDARD COMPONENTS



Assembly

02/04/20

NOTE:

- 1.) ETCH DIM A ON EDGE OF SPACER
- 2.) ALL DIMENSIONS ARE METRIC
- 3.) BLACK OXIDE FINISH
- 4.) SURFACES TO BE FLAT AND PARALLEL TO WITHIN 0.015 mm T.I.R.
- 5.) METRIC TOLERANCES: UNLESS OTHERWISE SPECIFIED:

- 1 PLACE ± 0.3 mm
- 2 PLACE ± 0.03 mm

MATERIAL: S.A.E. 1020 HRS

SEE PAGE B-1.1 FOR GLOBAL MATERIALS CHART

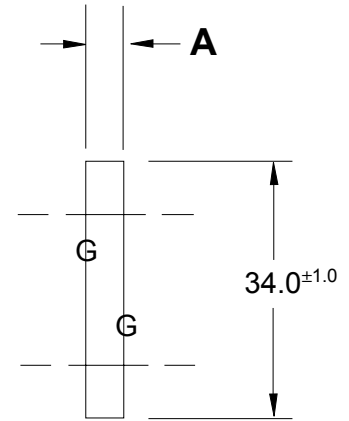
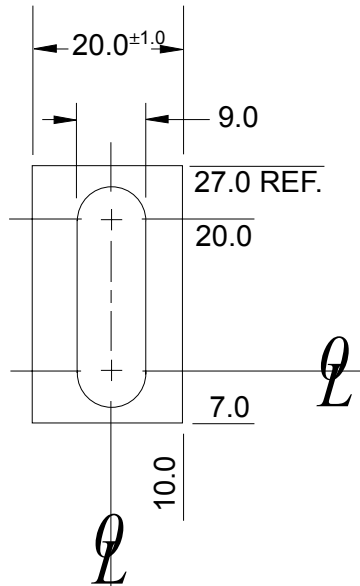

NAAMS CODE	A
ASP330S	3.00
ASP332S	3.20
ASP334S	3.40
ASP336S	3.60
ASP338S	3.80
ASP340S	4.00
ASP342S	4.20
ASP344S	4.40
ASP346S	4.60
ASP348S	4.80
ASP350S	5.00
ASP352S	5.20
ASP354S	5.40
ASP356S	5.60
ASP358S	5.80
ASP360S	6.00
ASP362S	6.20
ASP364S	6.40
ASP366S	6.60
ASP368S	6.80
ASP370S	7.00

B

A

**METRIC FITTING SPACERS
LONG SLOT (SMALL)**

A

**DISCONTINUED
See Page J-19**

METRIC FITTING SPACERS 2-SLOT (SMALL)

GLOBAL STANDARD COMPONENTS



Assembly

02/04/20

NOTE:

- 1.) ETCH DIM A ON EDGE OF SPACER
- 2.) ALL DIMENSIONS ARE METRIC
- 3.) BLACK OXIDE FINISH
- 4.) SURFACES TO BE FLAT AND PARALLEL TO WITHIN 0.015 mm T.I.R.
- 5.) METRIC TOLERANCES: UNLESS OTHERWISE SPECIFIED:

- 1 PLACE ± 0.3 mm
- 2 PLACE ± 0.03 mm

MATERIAL: S.A.E. 1020 HRS
SEE PAGE B-1.1 FOR GLOBAL MATERIALS CHART

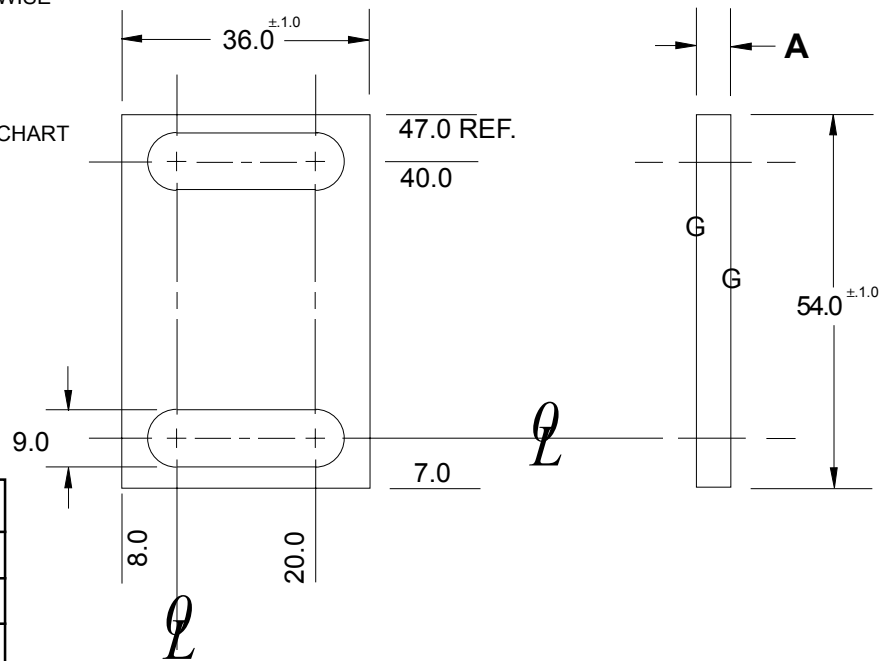

NAAMS CODE	A
ASP630S	3.00
ASP632S	3.20
ASP634S	3.40
ASP636S	3.60
ASP638S	3.80
ASP640S	4.00
ASP642S	4.20
ASP644S	4.40
ASP646S	4.60
ASP648S	4.80
ASP650S	5.00
ASP652S	5.20
ASP654S	5.40
ASP656S	5.60
ASP658S	5.80
ASP660S	6.00
ASP662S	6.20
ASP664S	6.40
ASP666S	6.60
ASP668S	6.80
ASP670S	7.00

B

A

CONSTRUCTION SPACER 3-SLOT

GLOBAL STANDARD COMPONENTS



Assembly

02/04/20

C

E

B

A

D

NOTE:

- 1.) ETCH DIM A ON EDGE OF SPACER
 - 2.) BLACK OXIDE FINISH
 - 3.) SURFACES TO BE FLAT AND PARALLEL TO WITHIN 0.015 T.I.R.
 - 4.) METRIC TOLERANCES: UNLESS OTHERWISE SPECIFIED:
 0 PLACE ± 0.5
 1 PLACE ± 0.3
 - 5.) ALL SLOTS TO BE 10.50 ± 0.20
 - 6.) ALL SLOT LOCATING DIMENSIONS TO BE ± 0.25
- MATERIAL: S.A.E. 1020 HRS
 SEE PAGE B-1.1 FOR GLOBAL MATERIALS CHART

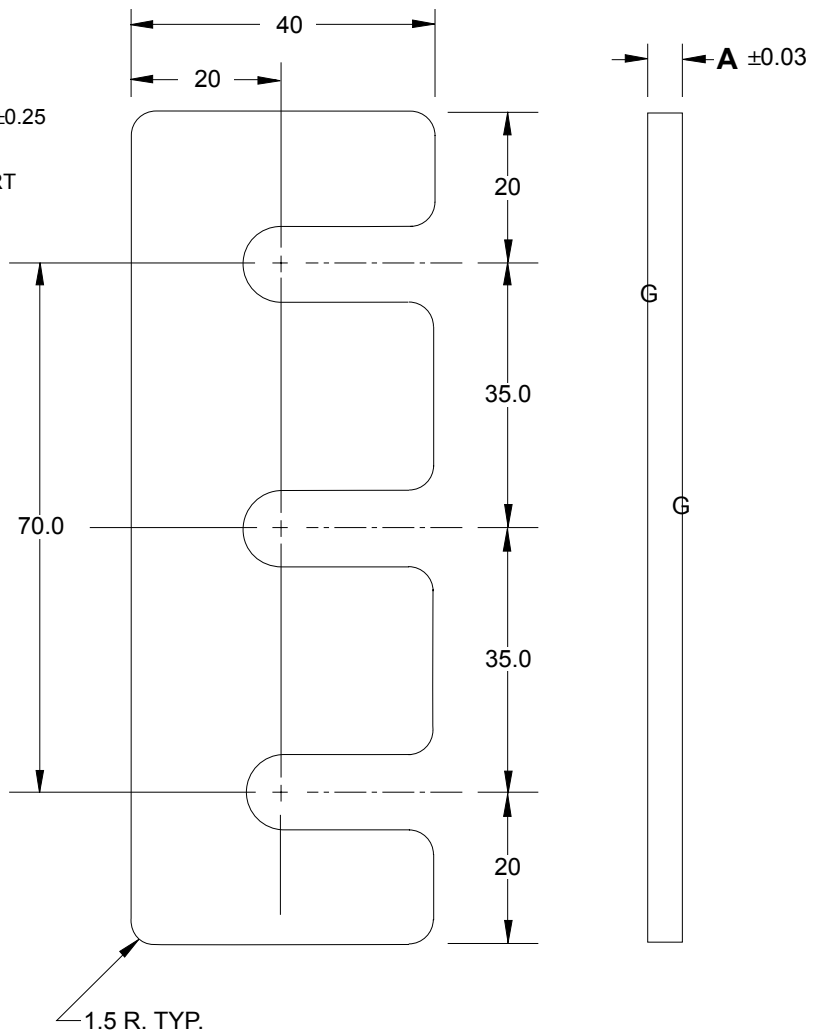

NAAMS CODE	A
ACS330S	3.00
ACS332S	3.20
ACS334S	3.40
ACS336S	3.60
ACS338S	3.80
ACS340S	4.00
ACS342S	4.20

NAAMS CODE	A
ACS344S	4.40
ACS346S	4.60
ACS348S	4.80
ACS350S	5.00
ACS352S	5.20
ACS354S	5.40
ACS356S	5.60

NAAMS CODE	A
ACS358S	5.80
ACS360S	6.00
ACS362S	6.20
ACS364S	6.40
ACS366S	6.60
ACS368S	6.80
ACS370S	7.00

SPACER FOR 60 x 60 AND 70 x 70 MOUNTING

GLOBAL STANDARD COMPONENTS



Assembly

02/04/20

NOTE:

- 1.) ETCH DIM A ON EDGE OF SPACER
- 2.) BLACK OXIDE FINISH
- 3.) SURFACES TO BE FLAT AND PARALLEL TO WITHIN 0.015 T.I.R.
- 4.) METRIC TOLERANCES: UNLESS OTHERWISE SPECIFIED:

MATERIAL: S.A.E. 1020 HRS
SEE PAGE B-1.1 FOR GLOBAL MATERIALS CHART

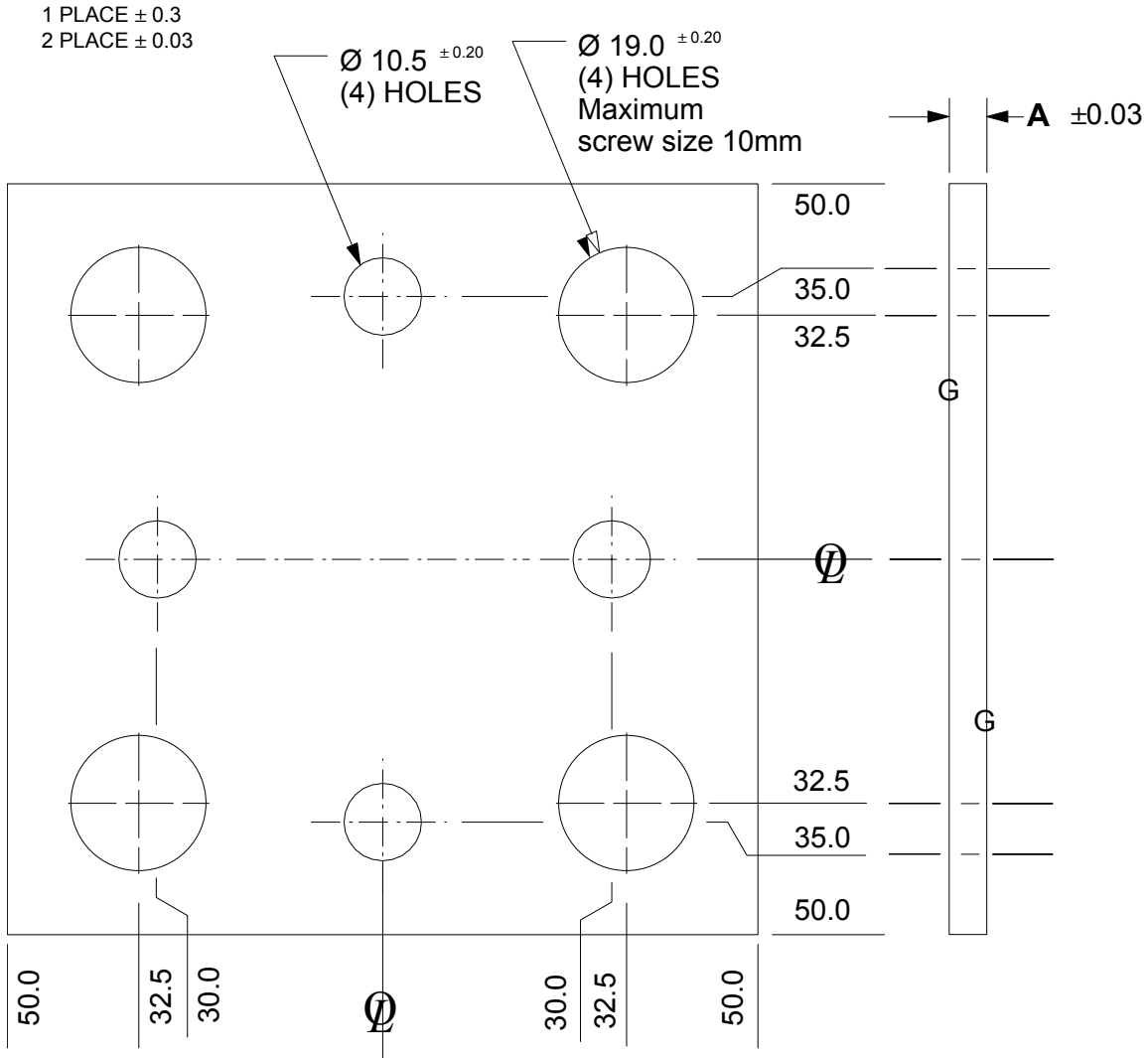

NAAMS CODE	A
ACS630	3.00
ACS632	3.20
ACS634	3.40
ACS636	3.60
ACS638	3.80
ACS640	4.00
ACS642	4.20

NAAMS CODE	A
ACS644	4.40
ACS646	4.60
ACS648	4.80
ACS650	5.00
ACS652	5.20
ACS654	5.40
ACS656	5.60

NAAMS CODE	A
ACS658	5.80
ACS660	6.00
ACS662	6.20
ACS664	6.40
ACS666	6.60
ACS668	6.80
ACS670	7.00

A
E
D
B
C

METRIC FITTING SHIMS 2-SLOT

GLOBAL STANDARD COMPONENTS



Assembly

12/02/19

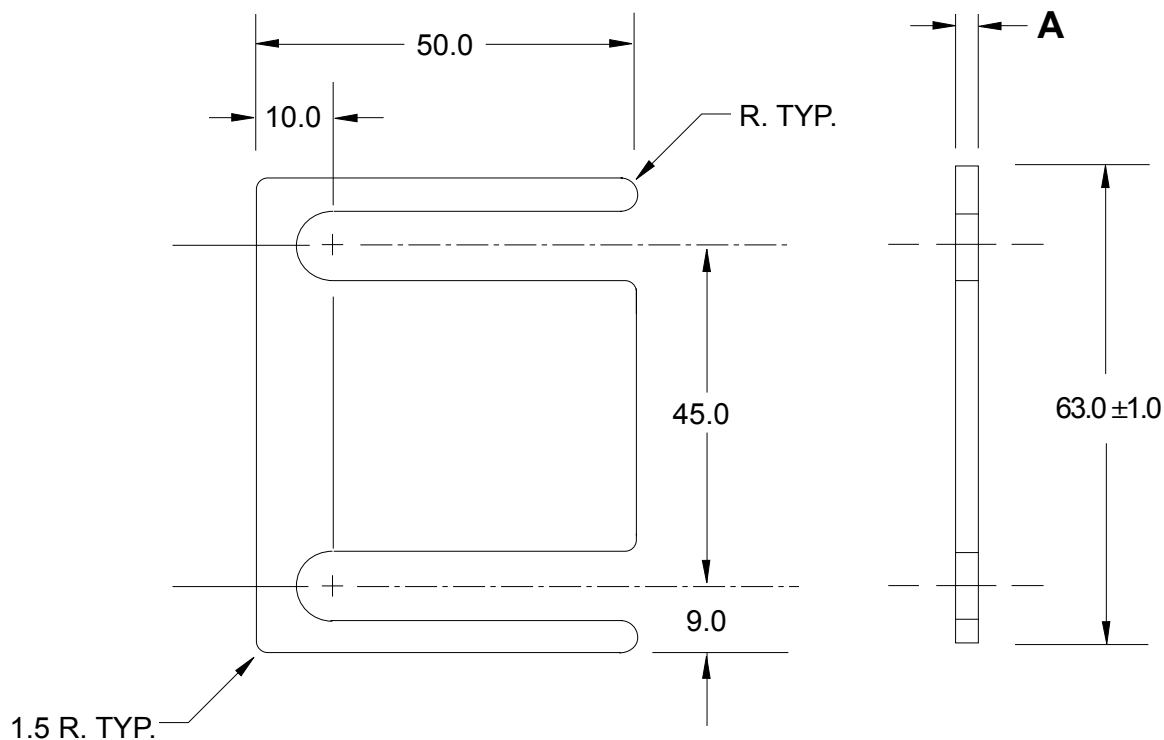

NOTE:

- 1.) ALL SLOTS TO BE 10.5 ± 0.20
- 2.) ROUNDED ENDS OF ALL SLOTS TO BE TRUE RADIUS 1/2 OF WIDTH.
- 3.) ALL SLOT LOCATING DIMENSIONS TO BE ± 0.25
- 4.) MAT'L COLD ROLLED STRIP STEEL S.A.E. 1010 FULL HARD

METRIC DIMENSIONAL TOLERANCES

UNLESS OTHERWISE SPECIFIED:

1 PLACE: ± 0.3

2 PLACE: ± 0.03

SEE PAGE B-1.1 FOR GLOBAL MATERIALS CHART

SHIM PACK ASH6	
QTY.	NAAMS CODE
2	ASH602
3	ASH605
1	ASH610
1	ASH620

NAAMS CODE	A	SURFACE
ASH602	0.25	NONE
ASH605	0.50	YELLOW OR GOLD*
ASH610	1.00	BLACK OXIDE
ASH620	2.00	NONE

* = RoHS COMPLIANT TRIVALENT CHROMATE

A

B

CONSTRUCTION SHIM 2-SLOT

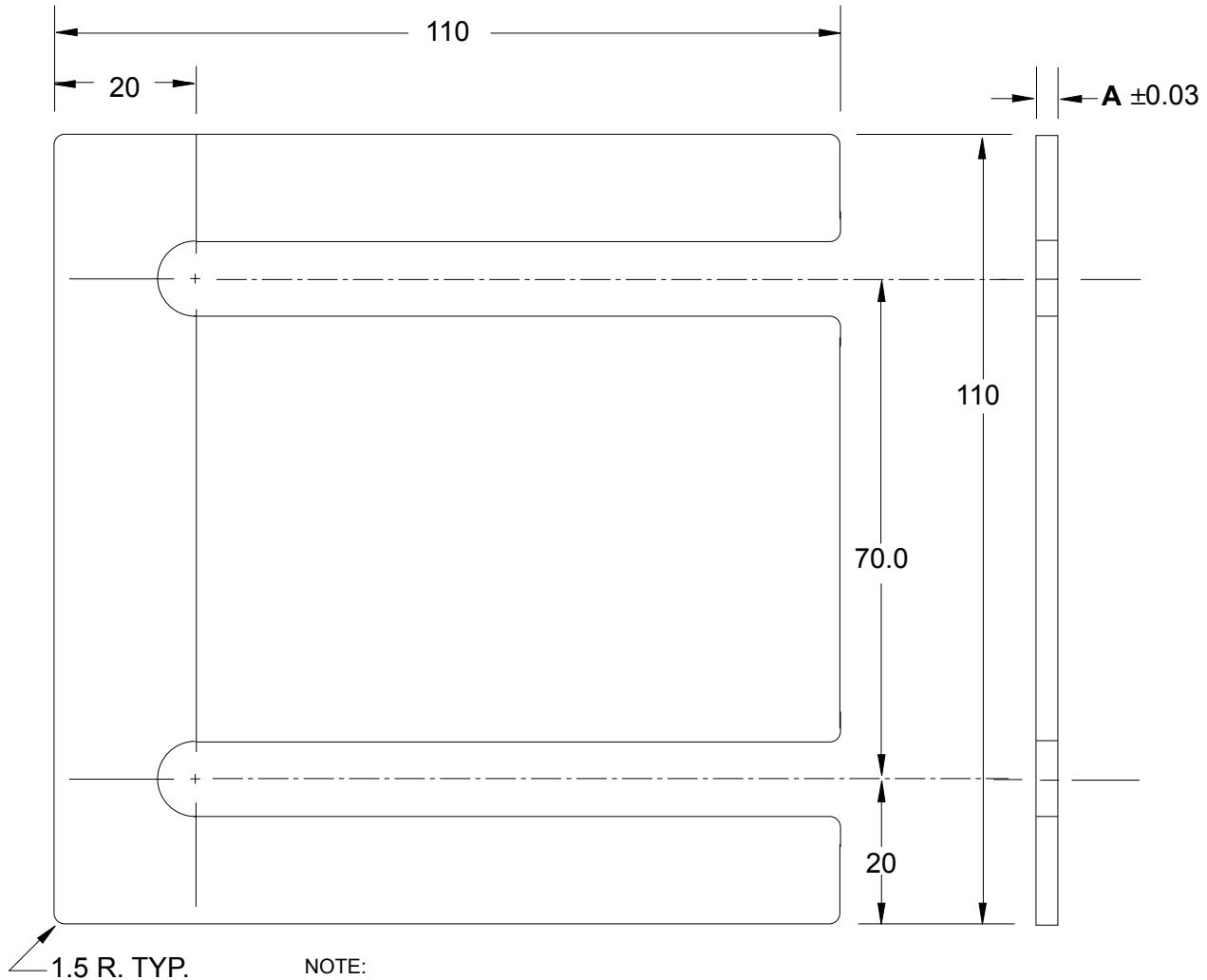

NOTE:

- 1.) ALL SLOTS TO BE 10.5 ± 0.20
- 2.) ROUNDED ENDS OF ALL SLOTS TO BE TRUE RADIUS 1/2 OF WIDTH.
- 3.) ALL SLOT LOCATING DIMENSIONS TO BE ± 0.25
- 4.) MAT'L COLD ROLLED STRIP STEEL S.A.E. 1010 FULL HARD

METRIC DIMENSIONAL TOLERANCES

UNLESS OTHERWISE SPECIFIED:

0 PLACE: ± 0.5

1 PLACE: ± 0.3

SEE PAGE B-1.1 FOR GLOBAL MATERIALS CHART

SHIM PACK ACH6	
QTY.	NAAMS CODE
2	ACH602
3	ACH605
1	ACH610
1	ACH620

NAAMS CODE	A	SURFACE
ACH602	0.25	NONE
ACH605	0.50	YELLOW OR GOLD*
ACH610	1.00	BLACK OXIDE
ACH620	2.00	NONE

* = RoHS COMPLIANT TRIVALENT CHROMATE

METRIC FITTING SPACERS 5-HOLE

GLOBAL STANDARD COMPONENTS



Assembly

02/04/20

NOTE:

- 1.) ETCH DIM A ON EDGE OF SPACER
- 2.) ALL DIMENSIONS ARE METRIC
- 3.) BLACK OXIDE FINISH
- 4.) SURFACES TO BE FLAT AND PARALLEL TO WITHIN 0.015 mm T.I.R.
- 5.) METRIC TOLERANCES: UNLESS OTHERWISE SPECIFIED:

- 1 PLACE ± 0.3 mm
- 2 PLACE ± 0.03 mm

MATERIAL: S.A.E. 1020 HRS
SEE PAGE B-1.1 FOR GLOBAL MATERIALS CHART

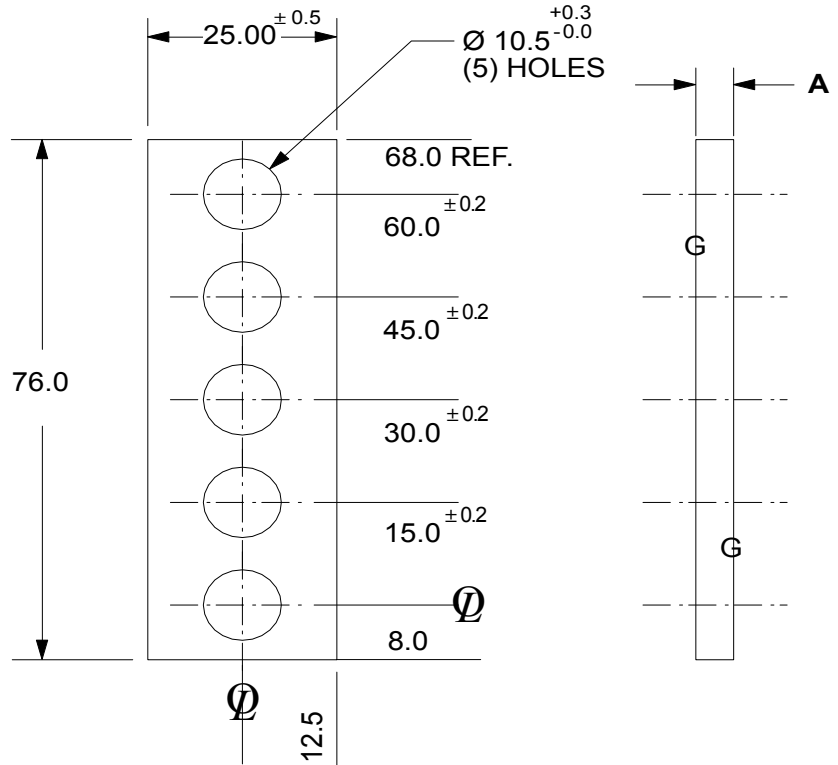

NAAMS CODE	A
ASP530	3.00
ASP532	3.20
ASP534	3.40
ASP536	3.60
ASP538	3.80
ASP540	4.00
ASP542	4.20
ASP544	4.40
ASP546	4.60
ASP548	4.80
ASP550	5.00
ASP552	5.20
ASP554	5.40
ASP556	5.60
ASP558	5.80
ASP560	6.00
ASP562	6.20
ASP564	6.40
ASP566	6.60
ASP568	6.80
ASP570	7.00

D
A

B
C

METRIC FITTING SHIMS 5-SLOT

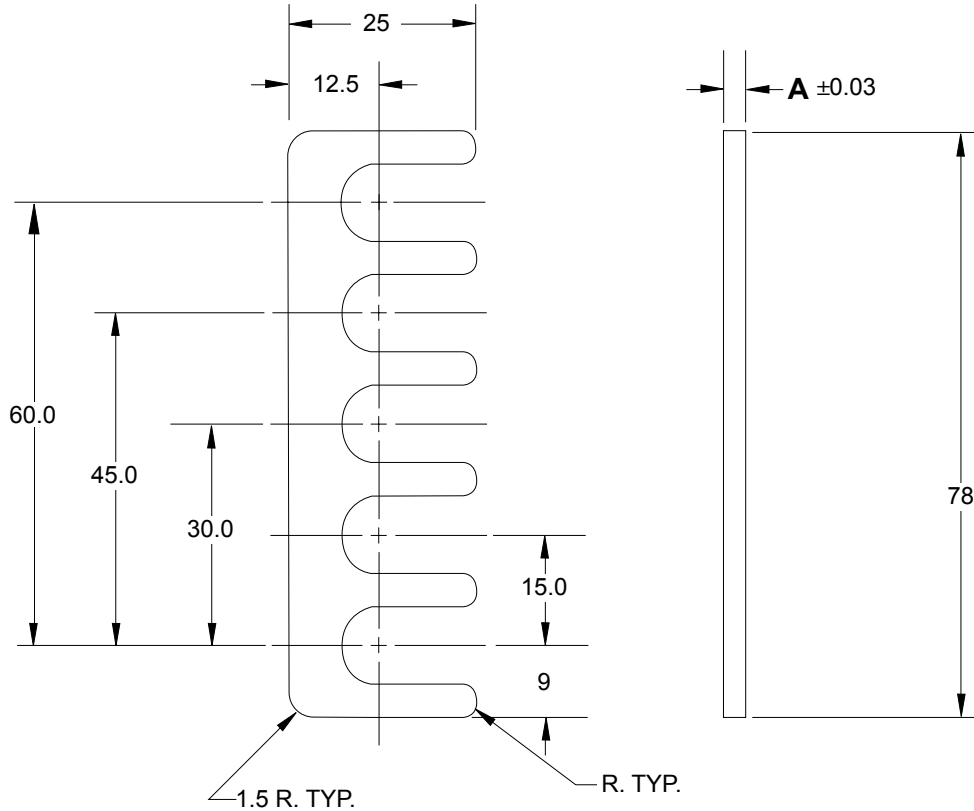

NOTE:

- 1.) ALL SLOTS TO BE 10.5 ± 0.20
- 2.) ROUNDED ENDS OF ALL SLOTS TO BE TRUE RADIUS 1/2 OF WIDTH.
- 3.) ALL SLOT LOCATING DIMENSIONS TO BE ± 0.25
- 4.) MAT'L COLD ROLLED STRIP STEEL S.A.E. 1010 FULL HARD

METRIC DIMENSIONAL TOLERANCES
UNLESS OTHERWISE SPECIFIED:

0 PLACE: ± 0.5
1 PLACE: ± 0.3

SEE PAGE B-1.1 FOR GLOBAL MATERIALS CHART

SHIM PACK ASH5	
QTY.	NAAMS CODE
2	ASH502
3	ASH505
1	ASH510
1	ASH520

NAAMS CODE	A	SURFACE
ASH502	0.25	NONE
ASH505	0.50	YELLOW OR GOLD*
ASH510	1.00	BLACK OXIDE
ASH520	2.00	NONE

* = RoHS COMPLIANT TRIVALENT CHROMATE

B

A

D

C

E

METRIC FITTING SHIMS 20 mm SERIES 1 - SLOT

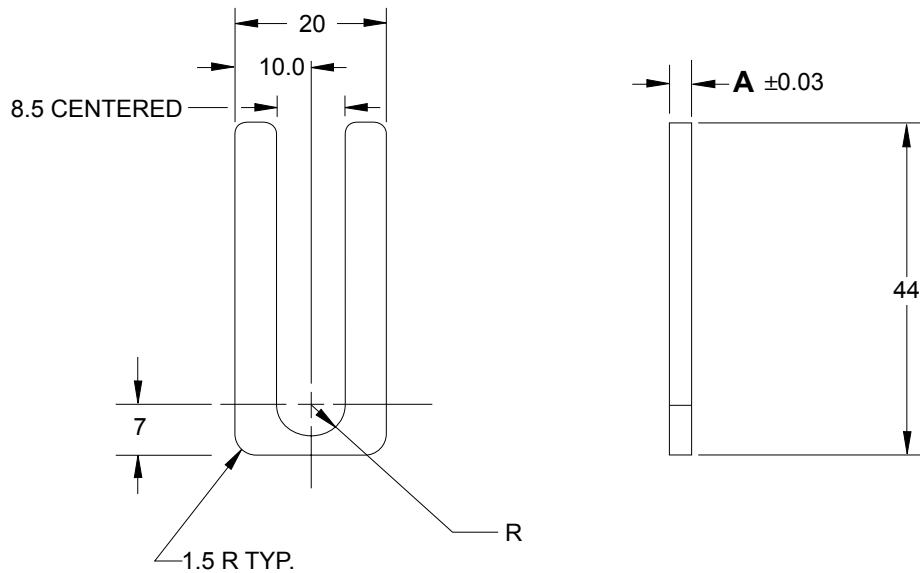

METRIC DIMENSIONAL TOLERANCES
UNLESS OTHERWISE SPECIFIED:

0 PLACE: ± 0.5

1 PLACE: ± 0.3

MATERIAL : COLD ROLLED STRIP STEEL S.A.E. 1010 FULL HARD
SEE PAGE B-1.1 FOR GLOBAL MATERIALS CHART

SHIM PACK ASH1N	
QTY.	NAAMS CODE
2	ASH102N
3	ASH105N
1	ASH110N
1	ASH120N

NAAMS CODE	A	SURFACE
ASH102N	0.25	NONE
ASH105N	0.50	YELLOW OR GOLD*
ASH110N	1.00	BLACK OXIDE
ASH120N	2.00	NONE

* = RoHS COMPLIANT TRIVALENT CHROMATE

B

A

C

METRIC FITTING SHIMS 20 mm SERIES 3 - SLOT

GLOBAL STANDARD COMPONENTS



Assembly

12/02/19

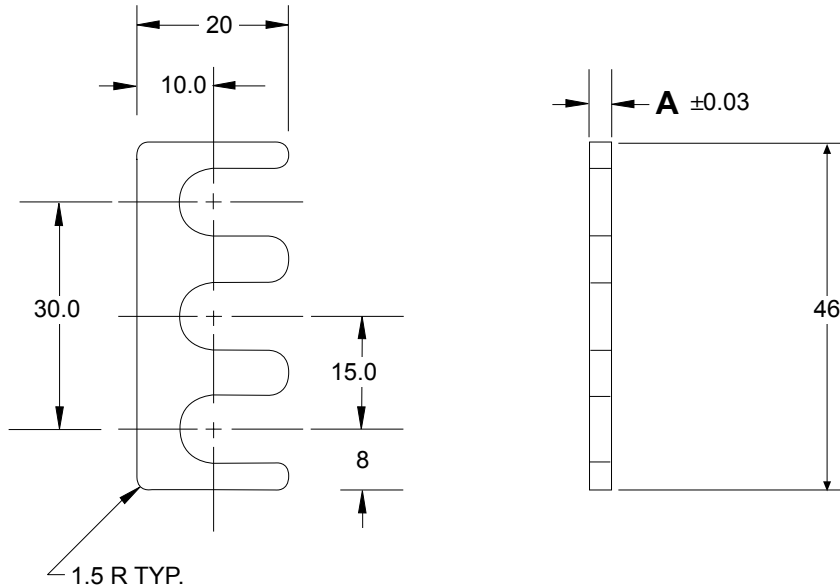

NOTE:

- 1.) ALL SLOTS TO BE 9.0 ± 0.20
- 2.) ROUNDED ENDS OF ALL SLOTS TO BE TRUE RADIUS 1/2 OF WIDTH.
- 3.) MAT'L COLD ROLLED STRIP STEEL S.A.E. 1010 FULL HARD

METRIC DIMENSIONAL TOLERANCES
UNLESS OTHERWISE SPECIFIED:

0 PLACE: ± 0.5

1 PLACE: ± 0.3

SEE PAGE B-1.1 FOR GLOBAL MATERIALS CHART

SHIM PACK ASH3N	
QTY.	NAAMS CODE
2	ASH302N
3	ASH305N
1	ASH310N
1	ASH320N

NAAMS CODE	A	SURFACE
ASH302N	0.25	NONE
ASH305N	0.50	YELLOW OR GOLD*
ASH310N	1.00	BLACK OXIDE
ASH320N	2.00	NONE

* = RoHS COMPLIANT TRIVALENT CHROMATE

B

A

C

METRIC FITTING SHIMS 20 mm SERIES 4 - SLOT

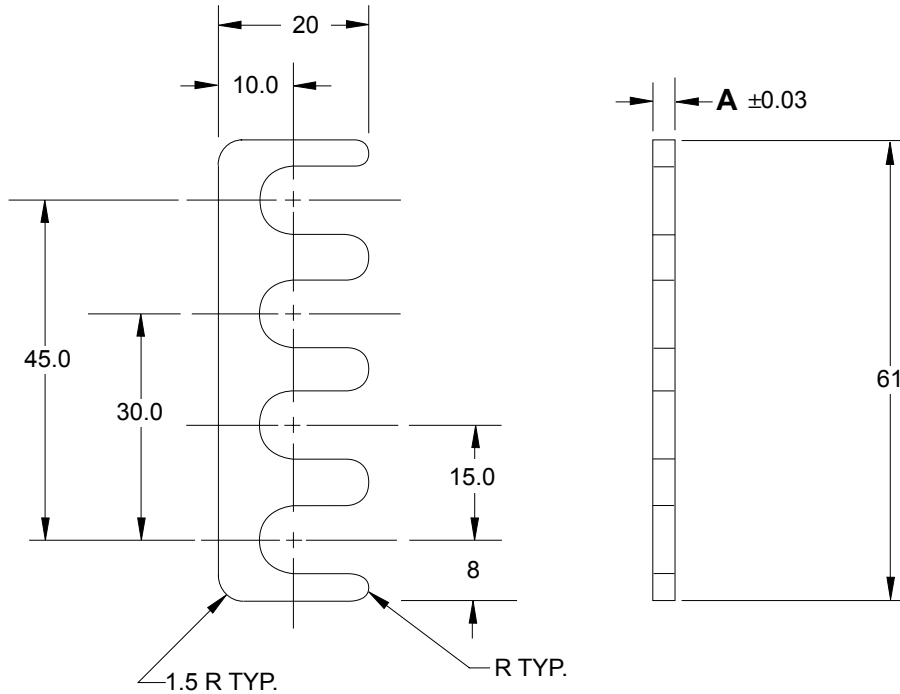

NOTE:

- 1.) ALL SLOTS TO BE 9.0 ± 0.20
- 2.) ROUNDED ENDS OF ALL SLOTS TO BE TRUE RADIUS 1/2 OF WIDTH.
- 3.) MAT'L COLD ROLLED STRIP STEEL S.A.E. 1010 FULL HARD

METRIC DIMENSIONAL TOLERANCES
UNLESS OTHERWISE SPECIFIED:

0 PLACE: ± 0.5

1 PLACE: ± 0.3

SEE PAGE B-1.1 FOR GLOBAL MATERIALS CHART

SHIM PACK ASH4N	
QTY.	NAAMS CODE
2	ASH402N
3	ASH405N
1	ASH410N
1	ASH420N

NAAMS CODE	A	SURFACE
ASH402N	0.25	NONE
ASH405N	0.50	YELLOW OR GOLD*
ASH410N	1.00	BLACK OXIDE
ASH420N	2.00	NONE

* = RoHS COMPLIANT TRIVALENT CHROMATE

B

A

C

METRIC FITTING SPACERS 20mm SERIES FOR 3-HOLE COMPONENTS

GLOBAL STANDARD COMPONENTS



Assembly

02/04/20

B

A

NOTE:

- 1.) ETCH DIM A ON EDGE OF SPACER
- 2.) ALL DIMENSIONS ARE METRIC
- 3.) BLACK OXIDE FINISH
- 4.) SURFACES TO BE FLAT AND PARALLEL TO WITHIN 0.015 T.I.R.
- 5.) TOLERANCES:

- 1 PLACE ± 0.3
- 2 PLACE ± 0.03

MATERIAL: S.A.E. 1020 HRS

SEE PAGE B-1.1 FOR GLOBAL MATERIALS CHART

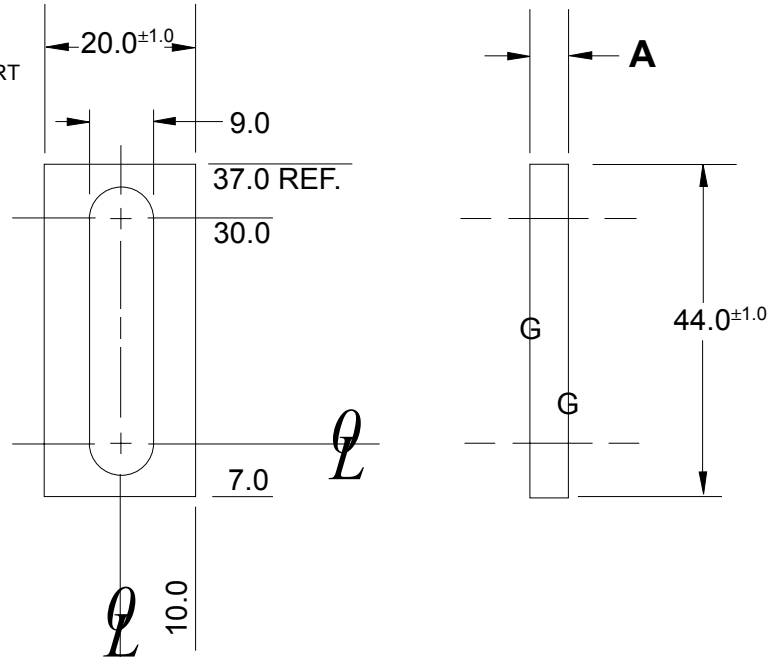

NAAMS CODE	A
ASP430S	3.00
ASP432S	3.20
ASP434S	3.40
ASP436S	3.60
ASP438S	3.80
ASP440S	4.00
ASP442S	4.20
ASP444S	4.40
ASP446S	4.60
ASP448S	4.80
ASP450S	5.00
ASP452S	5.20
ASP454S	5.40
ASP456S	5.60
ASP458S	5.80
ASP460S	6.00
ASP462S	6.20
ASP464S	6.40
ASP466S	6.60
ASP468S	6.80
ASP470S	7.00

METRIC FITTING SPACERS

20 mm SERIES

4 - HOLE

GLOBAL STANDARD COMPONENTS



Assembly

02/04/20

NOTE:

- 1.) ETCH DIM A ON EDGE OF SPACER
- 2.) BLACK OXIDE FINISH
- 3.) SURFACES TO BE FLAT AND PARALLEL TO WITHIN 0.015 mm T.I.R.
- 4.) MATERIAL: STEEL
- 5.) TOLERANCES:

- 1 PLACE ± 0.3
- 2 PLACE ± 0.03

MATERIAL: S.A.E. 1020 HRS

SEE PAGE B-1.1 FOR GLOBAL MATERIALS CHART

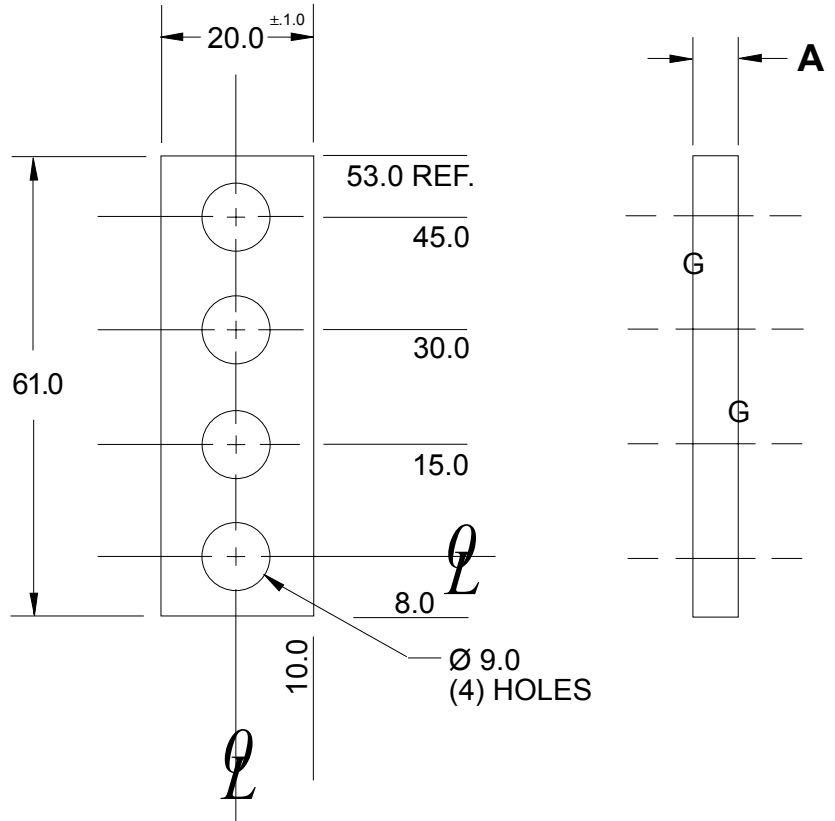

C

A

B

NAAMS CODE	A
ASP430N	3.00
ASP432N	3.20
ASP434N	3.40
ASP436N	3.60
ASP438N	3.80
ASP440N	4.00
ASP442N	4.20
ASP444N	4.40
ASP446N	4.60
ASP448N	4.80
ASP450N	5.00
ASP452N	5.20
ASP454N	5.40
ASP456N	5.60
ASP458N	5.80
ASP460N	6.00
ASP462N	6.20
ASP464N	6.40
ASP466N	6.60
ASP468N	6.80
ASP470N	7.00

METRIC FITTING SPACERS

20 mm

6 - HOLE

GLOBAL STANDARD COMPONENTS



Assembly

02/04/20

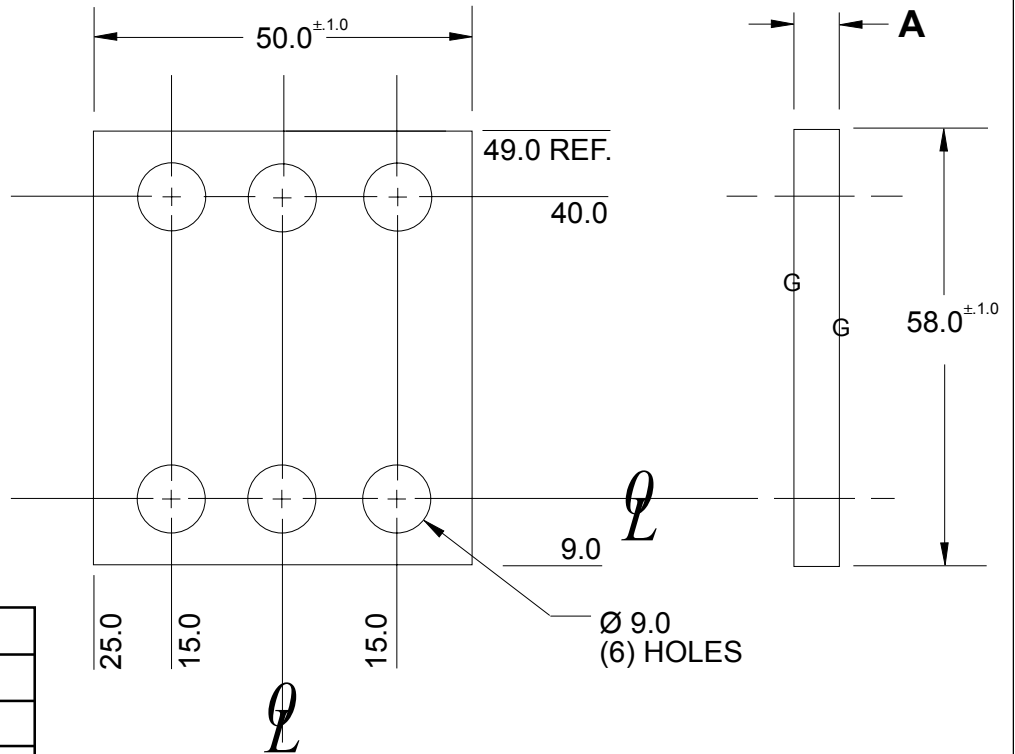

NAAMS CODE	A
ASP630N	3.00
ASP632N	3.20
ASP634N	3.40
ASP636N	3.60
ASP638N	3.80
ASP640N	4.00
ASP642N	4.20
ASP644N	4.40
ASP646N	4.60
ASP648N	4.80
ASP650N	5.00
ASP652N	5.20
ASP654N	5.40
ASP656N	5.60
ASP658N	5.80
ASP660N	6.00
ASP662N	6.20
ASP664N	6.40
ASP666N	6.60
ASP668N	6.80
ASP670N	7.00

NOTE:

- 1.) ETCH DIM A ON EDGE OF SPACER
- 2.) BLACK OXIDE FINISH
- 3.) SURFACES TO BE FLAT AND PARALLEL TO WITHIN 0.015 mm T.I.R.

TOLERANCES:

- 1 PLACE ± 0.3
- 2 PLACE ± 0.03

MATERIAL: S.A.E. 1020 HRS

SEE PAGE B-1.1 FOR GLOBAL MATERIALS CHART

B

A

METRIC FITTING SPACER - 2 HOLE

NOTE:

- 1) ETCH DIM A ON EDGE OF SPACER
- 2) ALL DIMENSIONS ARE METRIC
- 3) BLACK OXIDE FINISH
- 4) SURFACE TO BE FLAT AND PARALLEL TO WITHIN 0.015 T.I.R.
- 5) METRIC TOLERANCES: UNLESS OTHERWISE SPECIFIED
 - 1 PLACE $\pm 0.3\text{mm}$
 - 2 PLACE $\pm 0.03\text{mm}$

BLACK OXIDE

MATERIAL: S.A.E. 1020 HRS
SEE PAGE B-1.1 FOR GLOBAL MATERIALS CHART

B

A

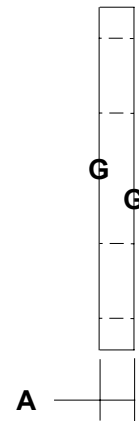
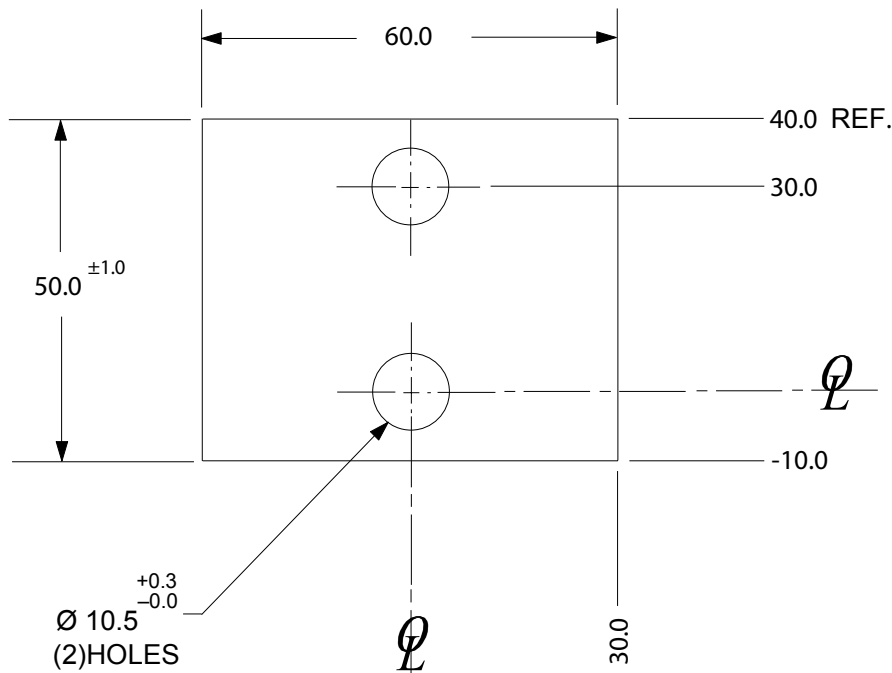

NAAMS CODE	A
ASP230	3.00
ASP232	3.20
ASP234	3.40
ASP236	3.60
ASP238	3.80
ASP240	4.00
ASP242	4.20
ASP244	4.40
ASP246	4.60
ASP248	4.80
ASP250	5.00
ASP252	5.20
ASP254	5.40
ASP256	5.60
ASP258	5.80
ASP260	6.00
ASP262	6.20
ASP264	6.40
ASP266	6.60
ASP268	6.80
ASP270	7.00

SPACER FOR SHOCK BRACKET

NOTE:

ETCH DIM A ON EDGE OF SPACER
 BLACK OXIDE FINISH
 SURFACE TO BE FLAT AND PARALLEL TO WITHIN 0.015 T.I.R.
 METRIC TOLERANCES: UNLESS OTHERWISE SPECIFIED
 1 PLACE $\pm 0.3\text{mm}$
 2 PLACE $\pm 0.03\text{mm}$

MATERIAL: S.A.E. 1020 HRS
 SEE PAGE B-1.1 FOR GLOBAL MATERIALS CHART

B
A

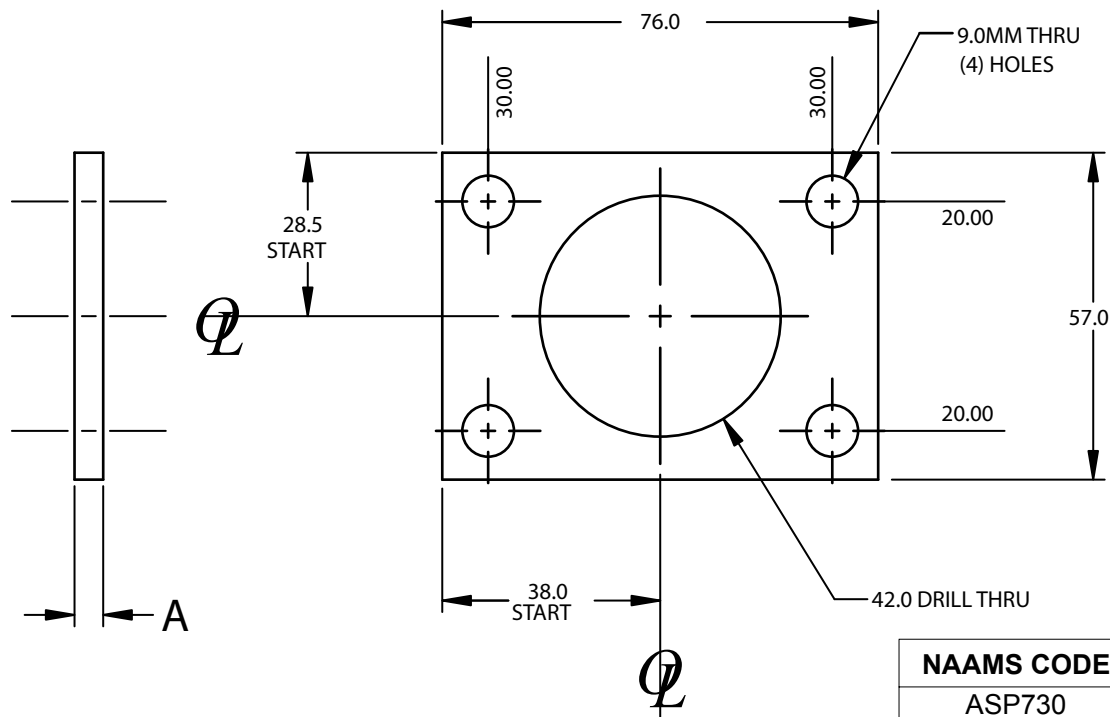

NAAMS CODE	A
ASP730	3.00
ASP732	3.20
ASP734	3.40
ASP736	3.60
ASP738	3.80
ASP740	4.00
ASP742	4.20
ASP744	4.40
ASP746	4.60
ASP748	4.80
ASP750	5.00
ASP752	5.20
ASP754	5.40
ASP756	5.60
ASP758	5.80
ASP760	6.00
ASP762	6.20
ASP764	6.40
ASP766	6.60
ASP768	6.80
ASP770	7.00

METRIC FITTING SPACERS

16 mm SERIES

4 - HOLE

GLOBAL STANDARD COMPONENTS



Assembly

03/19/21

NOTE:

- 1.) ETCH DIM A ON EDGE OF SPACER
- 2.) BLACK OXIDE FINISH
- 3.) SURFACES TO BE FLAT AND PARALLEL TO WITHIN 0.015 mm T.I.R.
- 4.) MATERIAL: STEEL
- 5.) TOLERANCES:
 1 PLACE ± 0.3
 2 PLACE ± 0.03

MATERIAL: S.A.E. 1020 HRS

SEE PAGE B-1.1 FOR GLOBAL MATERIALS CHART

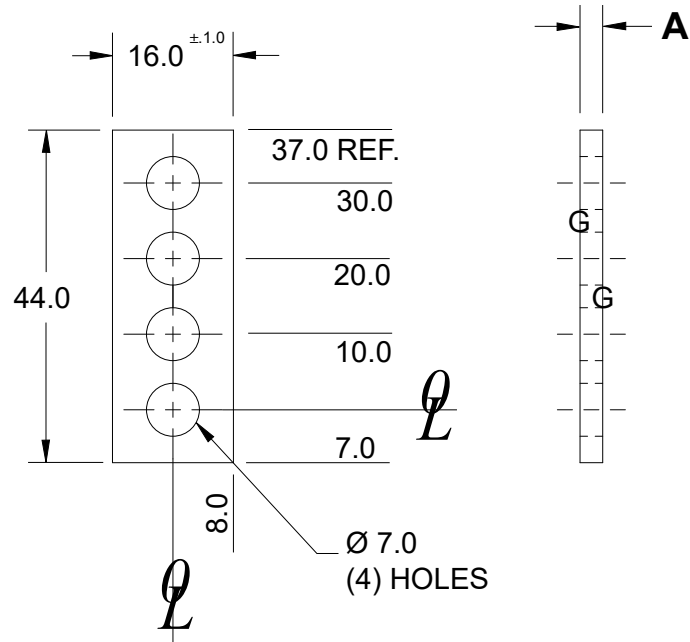

NAAMS CODE	A
ASP830	3.00
ASP832	3.20
ASP834	3.40
ASP836	3.60
ASP838	3.80
ASP840	4.00
ASP842	4.20
ASP844	4.40
ASP846	4.60
ASP848	4.80
ASP850	5.00
ASP852	5.20
ASP854	5.40
ASP856	5.60
ASP858	5.80
ASP860	6.00
ASP862	6.20
ASP864	6.40
ASP866	6.60
ASP868	6.80
ASP870	7.00