

BASES INDEX

PAGE	DATE	DESCRIPTION	DISCONTINUED
D-1	09/20/13	Bases Index	
D-1.1	06/24/21	Bases Index	
D-2	04/15/20	Preferred Base Sizes	X
D-3	04/15/20	Base ASB1212	X
D-4	04/15/20	Base ASB1218	X
D-5	04/15/20	Base ASB1224	X
D-6	04/15/20	Base ASB1818	X
D-7	04/15/20	Base ASB1824	X
D-8	04/15/20	Base ASB1830	X
D-9	04/15/20	Base ASB1836	X
D-10	04/15/20	Base ASB2424	X
D-11	04/15/20	Base ASB2430	X
D-12	04/15/20	Base ASB2436	X
D-13	02/09/06	Standard Base Leveling Method #1	
D-14	03/11/98	Standard Base Leveling Method #2	
D-15	04/29/98	Leveling Method #3 Heavy Frames That Need To Be Leveled	
D-16	03/11/98	Leveling Method #4 Frames That Do Not Need To Be Leveled	
D-17	03/11/98	Leveling Method #5 Light Frames That Need To Be Leveled	
D-18	02/13/08	Leveling Method #6 Standard Robot Mounting	
D-19	07/27/07	Anchor Angles	
D-20	09/20/13	Anchor Angles	
D-21	10/29/07	Leveling Floor Plates	
D-22	11/15/05	Leveling Screw Assemblies	
D-23	05/11/22	Robot Risers	X
D-24	05/11/22	Robot Risers	X
D-25	04/08/04	Anchoring Method #7 Standard Robot Mounting	
D-26	04/15/20	Lightweight Bases - Inch	X

BASES INDEX

PAGE	DATE	DESCRIPTION	DISCONTINUED
D-27	04/15/20	Lightweight Bases - Table	X
D-27.1	04/15/20	Lightweight Bases - Metric	X
D-27.2	04/15/20	Lightweight Bases - Table	X
D-27.3	04/15/20	Lightweight Bases - Installation	X
D-28	02/13/08	ROBOT RISER 400kg / 500kg	
D-29	02/13/08	TABLE	
D-30	02/13/08	ROBOT RISER 600kg	
D-31	02/13/08	TABLE	
D-32	02/13/08	ROBOT RISER 700kg	
D-33	02/13/08	TABLE	
D-34	02/15/08	ROBOT RISER CLIP 700kg	
D-35	06/21/24	ROBOT RISER R2000iC 165F/210F/125L	
D-36	06/21/24	ROBOT RISER R2000iC 165F/210F/125L	
D-37	06/21/24	ROBOT RISER R2000iC 165F/210F/125L	
D-38	06/21/24	ROBOT RISER M900iA 260L/350 & M900iB 280L/360/330L	
D-39	06/21/24	ROBOT RISER M900iA 260L/350 & M900iB 280L/360/330L	
D-40	06/21/24	ROBOT RISER M900iA 260L/350 & M900iB 280L/360/330L	

PREFERRED BASE SIZES

GLOBAL STANDARD COMPONENTS



Assembly

04/15/20

	in.	47.2	70.9	94.5
in.	mm	1200	1800	2400
47.2	1200	ASB1212		
70.9	1800	ASB1218	ASB1818	
94.5	2400	ASB1224	ASB1824	ASB2424
118.1	3000		ASB1830	ASB2430
141.7	3600		ASB1836	ASB2436

D

C

B

A

DISCONTINUED

BASES ASB1212

Overall Base Thickness 210
Top Plate 1200 x 1200
Base Footprint 1200 x 1330
All seams completely welded. Stitch welding is not allowed.
Weight 634kg

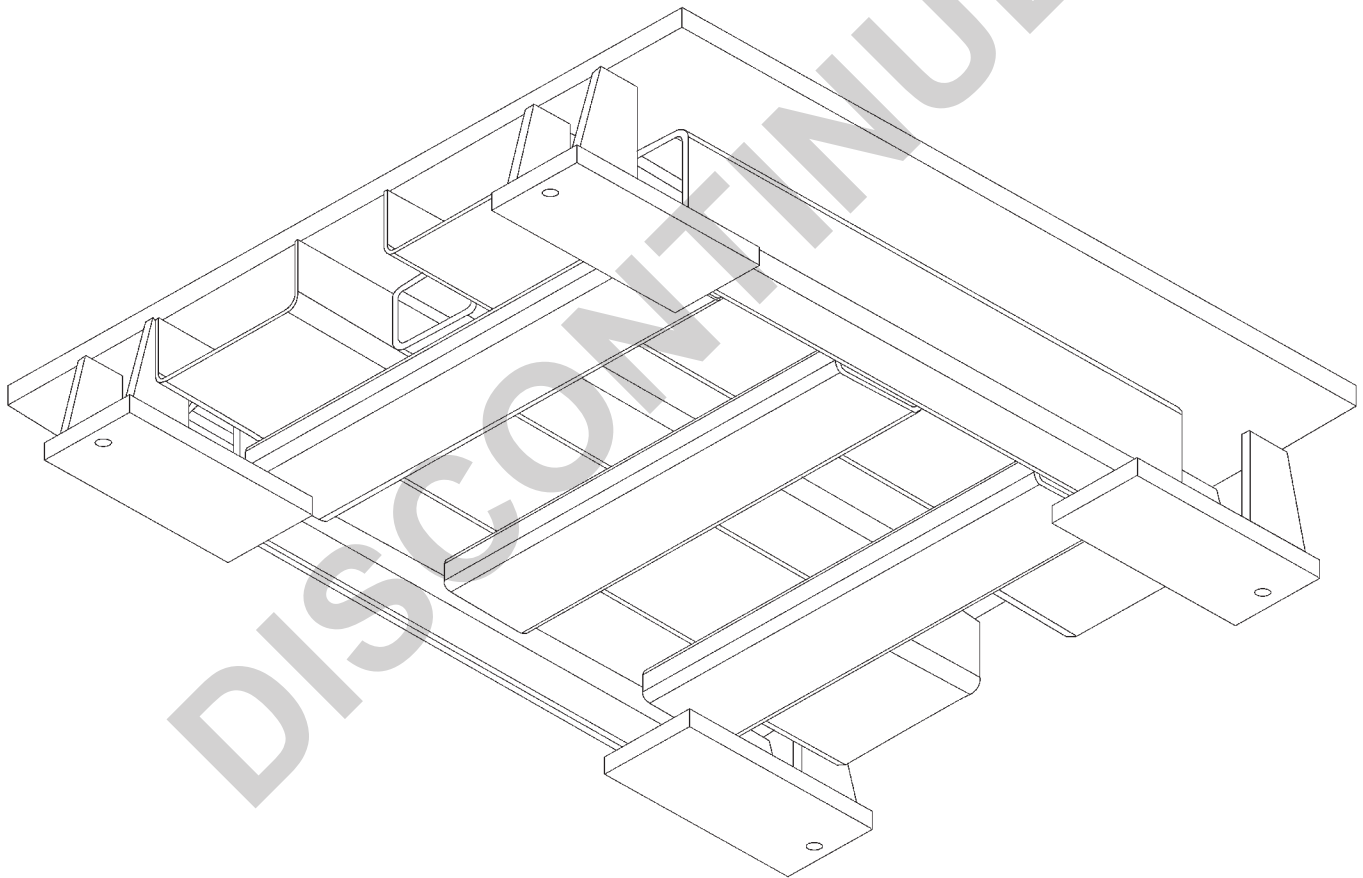

BASES ASB1218

Overall Base Thickness 210
Top Plate 1200 x 1800
Base Footprint 1330 x 1800
All seams completely welded. Stitch welding is not allowed.
Weight 951kg

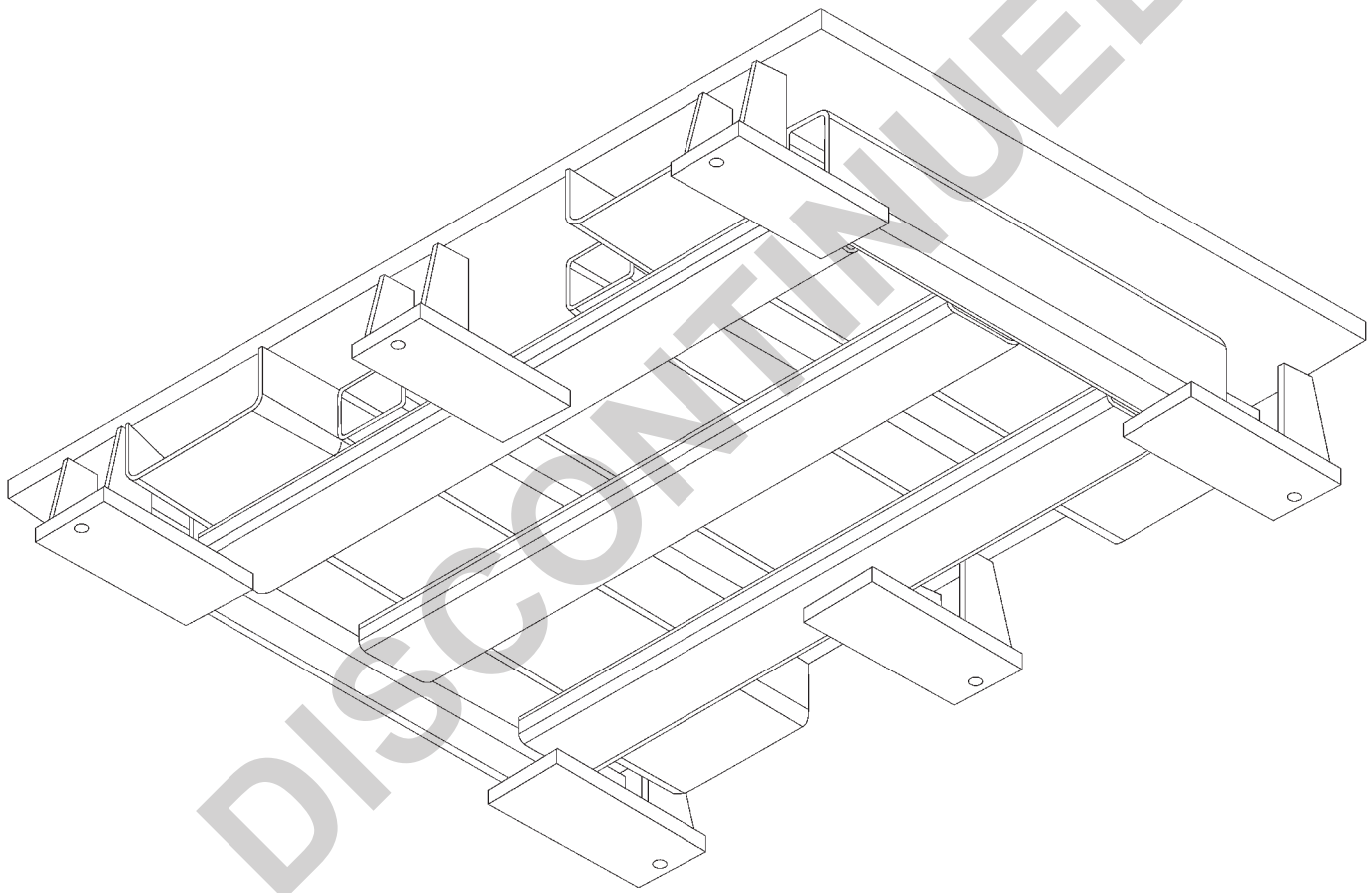

A

C

D

E

B

BASES ASB1224

Overall Base Thickness 210
Top Plate 1200 x 2400
Base Footprint 1330 x 2400
All seams completely welded. Stitch welding is not allowed.
Weight 1,163kg

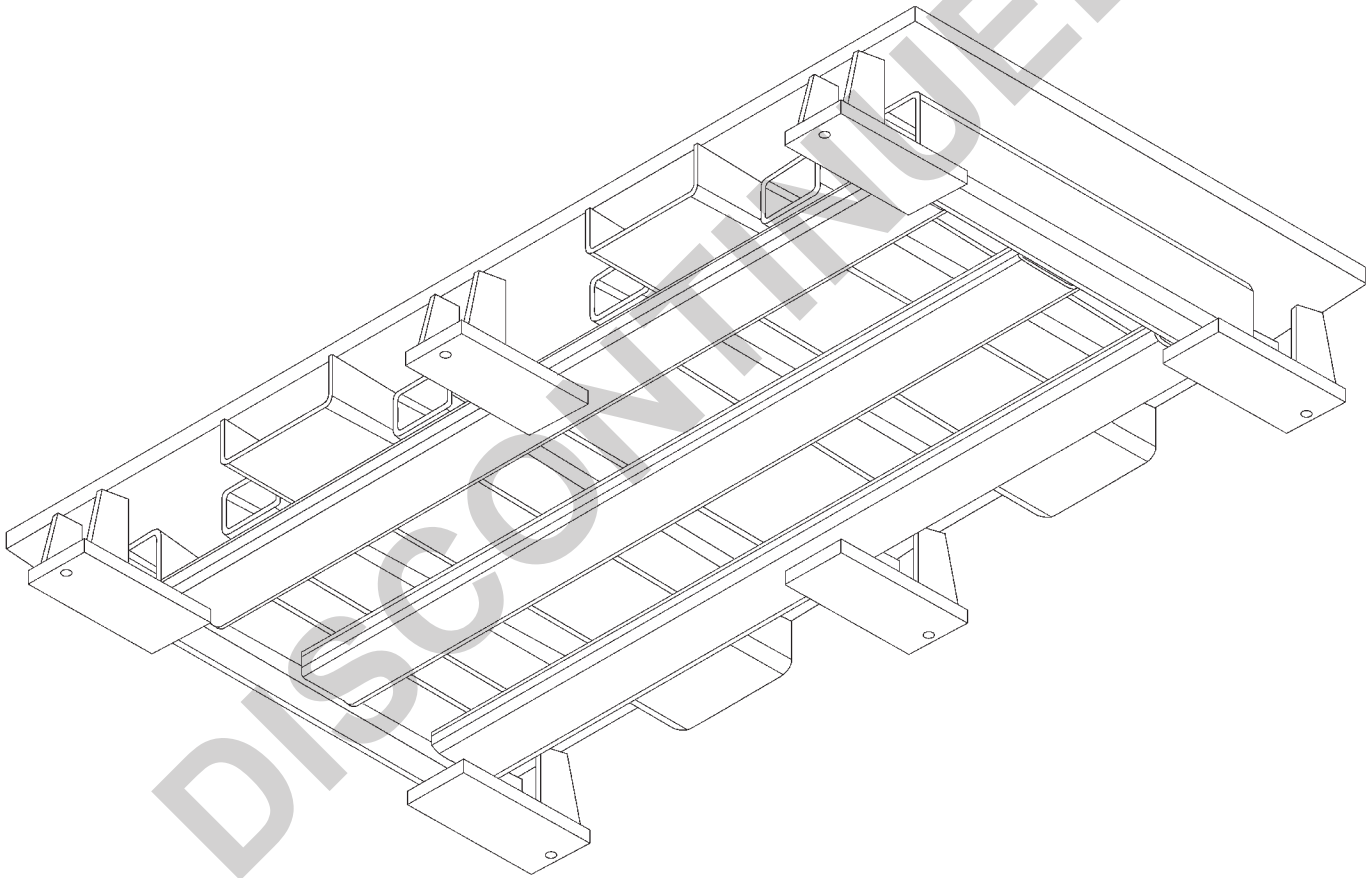

BASES ASB1818

Overall Base Thickness 210
Top Plate 1800 x 1800
Base Footprint 1930 x 1930
All seams completely welded. Stitch welding is not allowed.
Weight 1,356kg

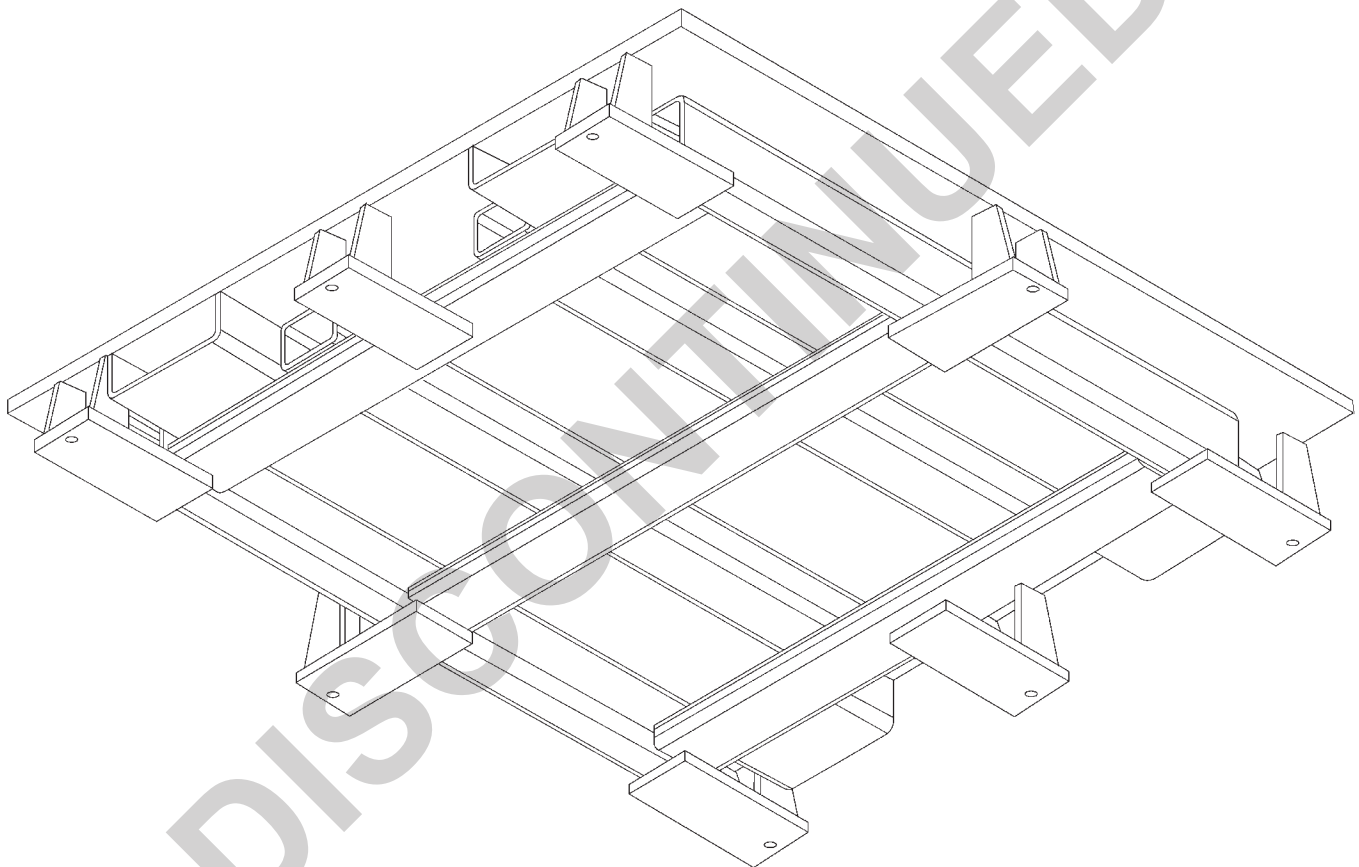

BASES ASB1824

A

Overall Base Thickness 210
Top Plate 1800 x 2400
Base Footprint 1930 x 2530
All seams completely welded. Stitch welding is not allowed.
Weight 1,701kg

C

D

E

B

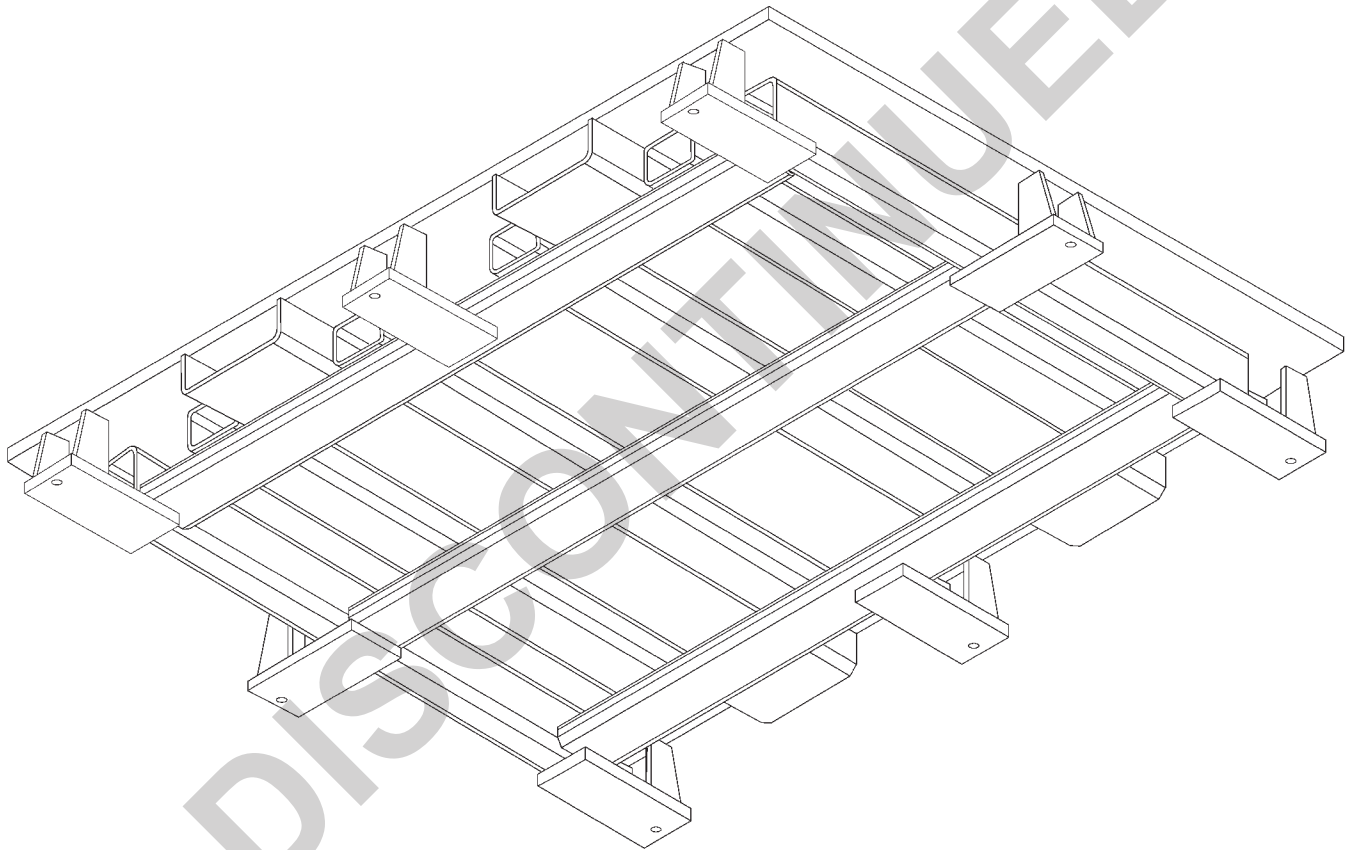

BASES ASB1830

Overall Base Thickness 210
Top Plate 1800 x 3000
Base Footprint 1930 x 3130
All seams completely welded. Stitch welding is not allowed.
Weight 2,294kg

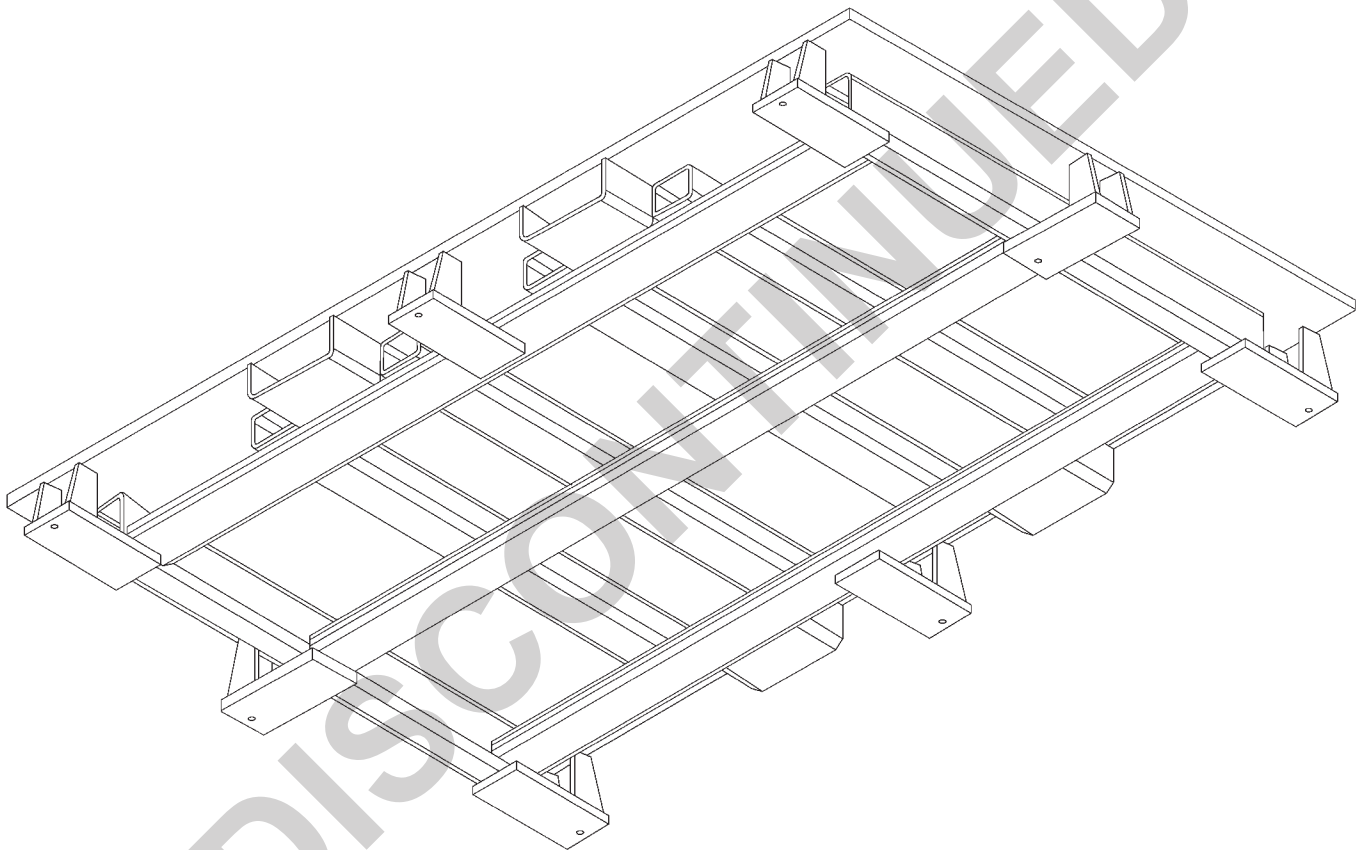

BASES ASB1836

A

Overall Base Thickness 210
Top Plate 1800 x 3600
Base Footprint 1930 x 3730
All seams completely welded. Stitch welding is not allowed.
Weight 2,817kg

C

D

E

B

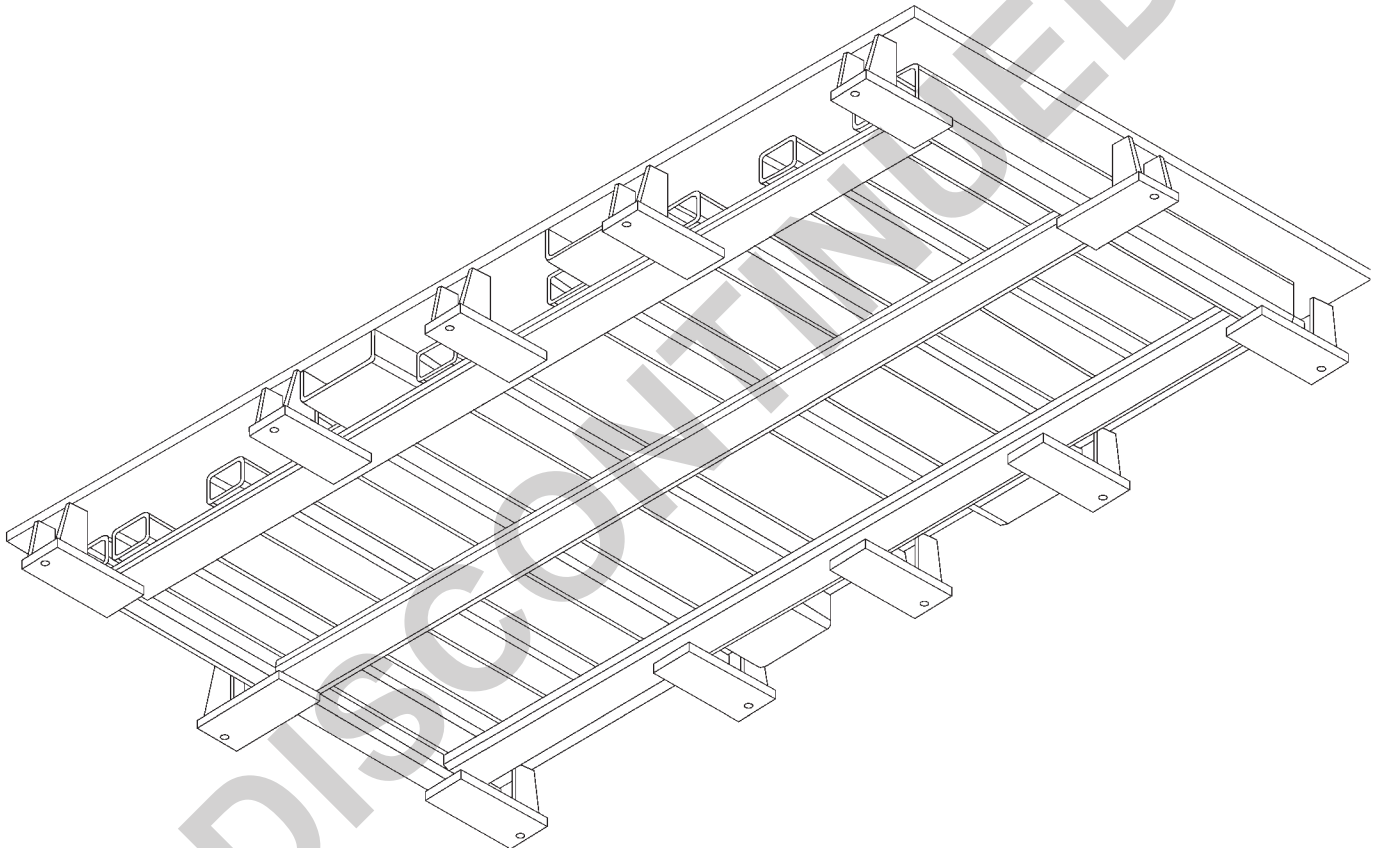

BASES ASB2424

Overall Base Thickness 210
Top Plate 2400 x 2400
Base Footprint 2530 x 2530
All seams completely welded. Stitch welding is not allowed.
Weight 2,440kg

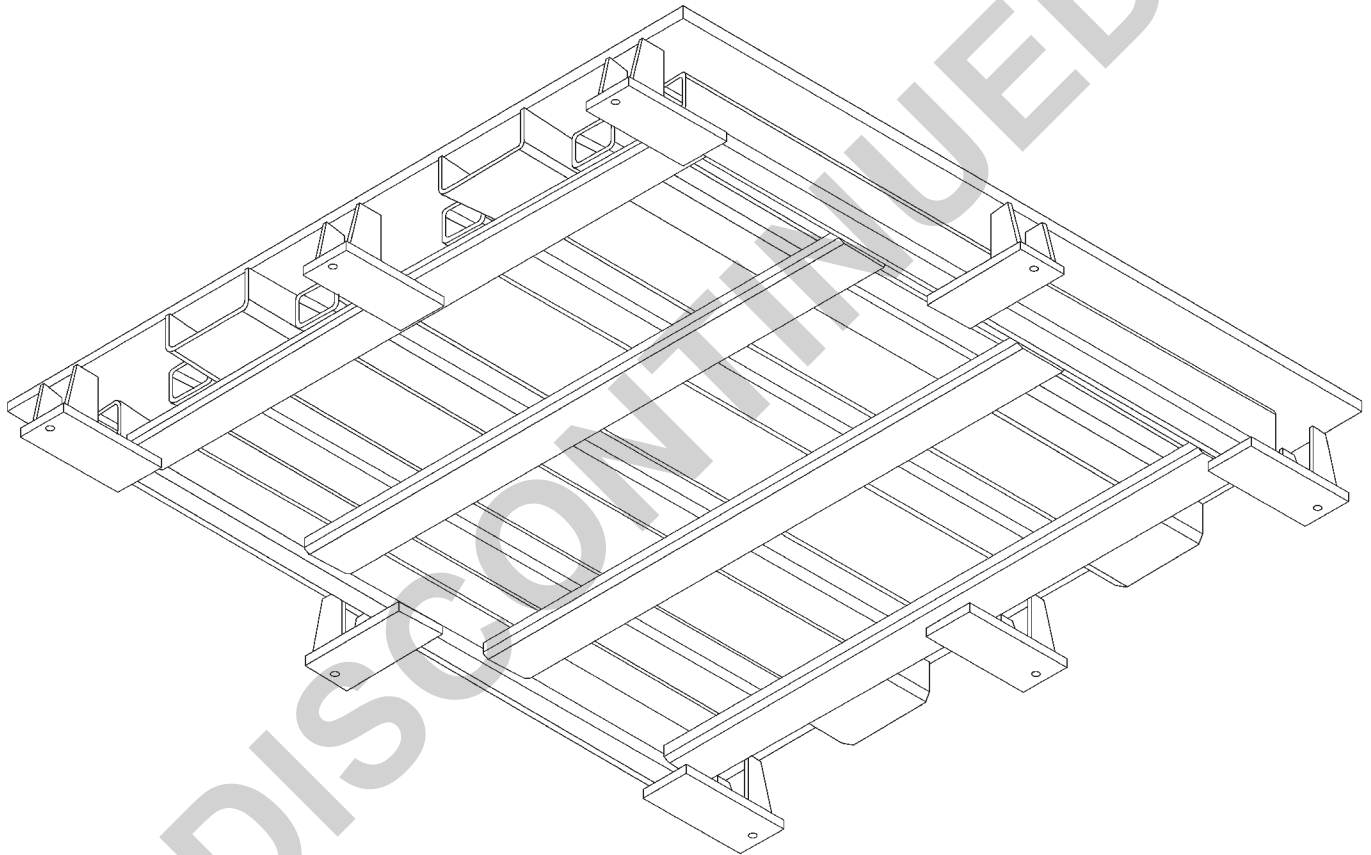

A

C

D

E

B

BASES ASB2430

A

Overall Base Thickness 210
Top Plate 2400 x 3000
Base Footprint 2530 x 3130
All seams completely welded. Stitch welding is not allowed.
Weight 3,039kg

C

D

E

B

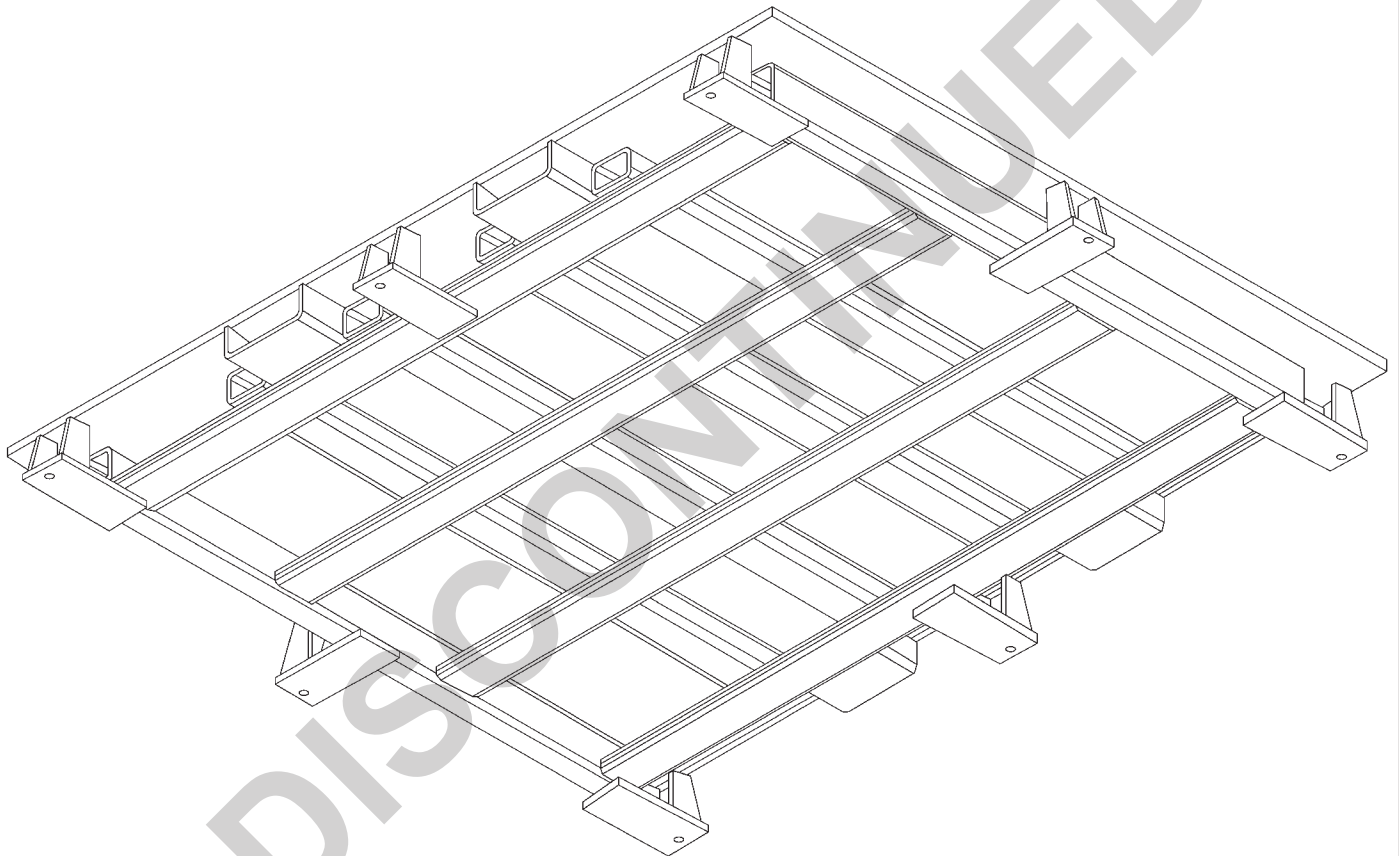

BASES ASB2436

Overall Base Thickness 210
Top Plate 2400 x 3600
Base Footprint 2530 x 3730
All seams completely welded. Stitch welding is not allowed.
Weight 3,713kg

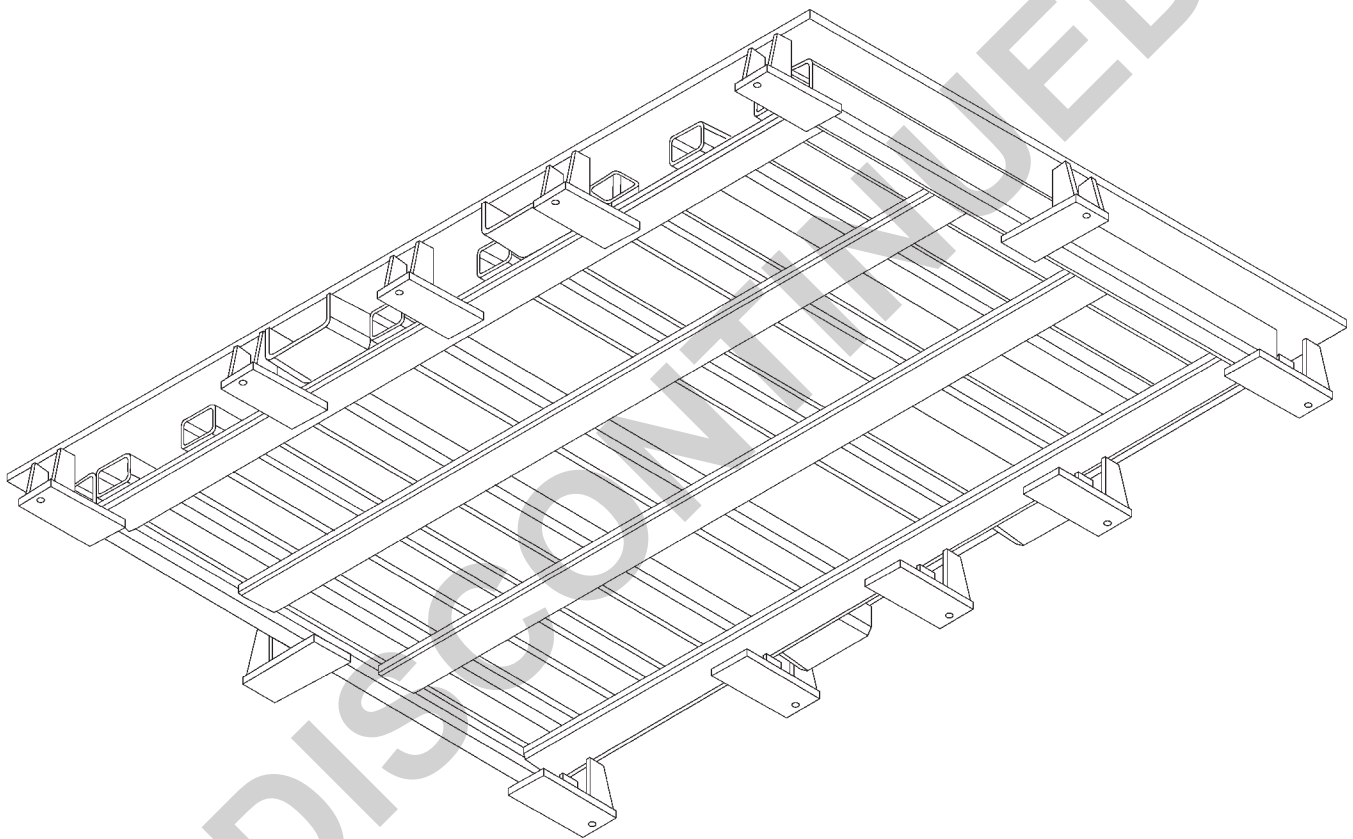

STANDARD BASE LEVELING METHOD #1

GLOBAL STANDARD COMPONENTS



Assembly

02/09/06

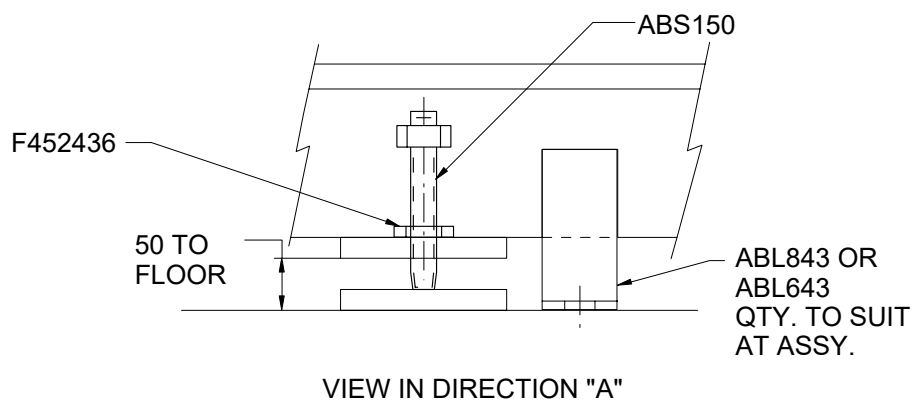
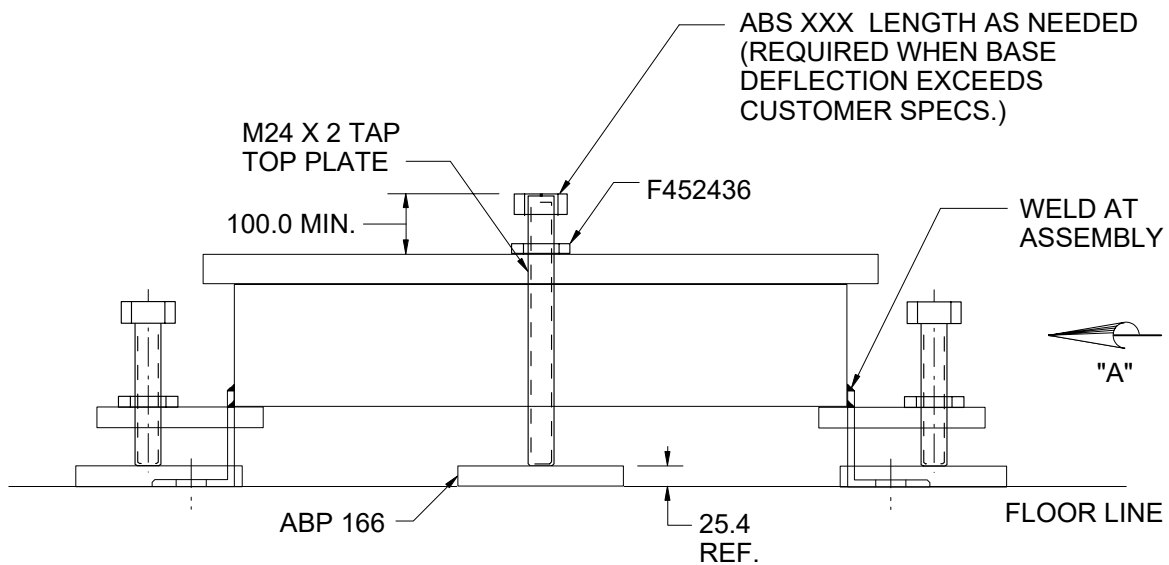

A

STANDARD BASE LEVELING METHOD #2

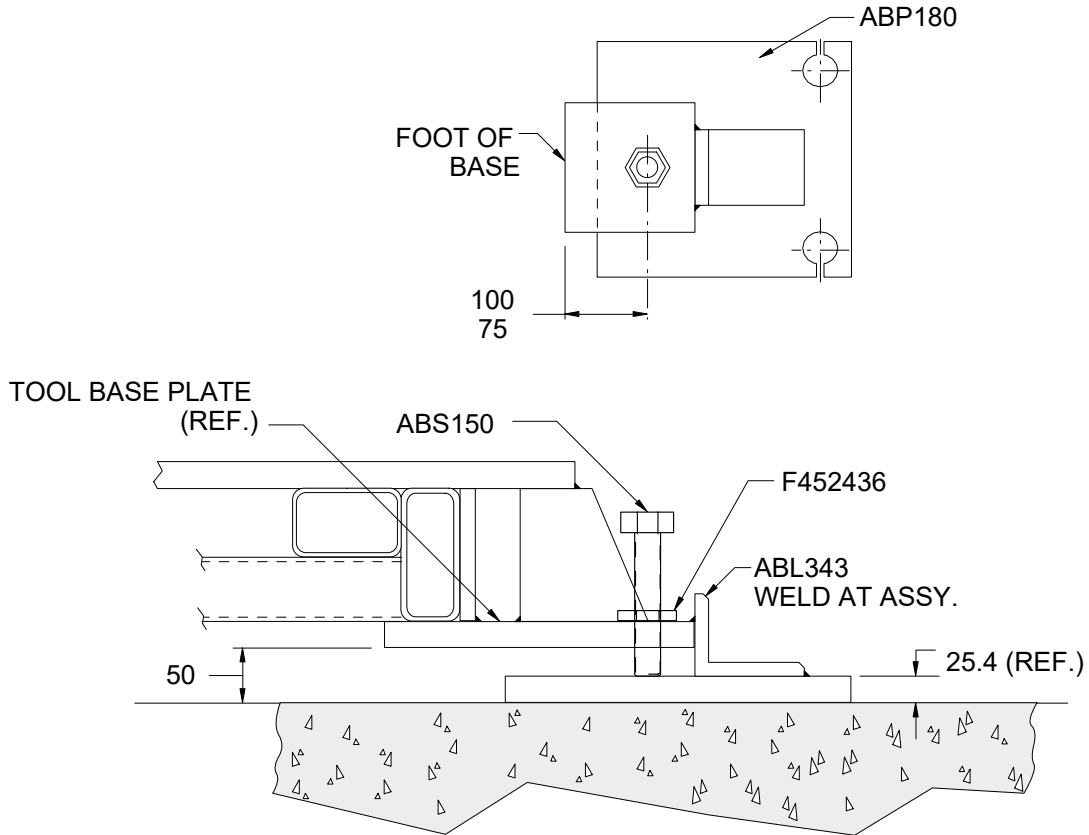

LEVELING METHOD #3 HEAVY FRAMES THAT NEED TO BE LEVELED

GLOBAL STANDARD COMPONENTS



Assembly

04/29/98

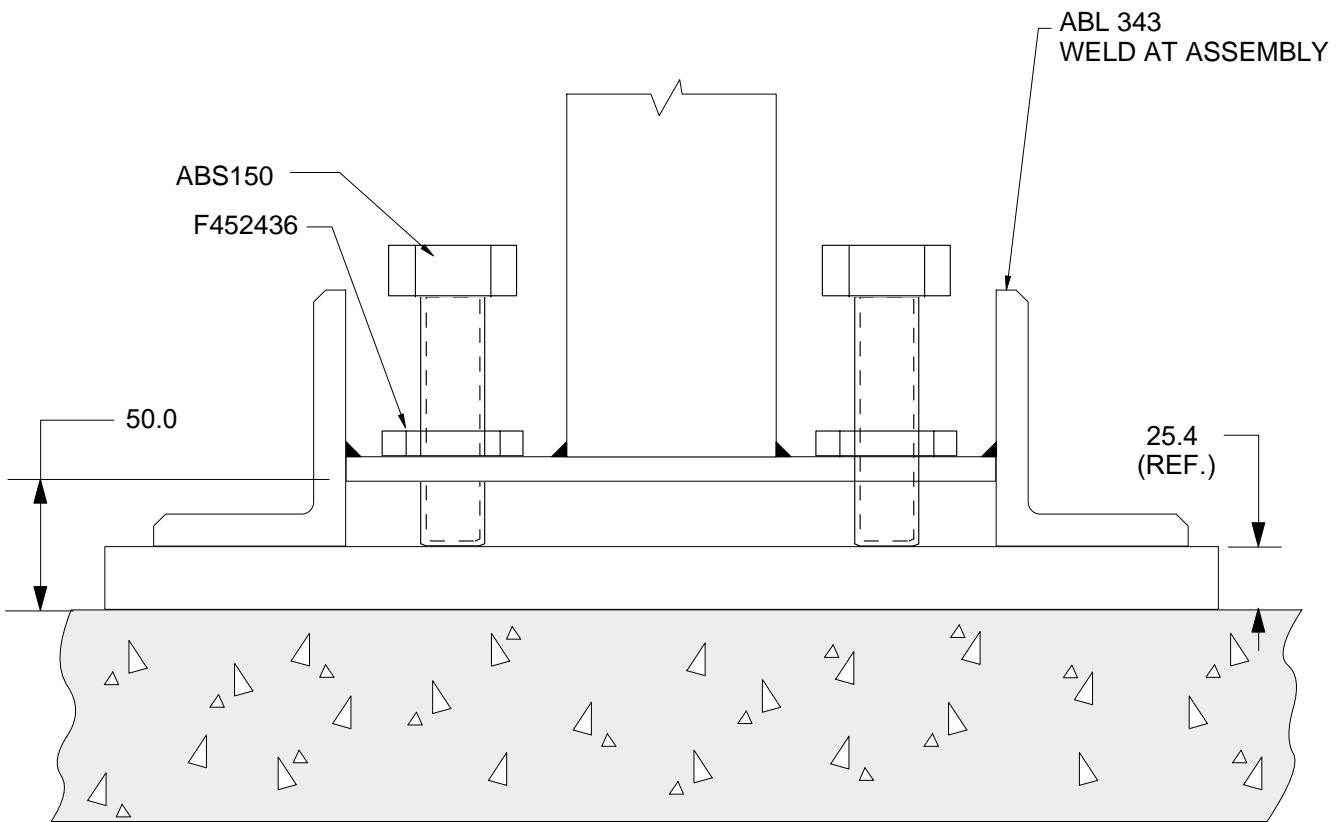

A

LEVELING METHOD #4 FRAMES THAT DO NOT NEED TO BE LEVELED

GLOBAL STANDARD COMPONENTS



Assembly

03/11/98

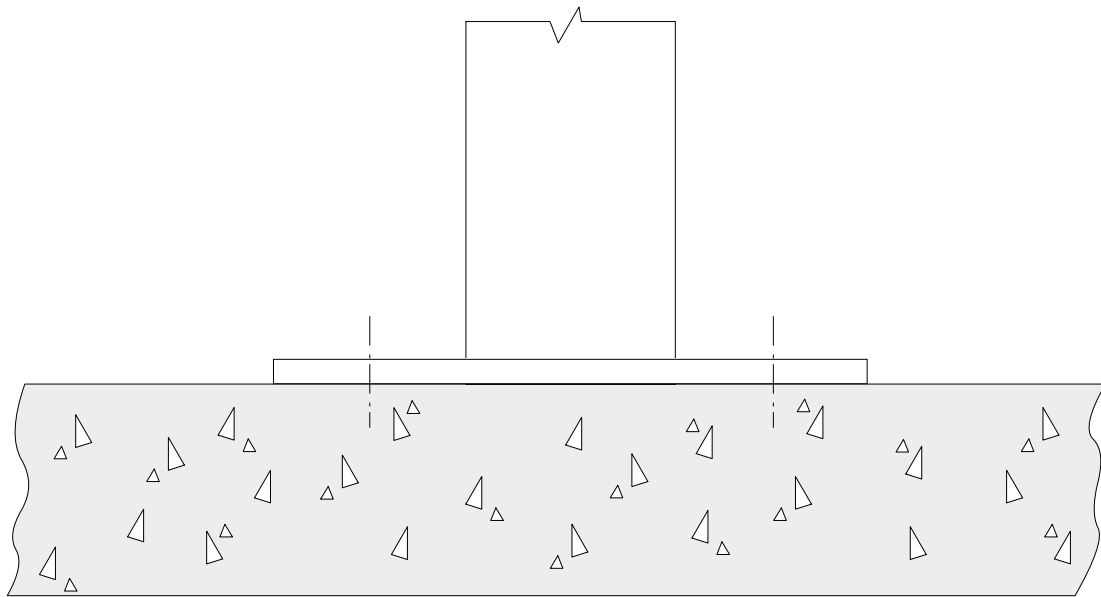

LEVELING METHOD #5 LIGHT FRAMES THAT NEED TO BE LEVELED

GLOBAL STANDARD COMPONENTS



Assembly

03/11/98

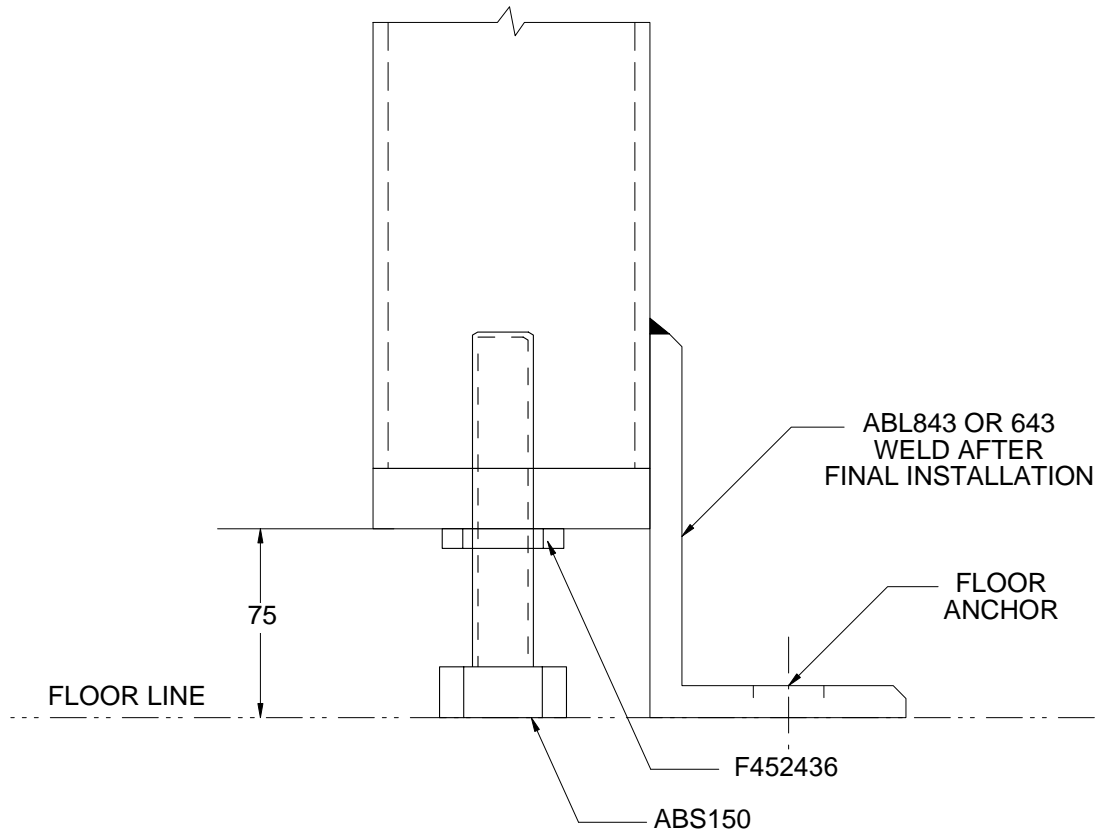

LEVELING METHOD #6 STANDARD ROBOT MOUNTING

GLOBAL STANDARD COMPONENTS



Assembly

02/13/08

USE WITH ARRXXX SERIES ROBOT RISERS, EVEN NUMBERS ONLY.
DO NOT USE WITH ARR031, ARR061, ARR091, ARR121, ARR151, OR ARR181.

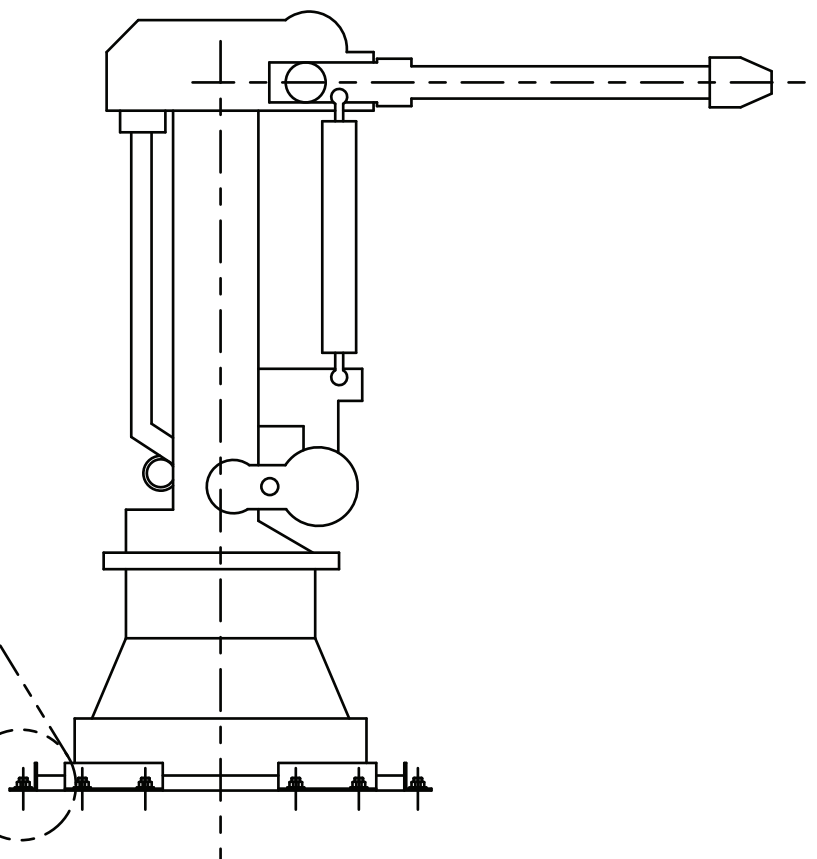
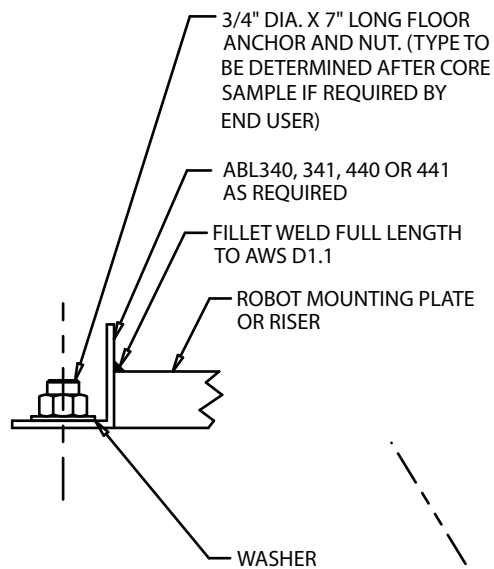
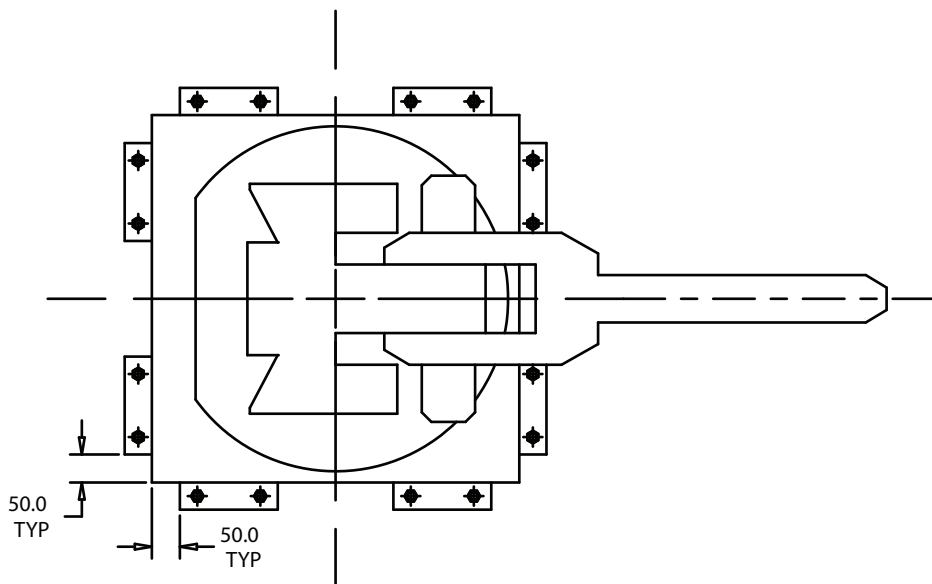

G

J
F

C

I
A
B

E

H
D

ANCHOR ANGLES

TOLERANCE:
 1 PLACE FABRICATION $\pm 1.5\text{MM}$

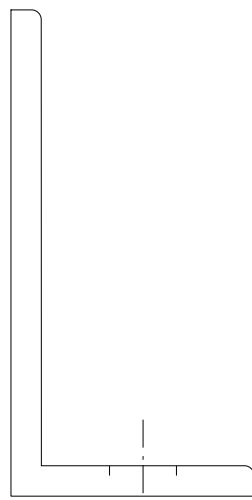
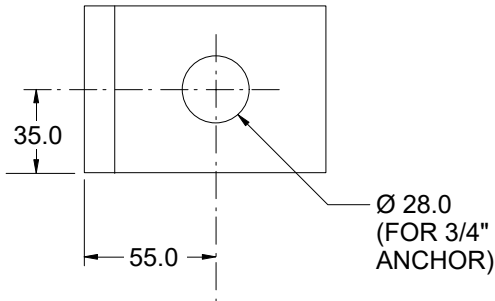

ABL843

MATERIAL: STL. ANGLE ASTM A-36
 8" X 4" X 1/2" X 70.0 mm LONG
 WEIGHT: 1.81kg

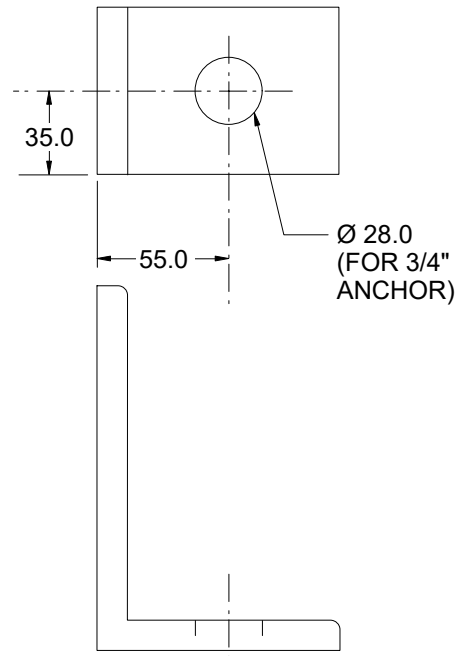

ABL643

MATERIAL: STL. ANGLE ASTM A-36
 6" X 4" X 1/2" X 70.0 mm LONG
 WEIGHT: 1.59kg

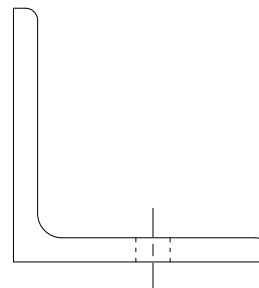
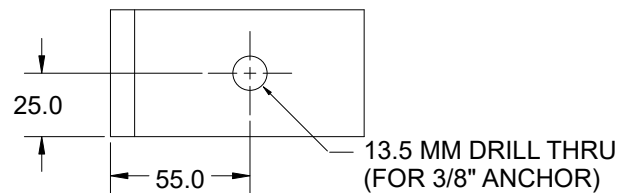

ABL443

MATERIAL: STL. ANGLE ASTM A-36
 4" X 4" X 3/8" X 50.0 mm LONG
 or 100mm X 100mm X 10mm X 50 mm LONG
 WEIGHT: 0.7kg

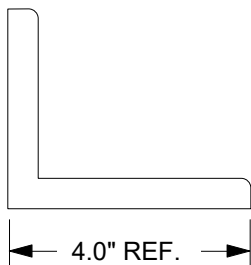

ABL343

MATERIAL: STL. ANGLE ASTM A-36
 4" X 3" X 1/2" X 75.0 mm LONG
 WEIGHT: 1.36kg

C

B

D

A

E

SEE PAGE B-1.1 FOR GLOBAL MATERIALS CHART

ANCHOR ANGLES

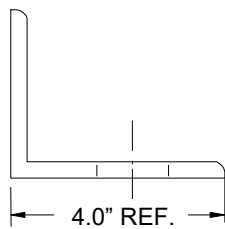
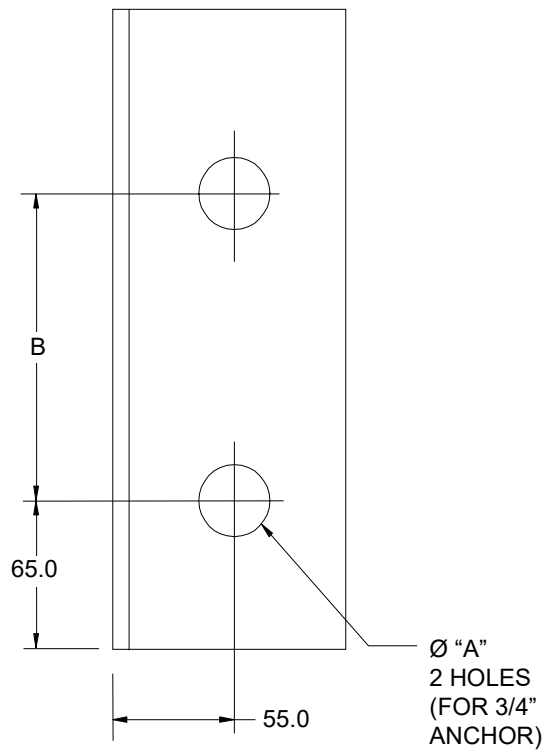

ABL340, ABL341
 MATERIAL: STL. ANG. ASTM A-36
 4" X 3" X 1/2" X C LONG
 or 100mm X 75mm X 12mm X C LONG

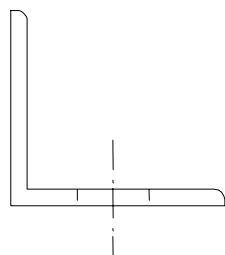

ABL440, ABL441
 MATERIAL: STL. ANG. ASTM A-36
 4" X 4" X 1/2" X C LONG
 or 100mm X 100mm X 12mm X C LONG

NAAMS CODE	A	B	C	STOCK / WEIGHT (kg)	
				INCH	METRIC
ABL340	25.0	260.0	390.0	6.4	6.8
ABL341	21.0	120.0	250.0	4.1	4.4
ABL440	25.0	260.0	390.0	7.4	6.8
ABL441	21.0	120.0	250.0	4.7	4.4

B

E

C

D

A

D

SEE PAGE B-1.1 FOR GLOBAL MATERIALS CHART

LEVELING FLOOR PLATES

ABP166

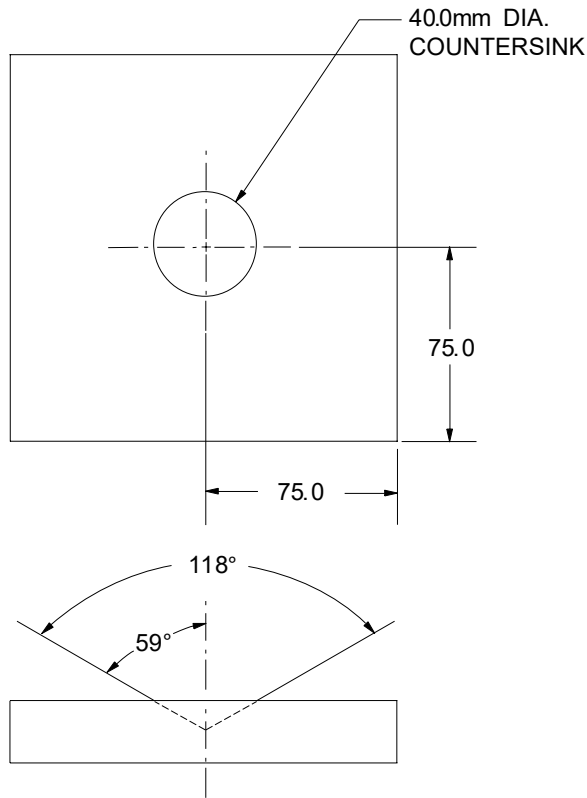

MATERIAL: 1" X 6" X 150.0 mm LONG
 S.A.E1020 H.R.S.
 Weight 4.54kg

ABP180

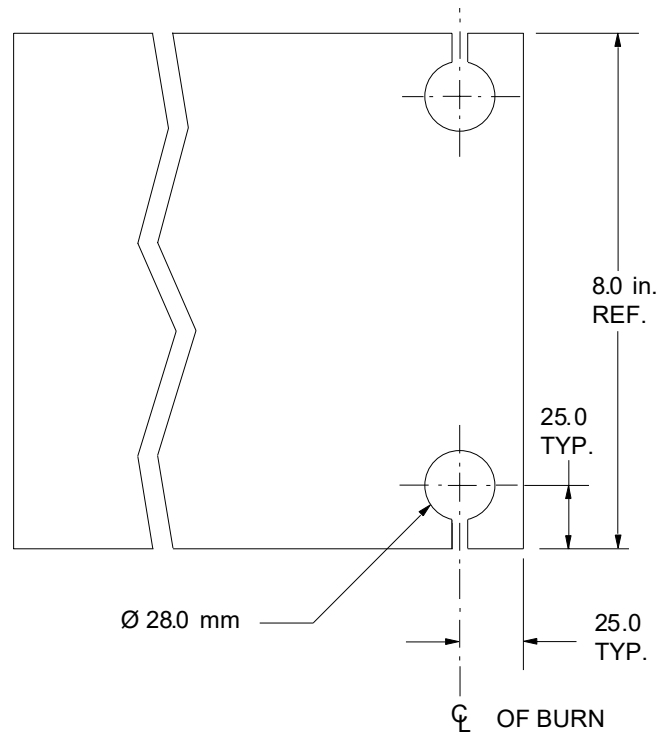

MATERIAL: 1" X 8" X 250.0 mm LONG
 S.A.E1020 H.R.S.
 Weight 9.98kg

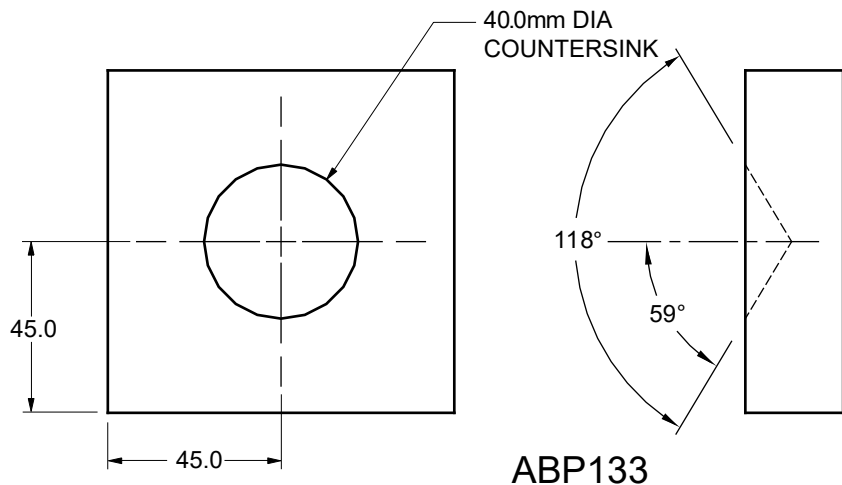

ABP133

MATERIAL: 1" X 3 1/2" X 90mm
 SAE 1020 H.R.S.
 Weight 1.54kg

SEE PAGE B-1.1 FOR GLOBAL MATERIALS CHART

A

B

C

D

LEVELING SCREW ASSEMBLIES

INTERIOR LEVELING SCREW ASSEMBLY

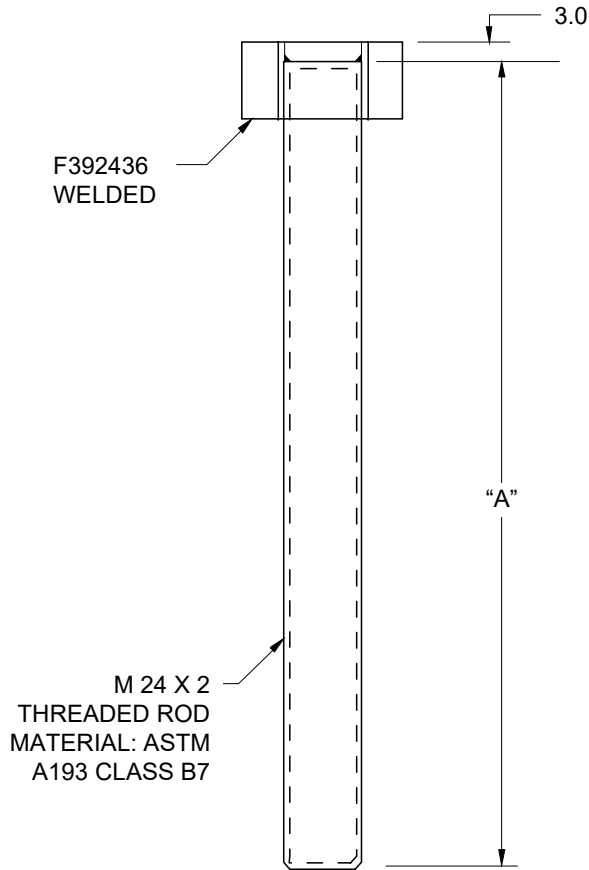

ABS150 PERIMETER LEVELING SCREW

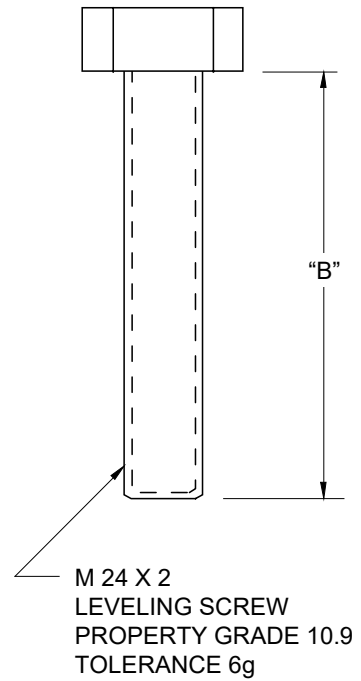

A

NAAMS CODE	SCREW LENGTH "A"
ABS250	250.0
ABS300	300.0
ABS350	350.0
ABS400	400.0
ABS450	450.0
ABS500	500.0

NAAMS CODE	DIM "B"	WT. kg
ABS100	100.0	0.43
ABS150	150.0	0.59

B

C

ROBOT RISERS

I

A

E

H

B

F

G

C

D

ATTACHING HOLES PER
ROBOT MANUFACTURER'S
SPECIFICATION

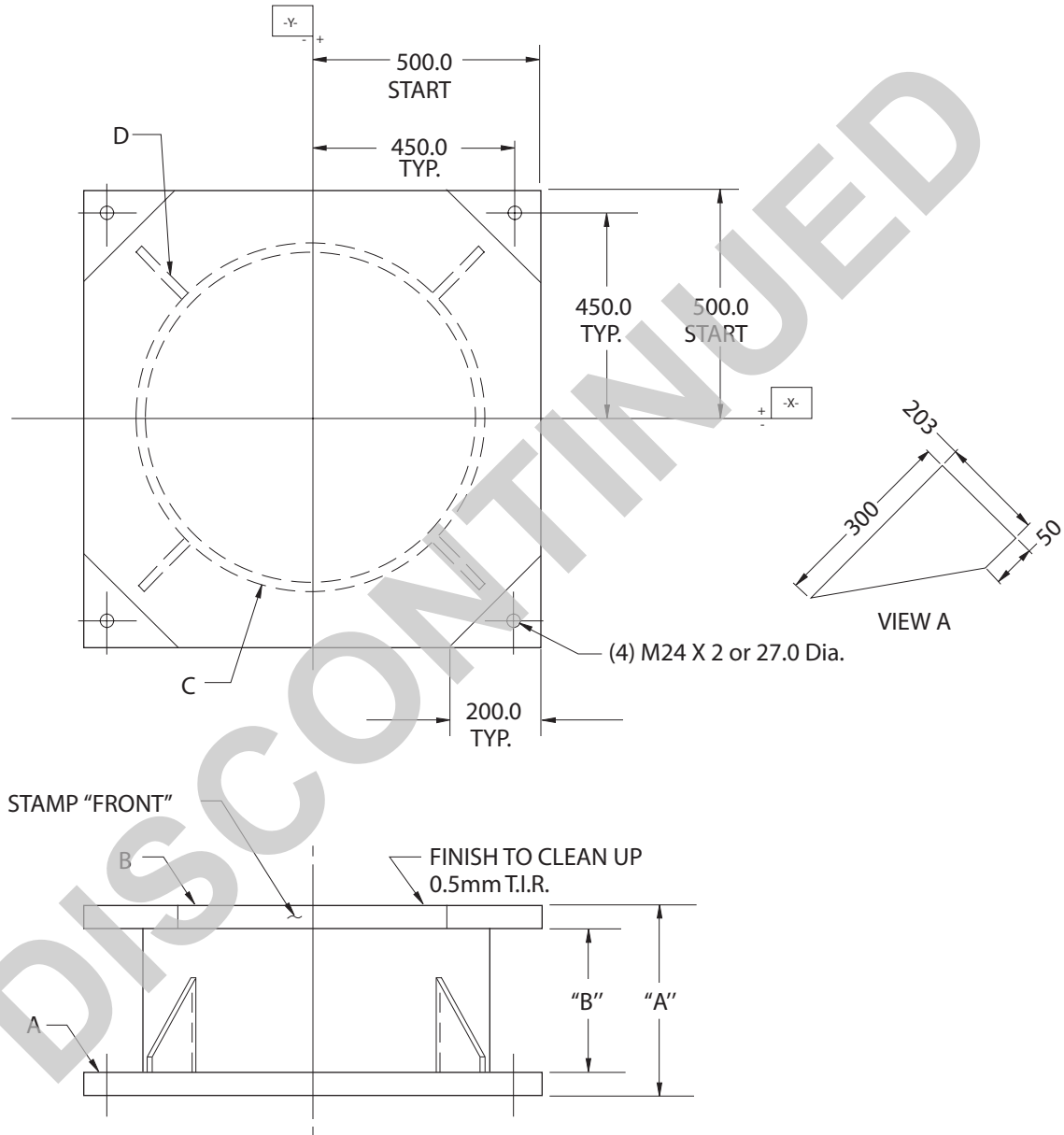

NOTES: SCRIBE CENTERLINE OF ROBOT ON SUB-DETAIL "A" (ALL FOUR SIDES)
SEE FOLLOWING PAGE FOR NAAMS CODE, "A" AND "B" DIMENSIONS.

- (A) 1 REQ'D ~ STL. PLATE ASTM A-36 ~ 1-3/4" X 1000mm X 1000mm
- (B) 1 REQ'D ~ STL. PLATE ASTM A-36 ~ 1-3/4" X 1000mm X 1000mm
- (C) 1 REQ'D ~ STL. TUB'G ASTM A-36 ~ 30" OD X 1/2" W/T X "B"
- (D) 2 REQ'D ~ S.A.E. 1020 H.R.S. ~ 1/2" X 8" X 350mm (1 MAKES 2) (USED IF "B" EXCEEDS 300mm)

SEE PAGE B-1.1 FOR GLOBAL MATERIALS CHART

ROBOT RISERS

F

NAAMS CODE	A±3	B REF	HOLE DETAIL	MOUNTING SYSTEM #	WEIGHT kg
ARR020	200	114	M24 X 2	6	734
ARR021	200	114	27.0 DIA.	7	734
ARR030	300	214	M24 X 2	6	749
ARR031	300	214	27.0 DIA.	7	749
ARR040	400	314	M24 X 2	6	771
ARR041	400	314	27.0 DIA.	7	771
ARR050	500	414	M24 X 2	6	790
ARR051	500	414	27.0 DIA.	7	790
ARR060	600	514	M24 X 2	6	808
ARR061	600	514	27.0 DIA.	7	808
ARR070	700	614	M24 X 2	6	825
ARR071	700	614	27.0 DIA.	7	825
ARR080	800	714	M24 X 2	6	842
ARR081	800	714	27.0 DIA.	7	842
ARR090	900	814	M24 X 2	6	860
ARR091	900	814	27.0 DIA.	7	860
ARR100	1000	914	M24 X 2	6	878
ARR101	1000	914	27.0 DIA.	7	878
ARR110	1100	1014	M24 X 2	6	896
ARR111	1100	1014	27.0 DIA.	7	896
ARR120	1200	1114	M24 X 2	6	914
ARR121	1200	1114	27.0 DIA.	7	914
ARR130	1300	1214	M24 X 2	6	932
ARR131	1300	1214	27.0 DIA.	7	932
ARR140	1400	1314	M24 X 2	6	955
ARR141	1400	1314	27.0 DIA.	7	955
ARR150	1500	1414	M24 X 2	6	973
ARR151	1500	1414	27.0 DIA.	7	973
ARR160	1600	1514	M24 X 2	6	991
ARR161	1600	1514	27.0 DIA.	7	991
ARR170	1700	1614	M24 X 2	6	1,010
ARR171	1700	1614	27.0 DIA.	7	1,010
ARR180	1800	1714	M24 X 2	6	1,028
ARR181	1800	1714	27.0 DIA.	7	1,028

A

B

C

D

E

SEE DRAWING ON PRECEDING PAGE

ANCHORING METHOD #7 STANDARD ROBOT MOUNTING

USE ONLY WITH ROBOT RISERS ARR031, ARR061, ARR091, ARR121, ARR151 AND ARR181.
USE FOUR (4) ANCHOR PLATES IN CONJUNCTION WITH CORNER HOLES ON RISER, FOR A TOTAL
OF EIGHT ANCHOR POINTS.

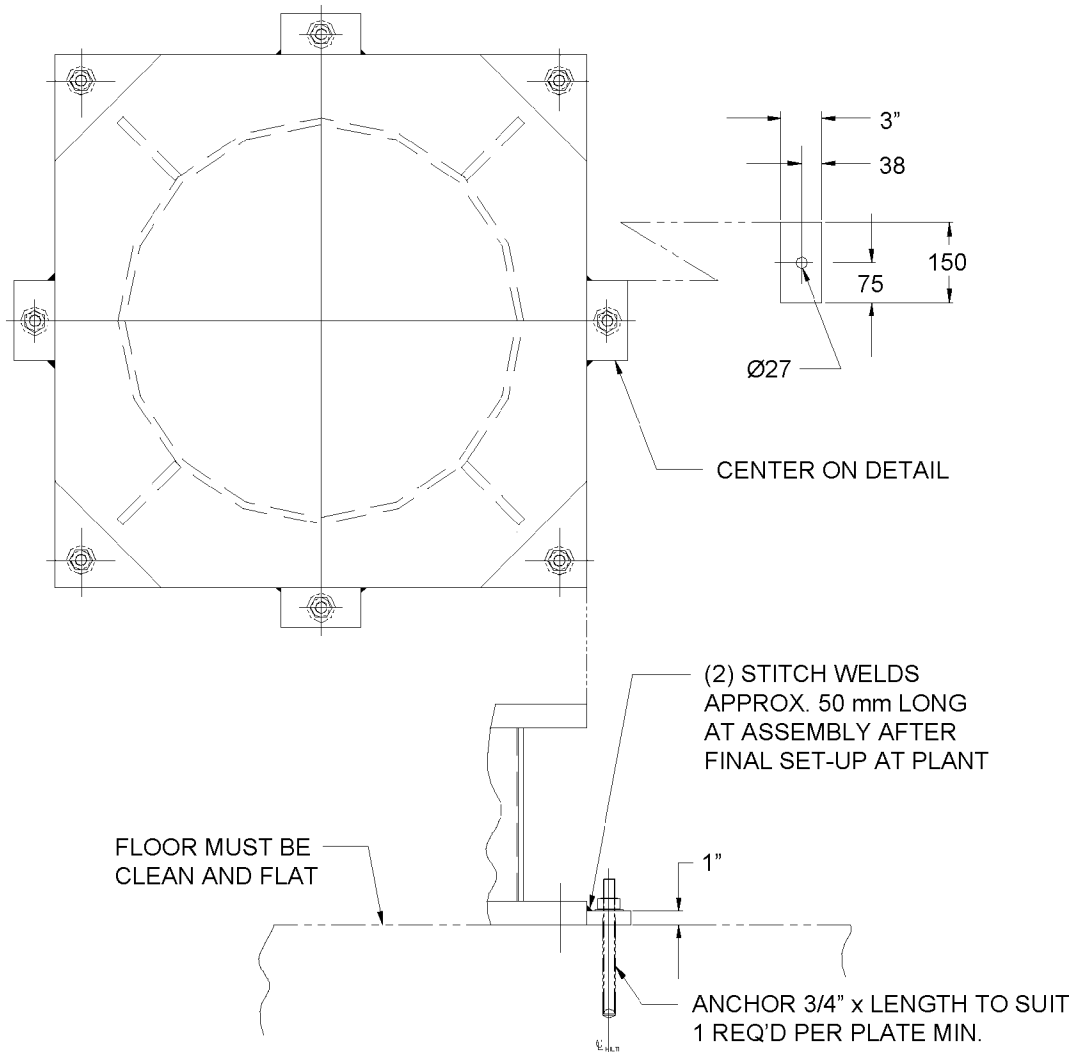

LIGHTWEIGHT BASES

GLOBAL STANDARD COMPONENTS



Assembly

04/15/20

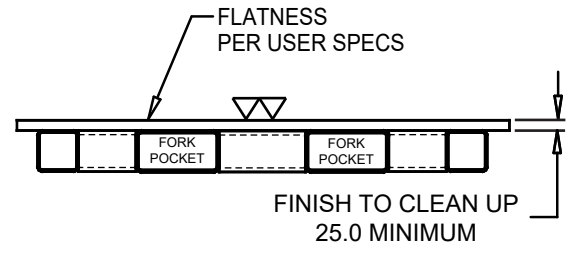
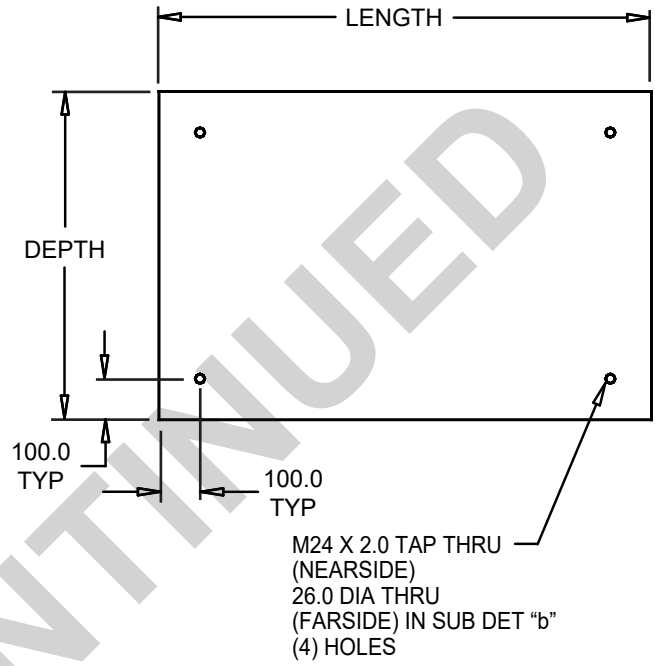
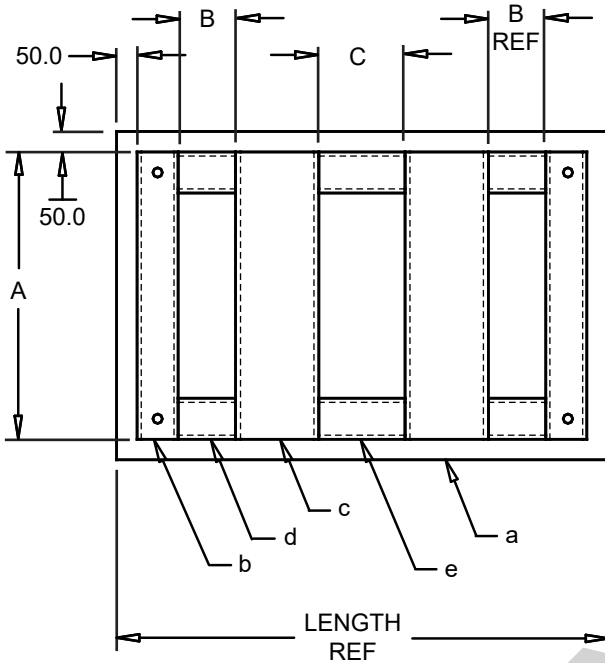

TOLERANCES:
 1 PLACE MACHINING ± 0.3
 1 PLACE FABRICATION ± 1.5

THIS STANDARD IS FOR THE BASE ONLY

THE HOLES FOR UNITS TO BE ADDED ON A DETAIL SHEET

PAINT SPEC: PER USER SPECIFICATIONS

STRESS RELIEVE

ALL SEAMS TO BE COMPLETELY WELDED

STITCH WELDING IS NOT ALLOWED

INCH DIMENSION STOCK

a	1 - STL PLT	ASTM A-36	1 1/4 X "DEPTH" mm X "LENGTH" mm
b	2 - STL TBG	ASTM A-500 GRADE B	4 X 4 X 1/4 WT X "A" mm
c	2 - STL TBG	ASTM A-500 GRADE B	8 X 4 X 1/4 WT X "A" mm
d	4 - STL TBG	ASTM A-500 GRADE B	4 X 4 X 1/4 WT X "B" mm
e	2 - STL TBG	ASTM A-500 GRADE B	4 X 4 X 1/4 WT X "C" mm

SEE PAGE B-1.1 FOR GLOBAL MATERIALS CHART

LIGHTWEIGHT BASES

GLOBAL STANDARD COMPONENTS



Assembly

04/15/20

NAAMS CODE	DEPTH	LENGTH	A	B	C	WEIGHT kg
ASB0512L	500	1200	400.0	140.0	210.0	170
ASB0612L	600	1200	500.0	140.0	210.0	210
ASB0712L	700	1200	600.0	140.0	210.0	250
ASB0812L	800	1200	700.0	140.0	210.0	290
ASB0912L	900	1200	800.0	140.0	210.0	330
ASB1012L	1000	1200	900.0	140.0	210.0	370
ASB1112L	1100	1200	1000.0	140.0	210.0	410
ASB1212L	1200	1200	1100.0	140.0	210.0	450
ASB1312L	1300	1200	1200.0	140.0	210.0	490
ASB1412L	1400	1200	1300.0	140.0	210.0	530
ASB1512L	1500	1200	1400.0	140.0	210.0	570
ASB1612L	1600	1200	1500.0	140.0	210.0	610
ASB1712L	1700	1200	1600.0	140.0	210.0	650
ASB1812L	1800	1200	1700.0	140.0	210.0	690

NAAMS CODE	DEPTH	LENGTH	A	B	C	WEIGHT kg
ASB0515L	500	1500	400.0	215.0	360.0	215
ASB0615L	600	1500	500.0	215.0	360.0	255
ASB0715L	700	1500	600.0	215.0	360.0	295
ASB0815L	800	1500	700.0	215.0	360.0	335
ASB0915L	900	1500	800.0	215.0	360.0	375
ASB1015L	1000	1500	900.0	215.0	360.0	415
ASB1115L	1100	1500	1000.0	215.0	360.0	455
ASB1215L	1200	1500	1100.0	215.0	360.0	495
ASB1315L	1300	1500	1200.0	215.0	360.0	535
ASB1415L	1400	1500	1300.0	215.0	360.0	575
ASB1515L	1500	1500	1400.0	215.0	360.0	615
ASB1615L	1600	1500	1500.0	215.0	360.0	655
ASB1715L	1700	1500	1600.0	215.0	360.0	695
ASB1815L	1800	1500	1700.0	215.0	360.0	735

NAAMS CODE	DEPTH	LENGTH	A	B	C	WEIGHT kg
ASB0513L	500	1300	400.0	165.0	260.0	185
ASB0613L	600	1300	500.0	165.0	260.0	225
ASB0713L	700	1300	600.0	165.0	260.0	265
ASB0813L	800	1300	700.0	165.0	260.0	305
ASB0913L	900	1300	800.0	165.0	260.0	345
ASB1013L	1000	1300	900.0	165.0	260.0	385
ASB1113L	1100	1300	1000.0	165.0	260.0	425
ASB1213L	1200	1300	1100.0	165.0	260.0	465
ASB1313L	1300	1300	1200.0	165.0	260.0	505
ASB1413L	1400	1300	1300.0	165.0	260.0	545
ASB1513L	1500	1300	1400.0	165.0	260.0	585
ASB1613L	1600	1300	1500.0	165.0	260.0	625
ASB1713L	1700	1300	1600.0	165.0	260.0	665
ASB1813L	1800	1300	1700.0	165.0	260.0	705

NAAMS CODE	DEPTH	LENGTH	A	B	C	WEIGHT kg
ASB0516L	500	1600	400.0	240.0	410.0	230
ASB0616L	600	1600	500.0	240.0	410.0	270
ASB0716L	700	1600	600.0	240.0	410.0	310
ASB0816L	800	1600	700.0	240.0	410.0	350
ASB0916L	900	1600	800.0	240.0	410.0	390
ASB1016L	1000	1600	900.0	240.0	410.0	430
ASB1116L	1100	1600	1000.0	240.0	410.0	470
ASB1216L	1200	1600	1100.0	240.0	410.0	510
ASB1316L	1300	1600	1200.0	240.0	410.0	550
ASB1416L	1400	1600	1300.0	240.0	410.0	590
ASB1516L	1500	1600	1400.0	240.0	410.0	630
ASB1616L	1600	1600	1500.0	240.0	410.0	670
ASB1716L	1700	1600	1600.0	240.0	410.0	710
ASB1816L	1800	1600	1700.0	240.0	410.0	750

NAAMS CODE	DEPTH	LENGTH	A	B	C	WEIGHT kg
ASB0514L	500	1400	400.0	190.0	310.0	200
ASB0614L	600	1400	500.0	190.0	310.0	240
ASB0714L	700	1400	600.0	190.0	310.0	280
ASB0814L	800	1400	700.0	190.0	310.0	320
ASB0914L	900	1400	800.0	190.0	310.0	360
ASB1014L	1000	1400	900.0	190.0	310.0	400
ASB1114L	1100	1400	1000.0	190.0	310.0	440
ASB1214L	1200	1400	1100.0	190.0	310.0	480
ASB1314L	1300	1400	1200.0	190.0	310.0	520
ASB1414L	1400	1400	1300.0	190.0	310.0	560
ASB1514L	1500	1400	1400.0	190.0	310.0	600
ASB1614L	1600	1400	1500.0	190.0	310.0	640
ASB1714L	1700	1400	1600.0	190.0	310.0	680
ASB1814L	1800	1400	1700.0	190.0	310.0	720

NAAMS CODE	DEPTH	LENGTH	A	B	C	WEIGHT kg
ASB0517L	500	1700	400.0	265.0	460.0	245
ASB0617L	600	1700	500.0	265.0	460.0	285
ASB0717L	700	1700	600.0	265.0	460.0	325
ASB0817L	800	1700	700.0	265.0	460.0	365
ASB0917L	900	1700	800.0	265.0	460.0	405
ASB1017L	1000	1700	900.0	265.0	460.0	445
ASB1117L	1100	1700	1000.0	265.0	460.0	485
ASB1217L	1200	1700	1100.0	265.0	460.0	525
ASB1317L	1300	1700	1200.0	265.0	460.0	565
ASB1417L	1400	1700	1300.0	265.0	460.0	605
ASB1517L	1500	1700	1400.0	265.0	460.0	645
ASB1617L	1600	1700	1500.0	265.0	460.0	685
ASB1717L	1700	1700	1600.0	265.0	460.0	725
ASB1817L	1800	1700	1700.0	265.0	460.0	765

C

B

A

LIGHTWEIGHT BASES

GLOBAL STANDARD COMPONENTS



Assembly

04/15/20

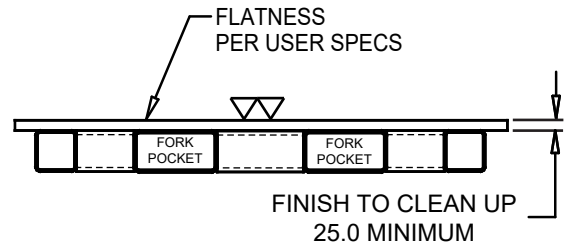
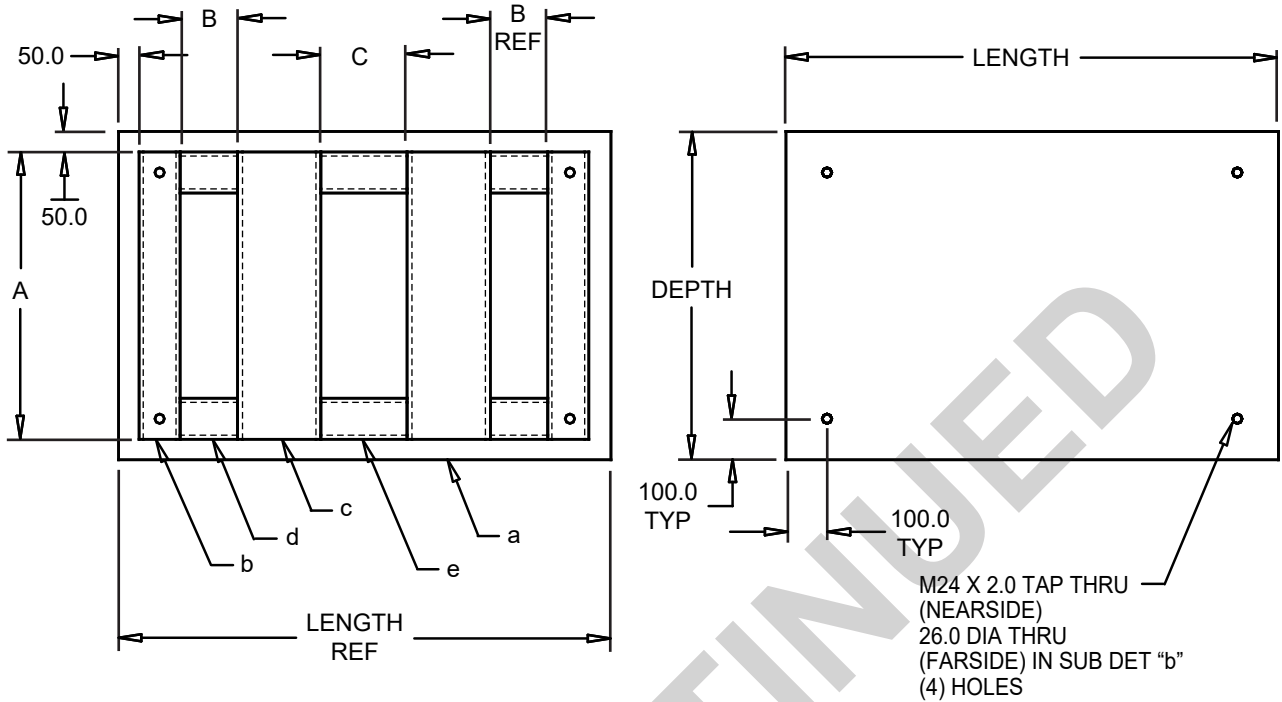

METRIC STOCK OPTION 1

a	1 - STL PLT	ASTM A-36	30 X "DEPTH" X "LENGTH"
b	2 - STL TBG	ASTM A-500 GRADE B	100 X 100 X 6 WT X "A"
c	2 - STL TBG	ASTM A-500 GRADE B	200 X 100 X 6 WT X "A"
d	4 - STL TBG	ASTM A-500 GRADE B	100 X 100 X 6 WT X "B"
e	2 - STL TBG	ASTM A-500 GRADE B	100 X 100 X 6 WT X "C"

OPTION 2

a	1 - STL PLT	ASTM A-36	30 X "DEPTH" X "LENGTH"
b	2 - STL TBG	ASTM A-500 GRADE B	100 X 100 X 6 WT X "A"
c	2 - STL PLT	ASTM A36	6 X 410 X "A"
d	4 - STL TBG	ASTM A-500 GRADE B	100 X 100 X 6 WT X "B"
e	2 - STL TBG	ASTM A-500 GRADE B	100 X 100 X 6 WT X "C"

OPTION 2 IS FOR USE WHERE STEEL TUBING IS DIFFICULT TO FIND

SEE PAGE B-1.1 FOR GLOBAL MATERIALS CHART

TOLERANCES:

- 1 PLACE MACHINING ± 0.3
- 1 PLACE FABRICATION ± 1.5

THIS STANDARD IS FOR THE BASE ONLY

THE HOLES FOR UNITS TO BE ADDED ON A DETAIL SHEET

PAINT SPEC: PER USER SPECIFICATIONS

STRESS RELIEVE

ALL SEAMS TO BE COMPLETELY WELDED

STITCH WELDING IS NOT ALLOWED

B

A

LIGHTWEIGHT BASES

GLOBAL STANDARD COMPONENTS



Assembly

04/15/20

A

NAAMS CODE	DEPTH	LENGTH	A	B	C	WEIGHT kg
ASB0512LM	500	1200	400.0	140.0	210.0	170
ASB0612LM	600	1200	500.0	140.0	210.0	210
ASB0712LM	700	1200	600.0	140.0	210.0	250
ASB0812LM	800	1200	700.0	140.0	210.0	290
ASB0912LM	900	1200	800.0	140.0	210.0	330
ASB1012LM	1000	1200	900.0	140.0	210.0	370
ASB1112LM	1100	1200	1000.0	140.0	210.0	410
ASB1212LM	1200	1200	1100.0	140.0	210.0	450
ASB1312LM	1300	1200	1200.0	140.0	210.0	490
ASB1412LM	1400	1200	1300.0	140.0	210.0	530
ASB1512LM	1500	1200	1400.0	140.0	210.0	570
ASB1612LM	1600	1200	1500.0	140.0	210.0	610
ASB1712LM	1700	1200	1600.0	140.0	210.0	650
ASB1812LM	1800	1200	1700.0	140.0	210.0	690

NAAMS CODE	DEPTH	LENGTH	A	B	C	WEIGHT kg
ASB0515LM	500	1500	400.0	215.0	360.0	215
ASB0615LM	600	1500	500.0	215.0	360.0	255
ASB0715LM	700	1500	600.0	215.0	360.0	295
ASB0815LM	800	1500	700.0	215.0	360.0	335
ASB0915LM	900	1500	800.0	215.0	360.0	375
ASB1015LM	1000	1500	900.0	215.0	360.0	415
ASB1115LM	1100	1500	1000.0	215.0	360.0	455
ASB1215LM	1200	1500	1100.0	215.0	360.0	495
ASB1315LM	1300	1500	1200.0	215.0	360.0	535
ASB1415LM	1400	1500	1300.0	215.0	360.0	575
ASB1515LM	1500	1500	1400.0	215.0	360.0	615
ASB1615LM	1600	1500	1500.0	215.0	360.0	655
ASB1715LM	1700	1500	1600.0	215.0	360.0	695
ASB1815LM	1800	1500	1700.0	215.0	360.0	735

NAAMS CODE	DEPTH	LENGTH	A	B	C	WEIGHT kg
ASB0513LM	500	1300	400.0	165.0	260.0	185
ASB0613LM	600	1300	500.0	165.0	260.0	225
ASB0713LM	700	1300	600.0	165.0	260.0	265
ASB0813LM	800	1300	700.0	165.0	260.0	305
ASB0913LM	900	1300	800.0	165.0	260.0	345
ASB1013LM	1000	1300	900.0	165.0	260.0	385
ASB1113LM	1100	1300	1000.0	165.0	260.0	425
ASB1213LM	1200	1300	1100.0	165.0	260.0	465
ASB1313LM	1300	1300	1200.0	165.0	260.0	505
ASB1413LM	1400	1300	1300.0	165.0	260.0	545
ASB1513LM	1500	1300	1400.0	165.0	260.0	585
ASB1613LM	1600	1300	1500.0	165.0	260.0	625
ASB1713LM	1700	1300	1600.0	165.0	260.0	665
ASB1813LM	1800	1300	1700.0	165.0	260.0	705

NAAMS CODE	DEPTH	LENGTH	A	B	C	WEIGHT kg
ASB0516LM	500	1600	400.0	240.0	410.0	230
ASB0616LM	600	1600	500.0	240.0	410.0	270
ASB0716LM	700	1600	600.0	240.0	410.0	310
ASB0816LM	800	1600	700.0	240.0	410.0	350
ASB0916LM	900	1600	800.0	240.0	410.0	390
ASB1016LM	1000	1600	900.0	240.0	410.0	430
ASB1116LM	1100	1600	1000.0	240.0	410.0	470
ASB1216LM	1200	1600	1100.0	240.0	410.0	510
ASB1316LM	1300	1600	1200.0	240.0	410.0	550
ASB1416LM	1400	1600	1300.0	240.0	410.0	590
ASB1516LM	1500	1600	1400.0	240.0	410.0	630
ASB1616LM	1600	1600	1500.0	240.0	410.0	670
ASB1716LM	1700	1600	1600.0	240.0	410.0	710
ASB1816LM	1800	1600	1700.0	240.0	410.0	750

NAAMS CODE	DEPTH	LENGTH	A	B	C	WEIGHT kg
ASB0514LM	500	1400	400.0	190.0	310.0	200
ASB0614LM	600	1400	500.0	190.0	310.0	240
ASB0714LM	700	1400	600.0	190.0	310.0	280
ASB0814LM	800	1400	700.0	190.0	310.0	320
ASB0914LM	900	1400	800.0	190.0	310.0	360
ASB1014LM	1000	1400	900.0	190.0	310.0	400
ASB1114LM	1100	1400	1000.0	190.0	310.0	440
ASB1214LM	1200	1400	1100.0	190.0	310.0	480
ASB1314LM	1300	1400	1200.0	190.0	310.0	520
ASB1414LM	1400	1400	1300.0	190.0	310.0	560
ASB1514LM	1500	1400	1400.0	190.0	310.0	600
ASB1614LM	1600	1400	1500.0	190.0	310.0	640
ASB1714LM	1700	1400	1600.0	190.0	310.0	680
ASB1814LM	1800	1400	1700.0	190.0	310.0	720

NAAMS CODE	DEPTH	LENGTH	A	B	C	WEIGHT kg
ASB0517LM	500	1700	400.0	265.0	460.0	245
ASB0617LM	600	1700	500.0	265.0	460.0	285
ASB0717LM	700	1700	600.0	265.0	460.0	325
ASB0817LM	800	1700	700.0	265.0	460.0	365
ASB0917LM	900	1700	800.0	265.0	460.0	405
ASB1017LM	1000	1700	900.0	265.0	460.0	445
ASB1117LM	1100	1700	1000.0	265.0	460.0	485
ASB1217LM	1200	1700	1100.0	265.0	460.0	525
ASB1317LM	1300	1700	1200.0	265.0	460.0	565
ASB1417LM	1400	1700	1300.0	265.0	460.0	605
ASB1517LM	1500	1700	1400.0	265.0	460.0	645
ASB1617LM	1600	1700	1500.0	265.0	460.0	685
ASB1717LM	1700	1700	1600.0	265.0	460.0	725
ASB1817LM	1800	1700	1700.0	265.0	460.0	765

LIGHTWEIGHT BASES INSTALLATION

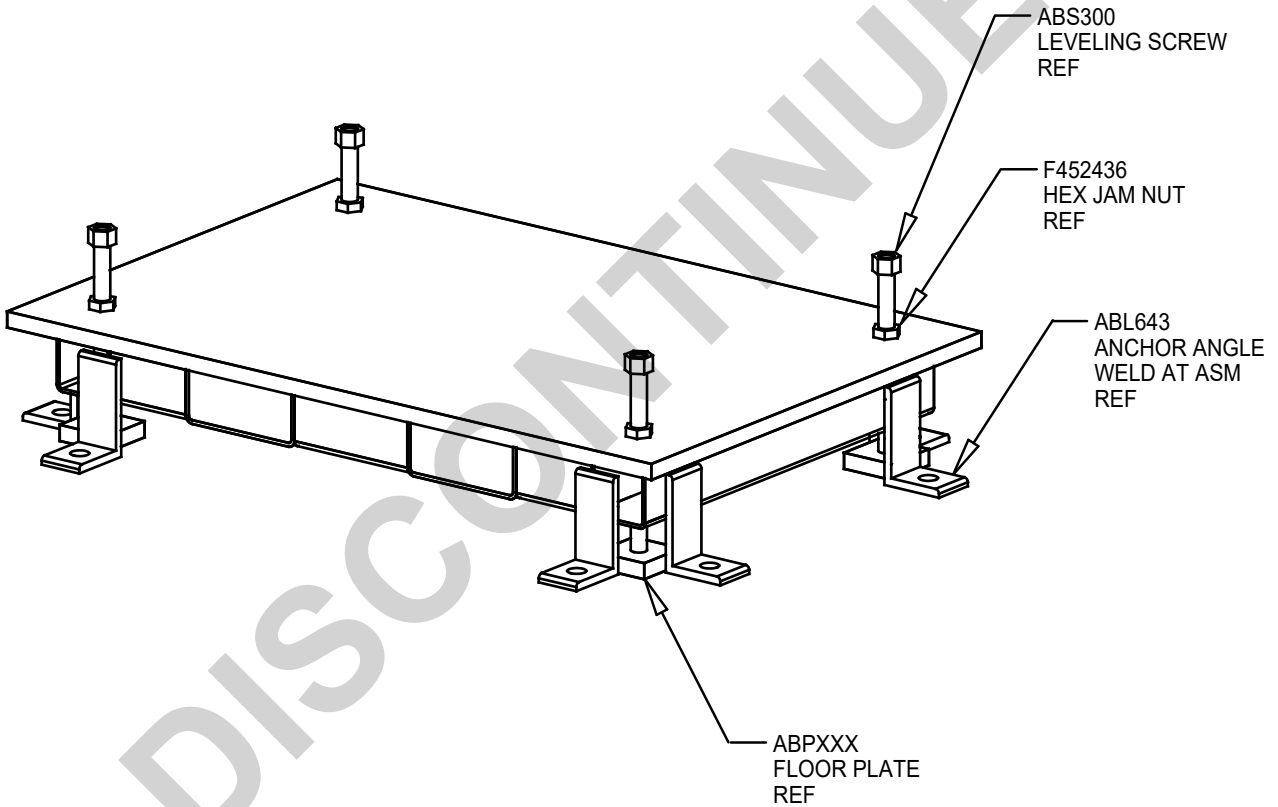

A

ROBOT RISER

400kg / 500kg

ATTACHING HOLES PER
 ROBOT MANUFACTURERS
 SPECIFICATION

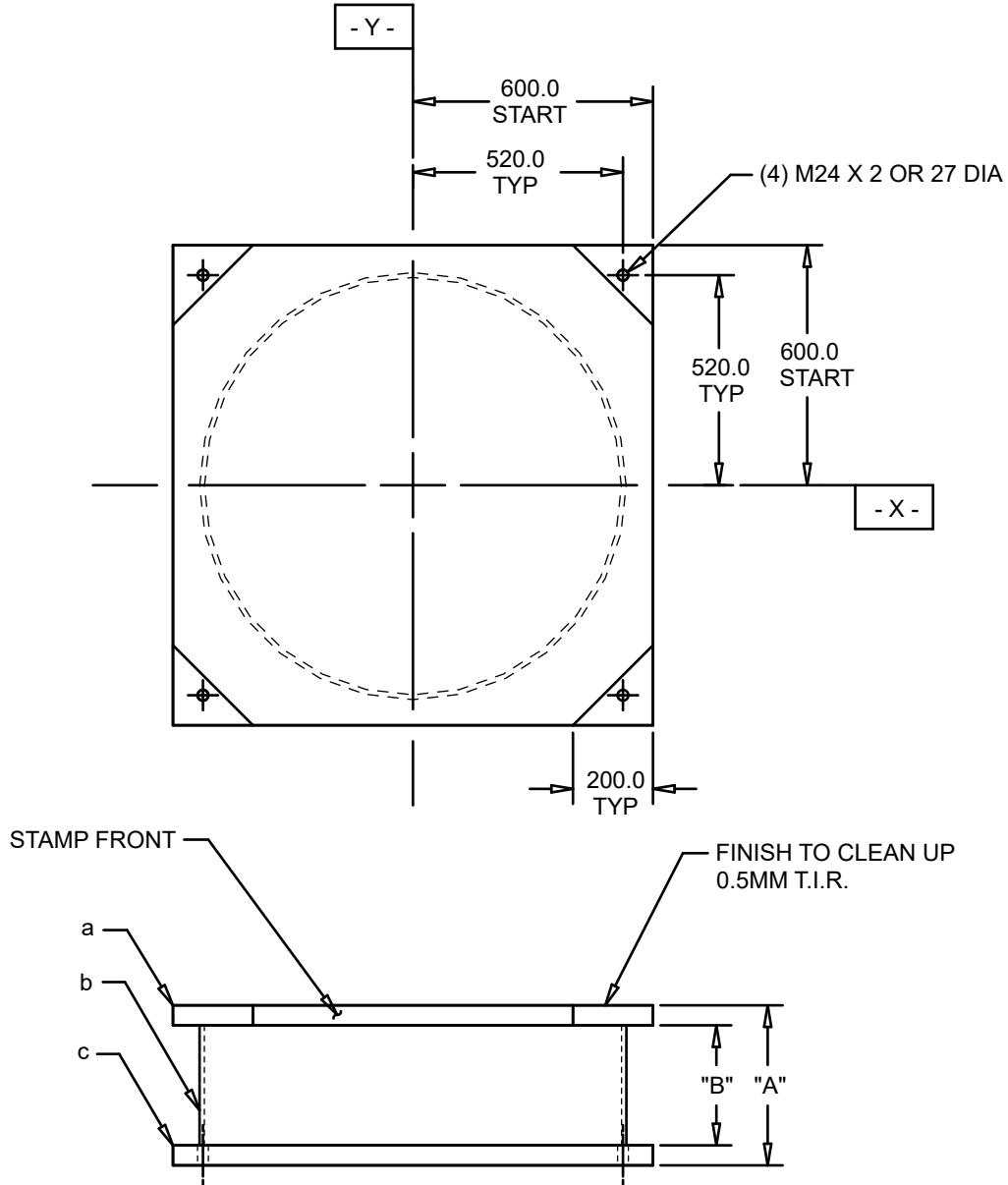

INCH

- a 2 - STL PLT ASTM A-36 - 2" X 1200MM X 1200MM
- b 1 - STL TBG ASTM A-36 - 42" OD X 1/2" W/T X "B"

METRIC

- a 2 - STL PLT ASTM A-36 - 50MM X 1200MM X 1200MM
- b 1 - STL TBG ASTM A-36 - 1067MM OD X 12MM W/T X "B"

TEST LOADS

- Fv = 54,100 N
- Fh = 25,700 N
- Mv = 117,000 Nm
- Mh = 68,500 Nm

STRESS < 62 MPa (9,000 psi)
 DEFLECTION < 0.5MM

SEE PAGE B-1.1 FOR GLOBAL MATERIALS CHART

ROBOT RISER

400kg / 500kg

GLOBAL STANDARD COMPONENTS



Assembly

02/13/08

NAAMS CODE	A +/- 3	B REF	HOLE DATA	MOUNTING SYSTEM #	WEIGHT kg
ARR220	200	98.4	M24 X 2	6	1140
ARR221	200	98.4	27.0 DIA	6	1173
ARR230	300	198.4	M24 X 2	6	1206
ARR231	300	198.4	27.0 DIA	6	1239
ARR240	400	298.4	M24 X 2	6	1272
ARR241	400	298.4	27.0 DIA	6	1305
ARR250	500	398.4	M24 X 2	6	1338
ARR251	500	398.4	27.0 DIA	6	1371
ARR260	600	498.4	M24 X 2	6	1404
ARR261	600	498.4	27.0 DIA	6	1437
ARR270	700	598.4	M24 X 2	6	1470
ARR271	700	598.4	27.0 DIA	6	1503
ARR280	800	698.4	M24 X 2	6	1536
ARR281	800	698.4	27.0 DIA	6	1569
ARR290	900	798.4	M24 X 2	6	1602
ARR291	900	798.4	27.0 DIA	6	1635
ARR300	1000	898.4	M24 X 2	6	1668
ARR301	1000	898.4	27.0 DIA	6	1701
ARR310	1100	998.4	M24 X 2	6	1734
ARR311	1100	998.4	27.0 DIA	6	1767
ARR320	1200	1098.4	M24 X 2	6	1800
ARR321	1200	1098.4	27.0 DIA	6	1833
ARR330	1300	1198.4	M24 X 2	6	1866
ARR331	1300	1198.4	27.0 DIA	6	1899
ARR340	1400	1298.4	M24 X 2	6	1932
ARR341	1400	1298.4	27.0 DIA	6	1965
ARR350	1500	1398.4	M24 X 2	6	1998
ARR351	1500	1398.4	27.0 DIA	6	2031
ARR360	1600	1498.4	M24 X 2	6	2064
ARR361	1600	1498.4	27.0 DIA	6	2097
ARR370	1700	1598.4	M24 X 2	6	2130
ARR371	1700	1598.4	27.0 DIA	6	2163
ARR380	1800	1698.4	M24 X 2	6	2196
ARR381	1800	1698.4	27.0 DIA	6	2229

SEE DRAWING ON PRECEDING PAGE

ROBOT RISER

600 kg

ATTACHING HOLES PER
 ROBOT MANUFACTURERS
 SPECIFICATION

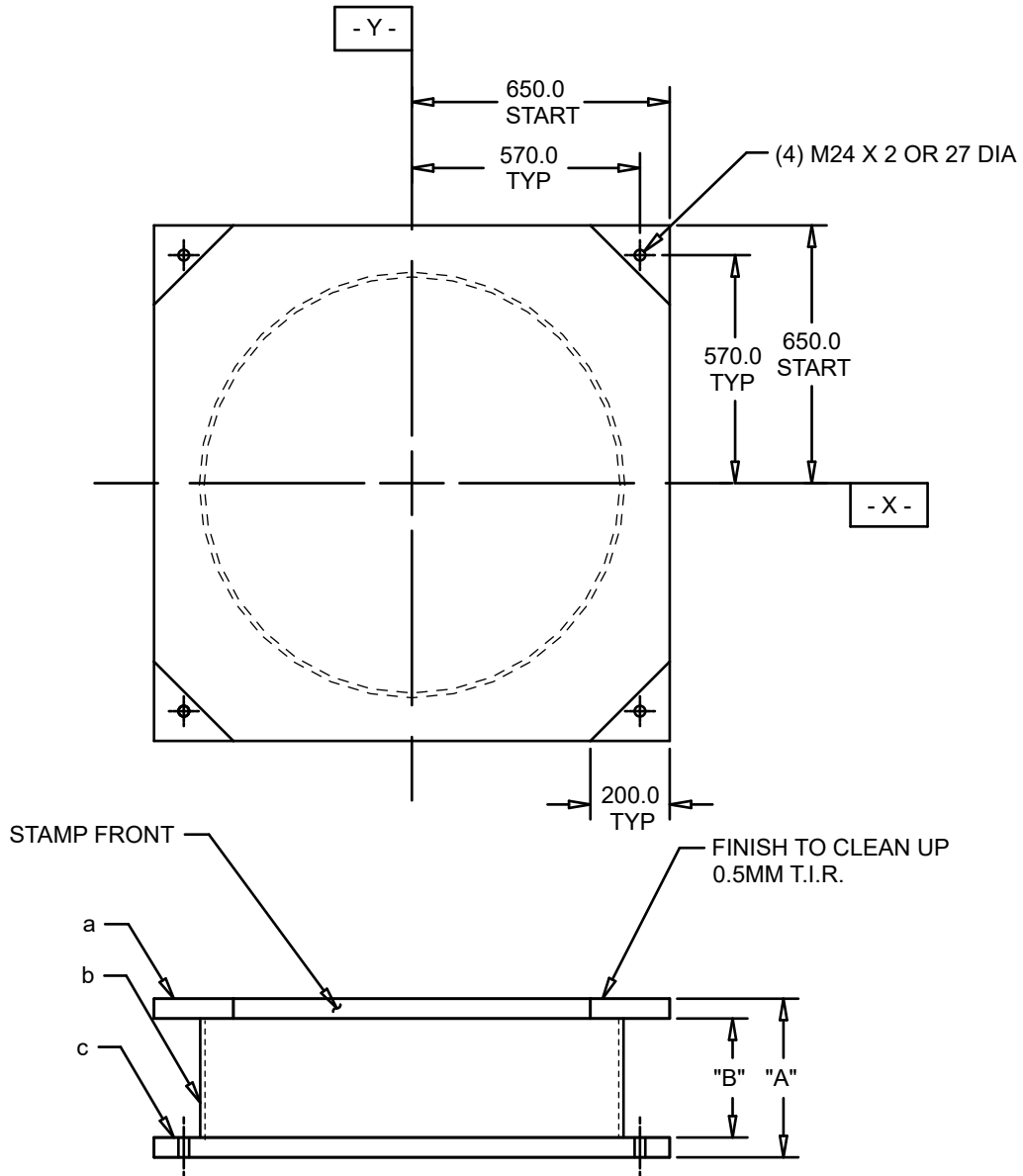

INCH

- a 2 - STL PLT ASTM A-36 - 2" X 1300MM X 1300MM
- b 1 - STL TBG ASTM A-36 - 42" OD X 1" W/T X "B"

METRIC

- a 2 - STL PLT ASTM A-36 - 50MM X 1300MM X 1300MM
- b 1 - STL TBG ASTM A-36 - 1067MM OD X 25MM W/T X "B"

TEST LOADS

- Fv = 36,700 N
- Fh = 35,280 N
- Mv = 116,620 Nm
- Mh = 29,400 Nm

SEE PAGE B-1.1 FOR GLOBAL MATERIALS CHART

STRESS < 62MPa (9,000 psi)
 DEFLECTION < 0.5 mm

ROBOT RISER

600 kg

NAAMS CODE	A +/- 3	B REF	HOLE DATA	MOUNTING SYSTEM #	WEIGHT kg
ARR420	200	98.4	M24 X 2	6	1369
ARR421	200	98.4	27.0 DIA	6	1434
ARR430	300	198.4	M24 X 2	6	1499
ARR431	300	198.4	27.0 DIA	6	1564
ARR440	400	298.4	M24 X 2	6	1629
ARR441	400	298.4	27.0 DIA	6	1694
ARR450	500	398.4	M24 X 2	6	1759
ARR451	500	398.4	27.0 DIA	6	1824
ARR460	600	498.4	M24 X 2	6	1889
ARR461	600	498.4	27.0 DIA	6	1954
ARR470	700	598.4	M24 X 2	6	2019
ARR471	700	598.4	27.0 DIA	6	2084
ARR480	800	698.4	M24 X 2	6	2149
ARR481	800	698.4	27.0 DIA	6	2214
ARR490	900	798.4	M24 X 2	6	2279
ARR491	900	798.4	27.0 DIA	6	2344
ARR500	1000	898.4	M24 X 2	6	2409
ARR501	1000	898.4	27.0 DIA	6	2474
ARR510	1100	998.4	M24 X 2	6	2539
ARR511	1100	998.4	27.0 DIA	6	2604
ARR520	1200	1098.4	M24 X 2	6	2669
ARR521	1200	1098.4	27.0 DIA	6	2734
ARR530	1300	1198.4	M24 X 2	6	2799
ARR531	1300	1198.4	27.0 DIA	6	2864
ARR540	1400	1298.4	M24 X 2	6	2929
ARR541	1400	1298.4	27.0 DIA	6	2994
ARR550	1500	1398.4	M24 X 2	6	3059
ARR551	1500	1398.4	27.0 DIA	6	3124
ARR560	1600	1498.4	M24 X 2	6	3189
ARR561	1600	1498.4	27.0 DIA	6	3254
ARR570	1700	1598.4	M24 X 2	6	3319
ARR571	1700	1598.4	27.0 DIA	6	3384
ARR580	1800	1698.4	M24 X 2	6	3449
ARR581	1800	1698.4	27.0 DIA	6	3514

SEE DRAWING ON PRECEDING PAGE

ROBOT RISER

700 kg

ATTACHING HOLES PER
 ROBOT MANUFACTURERS
 SPECIFICATION

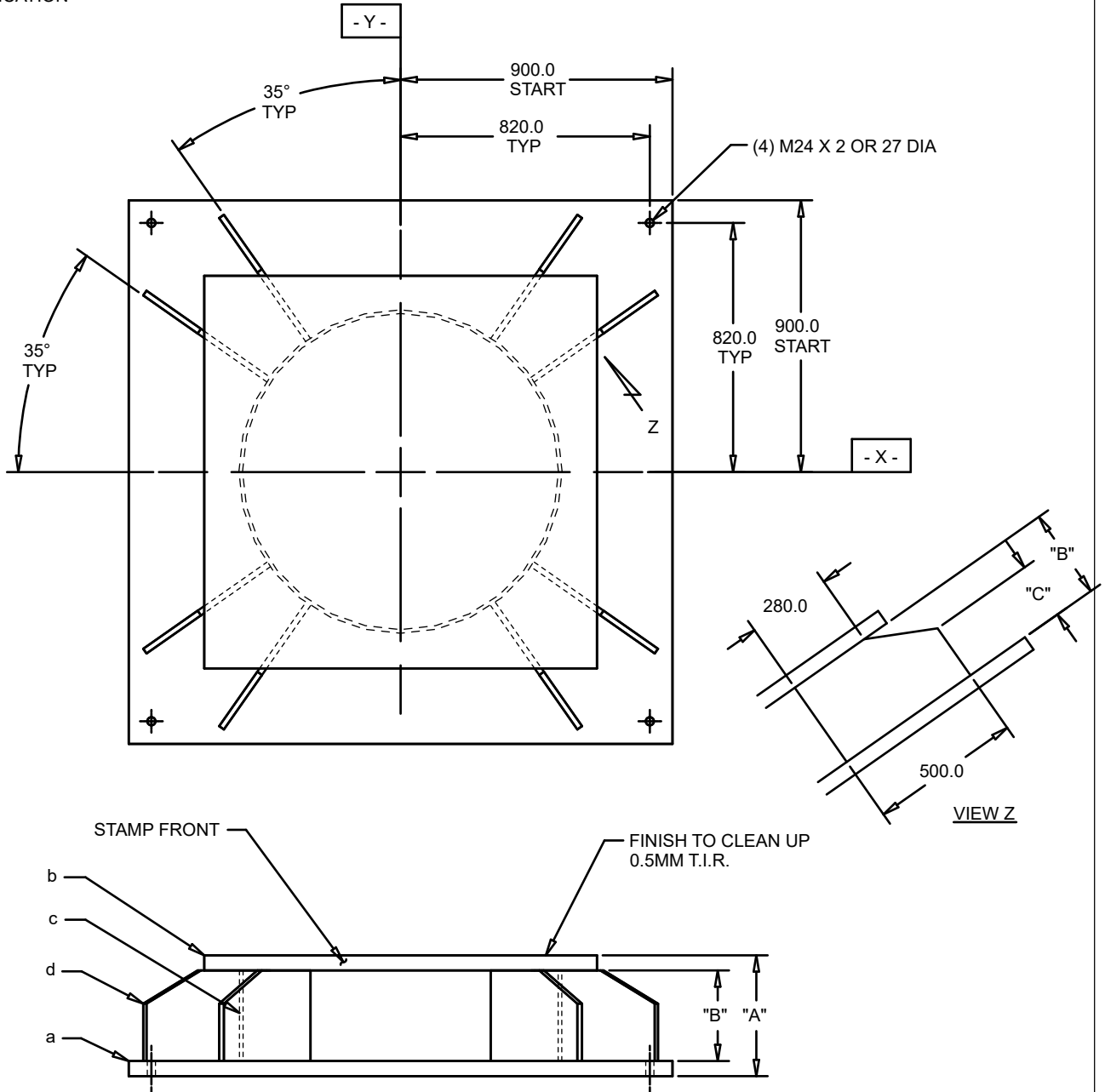

INCH

- a 1 - STL PLT ASTM A-36 - 2" X 1800MM X 1800MM
- b 1 - STL PLT ASTM A-36 - 2" X 1300MM X 1300MM
- c 1 - STL TBG ASTM A-36 - 42" OD X 1" W/T X "B"
- d 8 - STL PLT ASTM A-36 - 3/4" X 500MM X "B"

METRIC

- a 1 - STL PLT ASTM A-36 - 50MM X 1800MM X 1800MM
- b 1 - STL PLT ASTM A-36 - 50MM X 1300MM X 1300MM
- c 1 - STL TBG ASTM A-36 - 1067MM OD X 25MM W/T X "B"
- d 8 - STL PLT ASTM A-36 - 19MM X 500MM X "B"

SEE PAGE B-1.1 FOR GLOBAL MATERIALS CHART

TEST LOADS

- Fv = 97,500 N
- Fh = 36,100 N
- Mv = 236,000 Nm
- Mh = 133,000 Nm

STRESS < 62MPa (9,000 psi)
 DEFLECTION < 0.5MM

ROBOT RISER

700 kg

NAAMS CODE	A +/- 3	B REF	C REF	HOLE DATA	MOUNTING SYSTEM #	WEIGHT kg
ARR620	400	298.4	190	M24 X 2	6	2312
ARR621	400	298.4	190	27.0 DIA	6	2312
ARR630	500	398.4	250	M24 X 2	6	2431
ARR631	500	398.4	250	27.0 DIA	6	2431
ARR640	600	498.4	310	M24 X 2	6	2551
ARR641	600	498.4	310	27.0 DIA	6	2551
ARR650	700	598.4	370	M24 X 2	6	2671
ARR651	700	598.4	370	27.0 DIA	6	2671
ARR660	800	698.4	430	M24 X 2	6	2791
ARR661	800	698.4	430	27.0 DIA	6	2791
ARR670	900	798.4	490	M24 X 2	6	2911
ARR671	900	798.4	490	27.0 DIA	6	2911
ARR680	1000	898.4	550	M24 X 2	6	3031
ARR681	1000	898.4	550	27.0 DIA	6	3031
ARR690	1100	998.4	610	M24 X 2	6	3151
ARR691	1100	998.4	610	27.0 DIA	6	3151
ARR700	1200	1098.4	670	M24 X 2	6	3271
ARR701	1200	1098.4	670	27.0 DIA	6	3271
ARR710	1300	1198.4	730	M24 X 2	6	3391
ARR711	1300	1198.4	730	27.0 DIA	6	3391
ARR720	1400	1298.4	790	M24 X 2	6	3511
ARR721	1400	1298.4	790	27.0 DIA	6	3511
ARR730	1500	1398.4	850	M24 X 2	6	3631
ARR731	1500	1398.4	850	27.0 DIA	6	3631
ARR740	1600	1498.4	910	M24 X 2	6	3751
ARR741	1600	1498.4	910	27.0 DIA	6	3751
ARR750	1700	1598.4	970	M24 X 2	6	3871
ARR751	1700	1598.4	970	27.0 DIA	6	3871
ARR760	1800	1698.4	1030	M24 X 2	6	3991
ARR761	1800	1698.4	1030	27.0 DIA	6	3991

SEE DRAWING ON PRECEDING PAGE

ROBOT RISER CLIP (700 kg)

ABL444

A

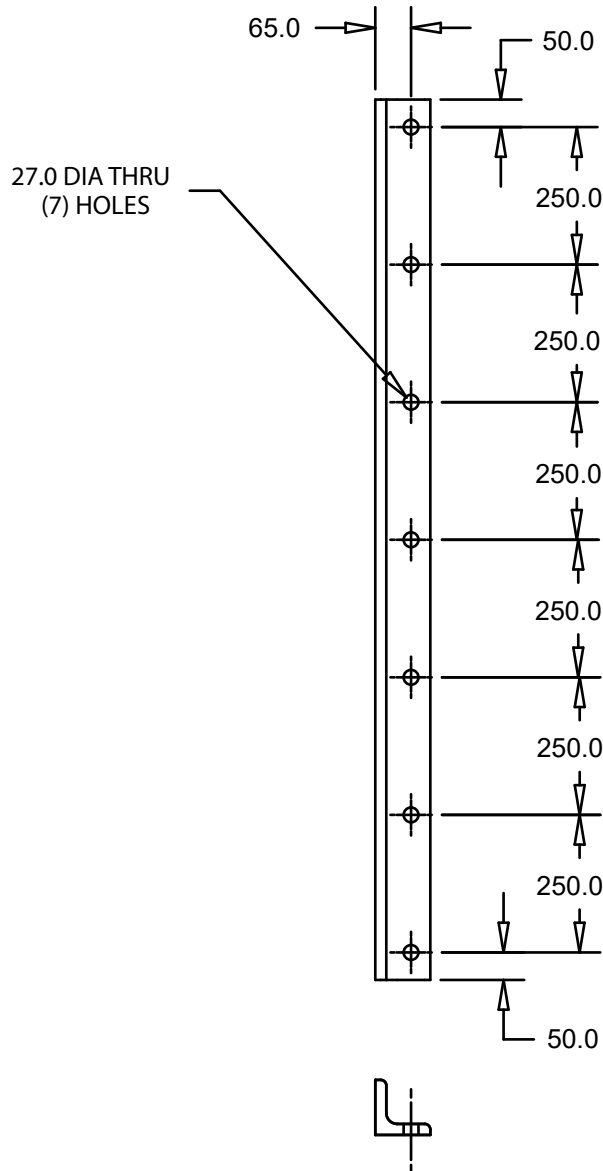

INCH

STLANG ASTM A-36 - 4" X 4" X 3/4" X 1600mm

WEIGHT = 43.9kg

METRIC

STLANG ASTM A-36 - 100 X 100 X 20 X 1600

WEIGHT = 47.2kg

SEE PAGE B-1.1 FOR GLOBAL MATERIALS CHART

ROBOT RISER

R2000iC 165F/210F/125L

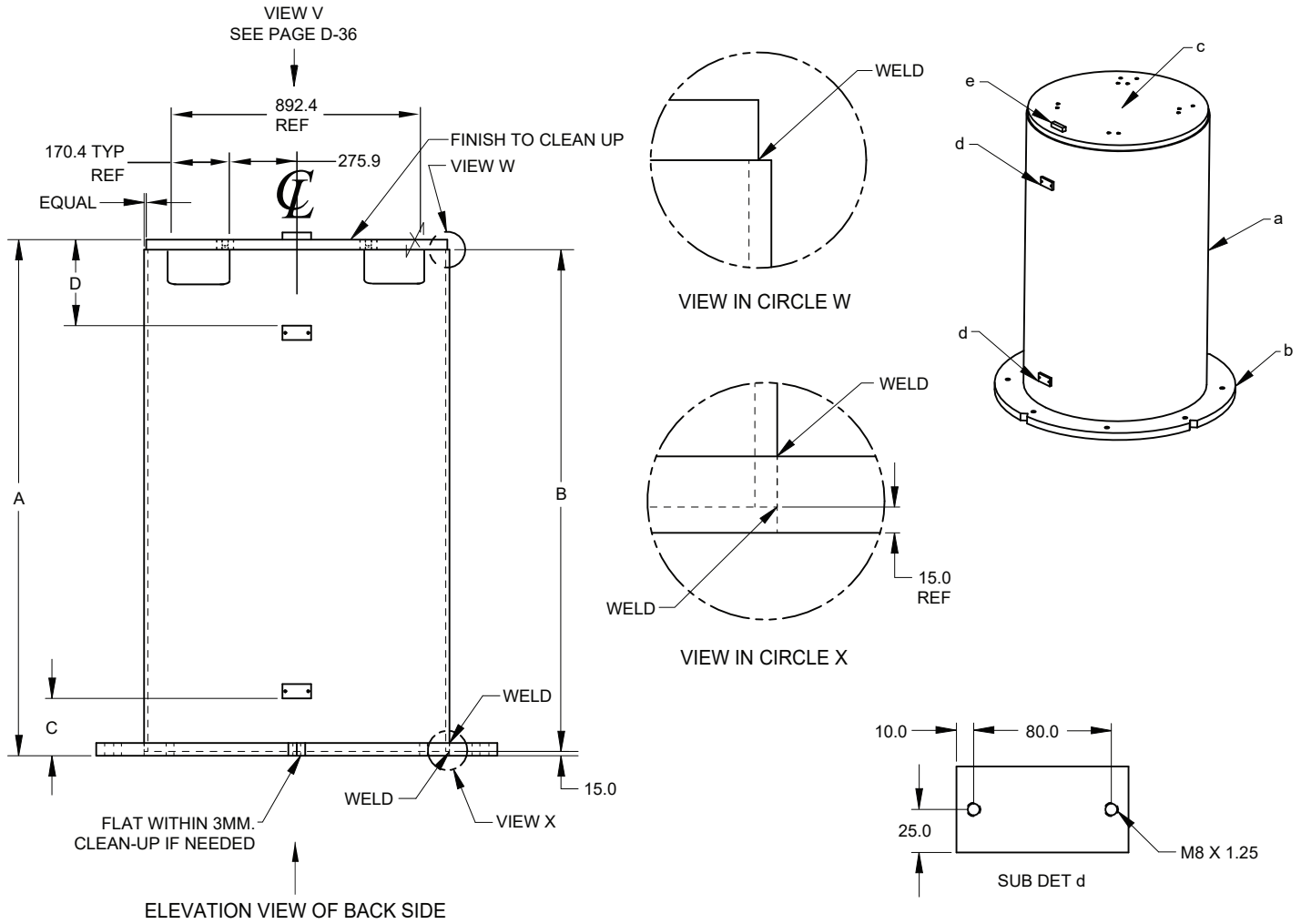

FEA WAS DONE WITH MAX LOADING: Mv 73.50 kNm

THE CONCRETE USED IN THE FEA AND HILTI PROFIS WAS A MINIMUM OF 6" DEEP SINGLE SLAB WITH A COMPRESSIVE STRENGTH OF 4000 PSI WITH 3/4" DIAMETER HILTI HIT-Z AND HAS-E ANCHORS.

NAAMS CODE	A ±5.0	B	C	D	WEIGHT
ARR820	300	245.0	N/A	N/A	567 kg
ARR830	600	545.0	300MM	N/A	667 kg
ARR840	900	845.0	450MM	N/A	765 kg
ARR850	1200	1145.0	200MM	300MM	864 kg
ARR860	1500	1445.0	200MM	300MM	963 kg
ARR870	1800	1745.0	200MM	300MM	1062 kg

SEE DRAWING ON NEXT PAGE

- INCH STOCK:
- (a) 1 ~ 1065MM DIA X 1/2" W/T x B - ASTM A36
 - (b) 1 ~ 1 3/4" X 1400MM DIA - ASTM A36
 - (c) 1 ~ 1 3/4" X 1050MM DIA - ASTM A36 MADE FROM HOLE IN SUB DET "b"
 - (d) 0, 1 or 2 ~ 1/2" X 2" X 100MM - ASTM A36 SEE CHART
 - (e) 1 ~ 1" X 1" X 50MM - ASTM A36

A

ROBOT RISER R2000iC 165F/210F/125L

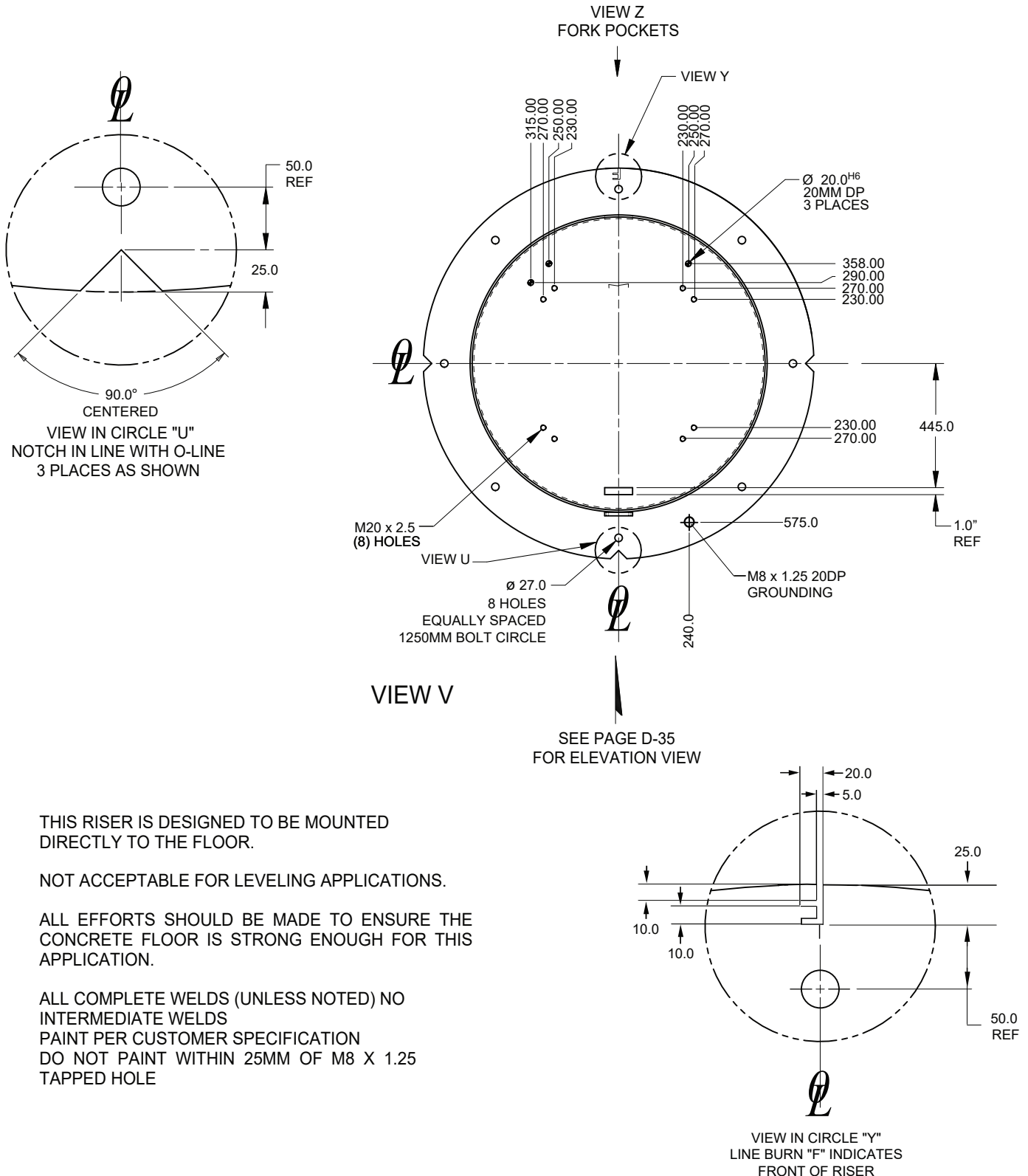

A

THIS RISER IS DESIGNED TO BE MOUNTED DIRECTLY TO THE FLOOR.

NOT ACCEPTABLE FOR LEVELING APPLICATIONS.

ALL EFFORTS SHOULD BE MADE TO ENSURE THE CONCRETE FLOOR IS STRONG ENOUGH FOR THIS APPLICATION.

ALL COMPLETE WELDS (UNLESS NOTED) NO INTERMEDIATE WELDS
PAINT PER CUSTOMER SPECIFICATION
DO NOT PAINT WITHIN 25MM OF M8 X 1.25 TAPPED HOLE

SEE DRAWING ON PRECEDING PAGE

ROBOT RISER R2000iC 165F/210F/125L

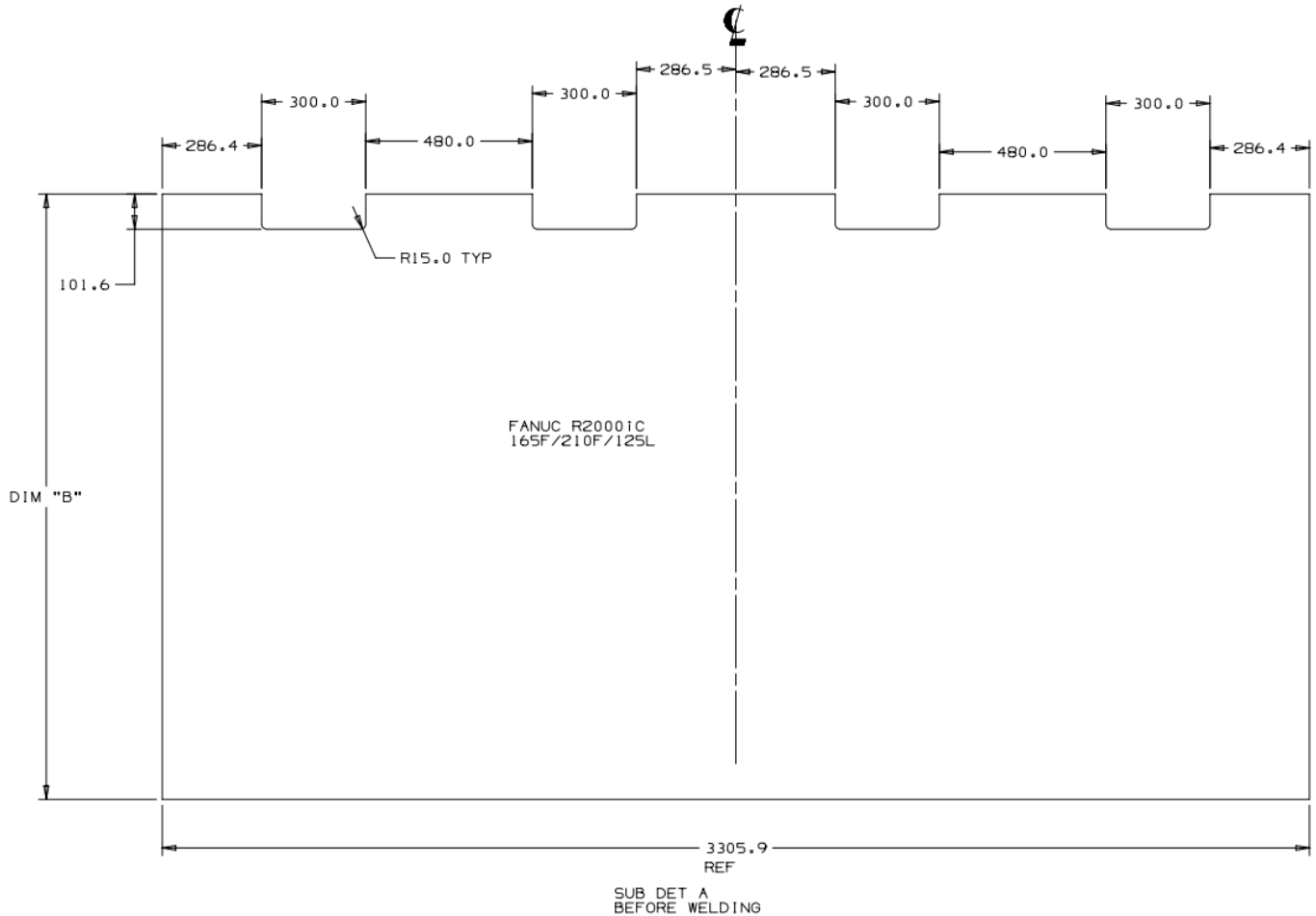

FORK POCKETS TO BE ADDED TO THE TUBE BEFORE WELD

ROBOT RISER

M900iA 260L/350 & M900iB/280L/360/330L

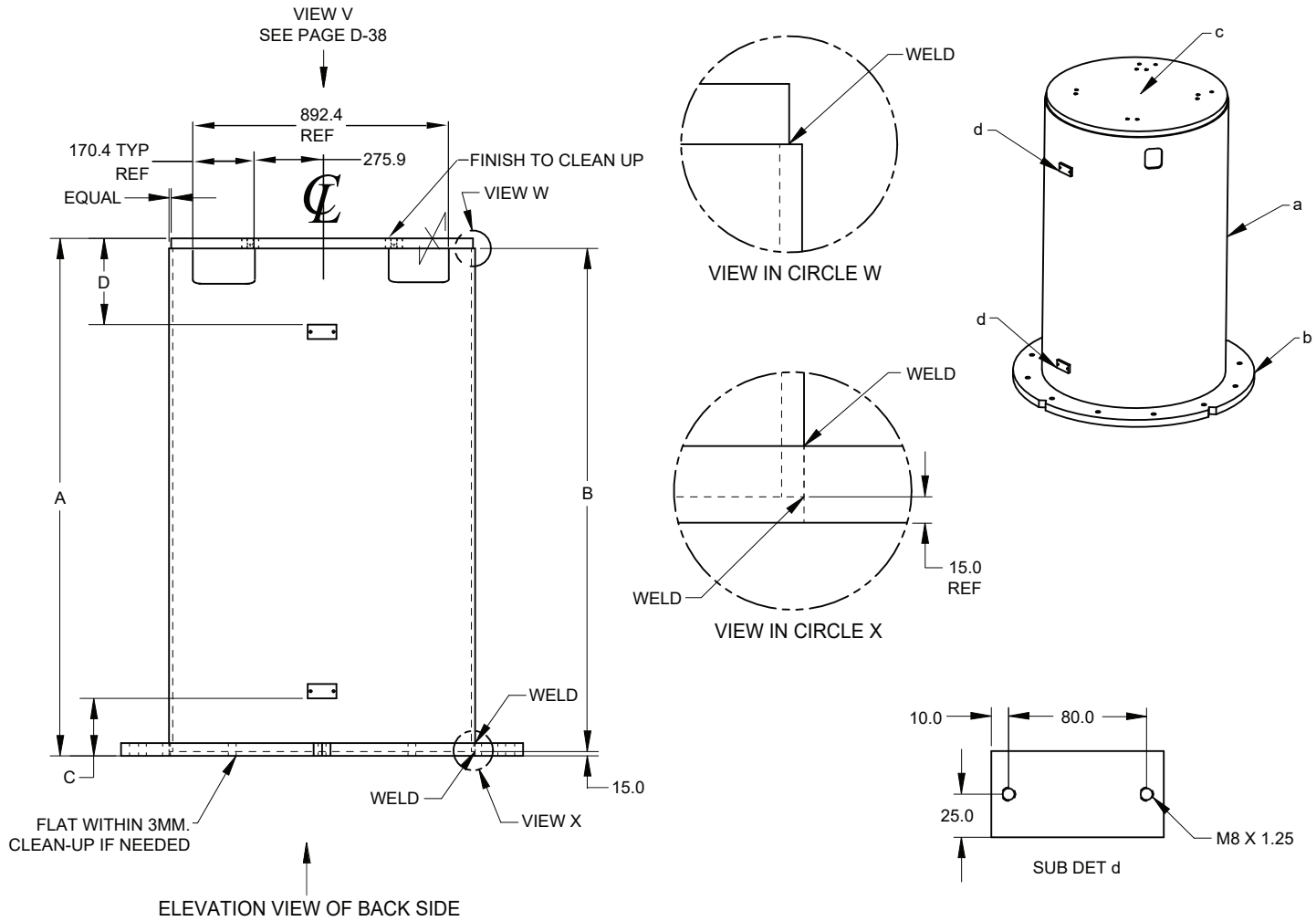

FEA WAS DONE WITH MAX LOADING: Mv 119.56 kNm

THE CONCRETE USED IN THE FEA AND HILTI PROFIS WAS A MINIMUM OF 6" DEEP SINGLE SLAB WITH A COMPRESSIVE STRENGTH OF 4000 PSI WITH HILTI HIT-Z AND HAS-E ANCHORS.

NAAMS CODE	A ±5.0	B	C	D	WEIGHT
ARR920	300	245.0	N/A	N/A	566kg
ARR930	600	545.0	300MM	N/A	666kg
ARR940	900	845.0	450MM	N/A	765kg
ARR950	1200	1145.0	200MM	300MM	863kg
ARR960	1500	1445.0	200MM	300MM	962kg
ARR970	1800	1745.0	200MM	300MM	1061kg

SEE DRAWING ON NEXT PAGE

- INCH STOCK:
- (a) 1 ~ 1065MM DIA X 1/2" W/T x B - ASTM A36
 - (b) 1 ~ 1 3/4" X 1400MM DIA - ASTM A36
 - (c) 1 ~ 1 3/4" X 1050MM DIA - ASTM A36 MADE FROM HOLE IN SUB DET "b"
 - (d) 0, 1 or 2 ~ 1/2" X 2" X 100MM - ASTM A36 SEE CHART

A

ROBOT RISER

M900iA 260L/350 & M900iB/280L/360/330L

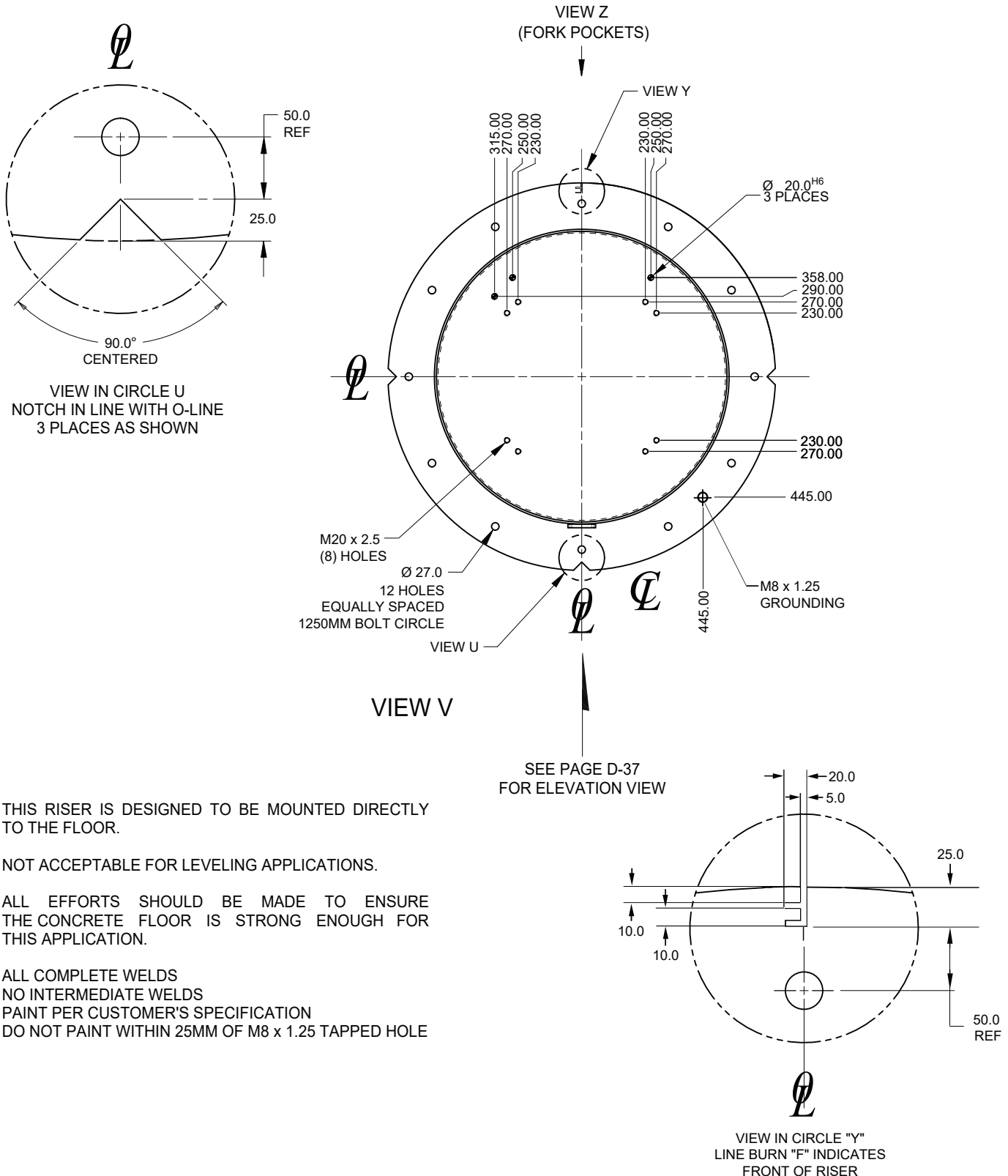

A

THIS RISER IS DESIGNED TO BE MOUNTED DIRECTLY TO THE FLOOR.

NOT ACCEPTABLE FOR LEVELING APPLICATIONS.

ALL EFFORTS SHOULD BE MADE TO ENSURE THE CONCRETE FLOOR IS STRONG ENOUGH FOR THIS APPLICATION.

ALL COMPLETE WELDS
NO INTERMEDIATE WELDS
PAINT PER CUSTOMER'S SPECIFICATION
DO NOT PAINT WITHIN 25MM OF M8 x 1.25 TAPPED HOLE

SEE DRAWING ON PRECEDING PAGE

ROBOT RISER

M900iA 260L/350 & M900iB/280L/360/330L

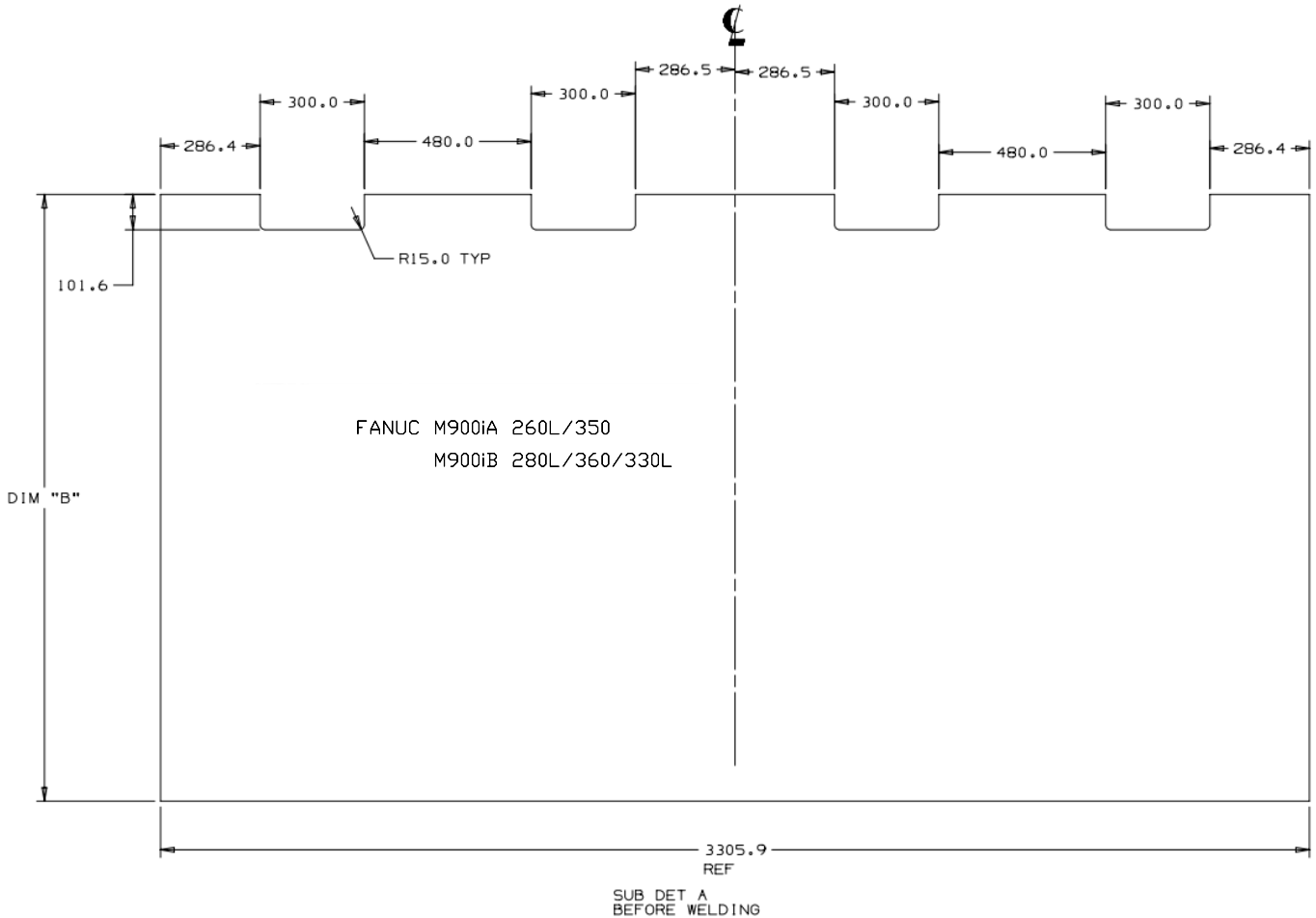

FORK POCKETS TO BE ADDED TO THE TUBE BEFORE WELD